



PLANNING AND INSTALLATION GUIDE

PMP-PTP 450 Series

Release 24.2.2



Reservation of Rights

Cambium reserves the right to make changes to any products described herein to improve reliability, function, or design, and reserves the right to revise this document and to make changes from time to time in content hereof with no obligation to notify any person of revisions or changes. Cambium recommends reviewing the Cambium Networks website for the latest changes and updates to products. Cambium does not assume any liability arising out of the application or use of any product, software, or circuit described herein; neither does it convey license under its patent rights or the rights of others. It is possible that this publication may contain references to, or information about Cambium products (machines and programs), programming, or services that are not announced in your country. Such references or information must not be construed to mean that Cambium intends to announce such Cambium products, programming, or services in your country.

Copyrights

This document, Cambium products, and 3rd Party software products described in this document may include or describe copyrighted Cambium and other 3rd Party supplied computer programs stored in semiconductor memories or other media. Laws in the United States and other countries preserve for Cambium, its licensors, and other 3rd Party supplied software certain exclusive rights for copyrighted material, including the exclusive right to copy, reproduce in any form, distribute and make derivative works of the copyrighted material. Accordingly, any copyrighted material of Cambium, its licensors, or the 3rd Party software supplied material contained in the Cambium products described in this document may not be copied, reproduced, reverse engineered, distributed, merged or modified in any manner without the express written permission of Cambium. Furthermore, the purchase of Cambium products shall not be deemed to grant either directly or by implication, estoppel, or otherwise, any license under the copyrights, patents or patent applications of Cambium or other 3rd Party supplied software, except for the normal non-exclusive, royalty free license to use that arises by operation of law in the sale of a product.

Restrictions

Software and documentation are copyrighted materials. Making unauthorized copies is prohibited by law. No part of the software or documentation may be reproduced, transmitted, transcribed, stored in a retrieval system, or translated into any language or computer language, in any form or by any means, without prior written permission of Cambium.

License Agreements

The software described in this document is the property of Cambium and its licensors. It is furnished by express license agreement only and may be used only in accordance with the terms of such an agreement.

High Risk Materials

Cambium and its supplier(s) specifically disclaim any express or implied warranty of fitness for any high-risk activities or uses of its products including, but not limited to, the operation of nuclear facilities, aircraft navigation or aircraft communication systems, air traffic control, life support, or weapons systems ("High Risk Use").

This product is not restricted in the EU. Any High Risk is unauthorized, is made at your own risk and you shall be responsible for any and all losses, damage or claims arising out of any High-Risk Use.

Contents

Contents	3
About This User Guide	13
Purpose	13
Product notation conventions in document	13
Cross references	15
Feedback	16
Important regulatory information	16
Application software	16
USA specific information	16
Canada specific information	17
Renseignements spécifiques au Canada	18
EU Declaration of Conformity	19
Specific expertise and training for professional installers	19
Ethernet networking skills	19
Lightning protection	19
Problems and warranty	20
Reporting problems	20
Repair and service	20
Hardware warranty	20
Security advice	20
Warnings, cautions, and notes	21
Warnings	21
Cautions	21
Notes	21
Caring for the environment	21
In EU countries	22

In non-EU countries	22
Operational restrictions for 6 GHz U-NII devices	22
Chapter 1: Product Description	24
Overview of the 450 Platform Family	24
Purpose	24
450 Platform Family	24
Wireless operation	46
Time Division Duplexing	46
Encryption	49
MIMO	49
MU-MIMO	50
System management	51
Management agent	51
Web server	51
Remote Authentication Dial-in User Service (RADIUS)	53
Network Time Protocol (NTP)	54
cnMaestro™	54
Radio recovery mode	55
Chapter 2: System hardware	57
System components	58
PMP	58
Backhaul (PTP)	62
450 Platform family ODU interfaces	66
PMP 450m Series interfaces AP – 3 GHz	66
PMP 450m Series interfaces AP - 5 GHz	67
PMP/PTP 450b/450b6 High Gain Series Interfaces - SM/BHS	68
PMP/PTP 450b Mid-Gain Series interfaces - SM/BH	70
PMP/PTP 450b/450b6 High Gain Series Interfaces - SM/BHS	71

PMP/PTP 450b Retro SM/BH interfaces	72
PMP/PTP 450b Connectorized Interfaces - SM/BH	73
PMP/PTP 450 Series interfaces - AP	74
PMP/PTP 450 Series interfaces – SM/BH	76
PMP 450 MicroPoP Series (Omni, Sector and Connectorized) interfaces - AP	79
450v Series interfaces AP – 5/6 GHz	83
450v Series interfaces SM/BHM/BHS (4x4) – 5/6 GHz	85
450v Series interfaces SM/BHM/BHS (2x2) – 5/6 GHz	86
ATEX/HAZLOC variants	87
Diagnostic LEDs	87
Power supply options	104
Power supply – PMP 450m Series	106
Power supply – PMP/PTP 450i Series	106
Power supply – PMP/PTP 450b Series	110
Power supply – 450v Series	111
Power supply – PMP/PTP 450 Series	114
Power supply – PMP 450 MicroPoP series	116
ODU mounting brackets and accessories	117
Lightning protection	118
MicroPoP lightning arrester details	120
Cabling	123
450b/450v Audio jack AUX Port synchronization cables	123
Ethernet standards and cable lengths	124
Outdoor copper Cat5e Ethernet cable	125
SFP module kits	126
PoE Cable Pinout	126
Ethernet cable testing	131
Lightning protection unit (LPU) and grounding kit	132

DC LPU and grounding kit	134
Cable grounding kit	136
Antennas and antenna cabling	136
Antenna requirements	136
Supported AP external antennas	137
Supported external BH/SM antenna	137
RF cable and connectors	137
Antenna accessories	138
GPS synchronization	138
Universal GPS (UGPS)	138
Cluster Management Module (CMM5)	139
CMM5 Controller module	141
CMM5 injector module	142
CMM5 injector compatibility matrix	142
CMM5 specifications	143
CMM4/CMM5 (Rack mount)	144
CMM4/CMM5 (Cabinet with switch)	146
CMM4/CMM5 (Cabinet without switch)	146
CMM3/CMMmicro	147
GPS Synchronisation for PMP 450b6	148
Installing a GPS receiver	149
GPS receiver location	149
Mounting the GPS receiver	150
Cabling the GPS Antenna	151
Installing and connecting the GPS LPU	151
Installing GPS Module for PMP 450b6	151
Ordering the components	154
Chapter 3: System Planning	169

Typical deployment	169
ODU with PoE interface to PSU	169
Site planning	174
Site selection for PMP/PTP radios	174
Power supply site selection	175
Maximum cable lengths	175
Grounding and lightning protection	175
ODU and external antenna location	177
ODU ambient temperature limits	177
ODU wind loading	178
Hazardous locations	182
Drop cable grounding points	182
Lightning Protection Unit (LPU) location	183
Radio Frequency planning	183
Regulatory limits	183
Available spectrum	183
Analyzing the RF Environment	184
Channel bandwidth selection	184
Anticipating reflection of radio waves	184
Obstructions in the Fresnel zone	185
Planning for co-location	185
Multiple OFDM AP Clusters	198
Considerations on back-to-back frequency reuse	199
Link planning	205
Range and obstacles	205
Path loss	206
Calculating Link Loss	207
Calculating Rx Signal Level	207

Calculating fade margin	208
Adaptive modulation	208
Planning for connectorized units	209
When to install connectorized units	209
Choosing external antennas	209
Calculating RF cable length (5.8 GHz FCC only)	209
Data network planning	210
Understanding addresses	210
Dynamic or static addressing	210
DNS Client	211
Network Address Translation (NAT)	212
Developing an IP addressing scheme	213
Address Resolution Protocol (ARP)	213
Allocating subnets	213
Selecting non-routable IP addresses	214
Translation bridging	214
Engineering VLANs	215
Network management planning	218
Planning for Simple Network Management Protocol (SNMP) operation	218
Enabling SNMP	220
Security planning	220
Isolating AP/BHM from the Internet	220
Encrypting radio transmissions	220
Planning for HTTPS operation	221
Planning for SNMPv3 operation	221
Managing module access by passwords	222
Planning for RADIUS operation	223
Filtering protocols and ports	224

Encrypting downlink broadcasts	227
Isolating SMs in PMP	228
Filtering management through Ethernet	228
Allowing management from only specified IP addresses	228
Configuring management IP by DHCP	229
Controlling PPPoE PADI Downlink Forwarding	229
Remote AP deployment	229
Remote AP (RAP) Performance	231
Example use case for RF obstructions	231
Example use case for passing sync	232
Physical connections involving the remote AP	233
Passing Sync signal	234
Wiring to extend network sync	237
Chapter 4: Preparing for installation	239
Safety	239
Hazardous locations	239
Siting of ODU and soundness of structure	239
Working at heights and near power lines	239
Power supply and power safety	239
External cables	240
RF exposure near the antenna	240
Grounding and lightning protection requirements	240
Grounding and protective earth	241
Thermal Safety	241
Preparing for installation	242
ODU pre-configuration	242
Preparing personnel	242
Preparing inventory	242

Preparing tools	243
Testing system components	243
Unpacking Components	243
Preparing the ODU	243
Configuring Link for Test	251
Configuring the management PC	251
Logging into the web interface – AP/SM/BH	252
Using the Quick Start Configuration Wizard of the AP/BHM	253
Chapter 5: Installation	254
ODU variants and mounting bracket options	254
Mount the ODU, LPU and surge suppressor	255
Attach ground cables to the ODU	255
Mount the ODU on the mast	258
Mount the top LPU	300
Mount the Surge Suppressor	300
General protection installation	304
Installing the copper Cat5e Ethernet interface	310
Install the main drop cable	311
Install the bottom LPU to PSU drop cable	312
Installing external antennas to a connectorized ODU	314
PMP 450i Series	314
PMP 450 Series	323
PMP 450i Series AP 900 MHz	332
PMP 450 Series SM 900 MHz	340
	345
Alignment of the 4x4 PMP 450v SM/BHS	345
Enable two carriers at the AP when aligning the SM	347
Installing an integrated ODU	349

PMP 450m Series – 5 GHz AP	349
PMP 450m Series – 3 GHz AP	351
PMP/PTP 450i Series – AP/SM/BH	354
Connecting Cat5e Ethernet cable	355
Connecting an RJ45 and gland to a unit	355
Disconnecting an RJ45 and gland from a unit	357
Installing ODU	357
Installing a 450 Platform Family AP	357
Installing a 450 Platform Family SM	358
Installing a 450 Platform Family BHM	360
Installing a 450 Platform Family BHS	360
Configuring the Link	361
Monitoring the Link	361
Installing the AC Power Injector	361
Installing CMM4, CMM5, and cnMatrix	362
Supplemental installation information	362
Stripping drop cable	363
Creating a drop cable grounding point	363
Attaching and weatherproofing an N type connector	366
Chapter 6: Compliance with safety standards	370
Electrical safety compliance	370
Electromagnetic compatibility (EMC) compliance	370
Human exposure to radio frequency energy	370
Power density exposure limit	371
Calculation of power density	371
Calculated distances and power compliance margins	372
Tx power limits for PMP 450 MicroPoP	384
Hazardous location compliance	384

ATEX	384
Chapter 7: Compliance with radio regulations	386
Type approvals	386
Brazil specific information	388
Brazil notification	388
Brazil certification numbers	388
Australia Notification	388
Regulatory Requirements for CEPT Member States (www.cept.org)	388
Canadian Installation Procedures (900 MHz 450i)	389

About This User Guide

This guide describes the planning and installation of Cambium Point-to-Point (PTP) and Point-to-Multipoint (PMP) wireless Ethernet bridges. It covers PMP/PTP 450, 450i, 450b, 450d, PMP 450m, and 450v platform series. It is intended for use by the system designer, system installer, and system administrator.

Purpose

Cambium's PMP/PTP 450 documents are intended to instruct and assist personnel in the operation, installation, and maintenance of Cambium PMP/PTP equipment and ancillary devices of the 450 Platform Family. It is recommended that all personnel engaged in such activities be properly trained.

Cambium Networks disclaims all liability whatsoever, implied or expressed, for any risk of damage, loss, or reduction in system performance arising directly or indirectly out of the failure of the customer, or anyone acting on the customer's behalf, to abide by the instructions, system parameters, or recommendations made in this document.

Product notation conventions in document

This document covers Cambium 450 Series, 450i Series, and 450m Series products. The following notation conventions are followed while referring to product family:

Product notation	Description
450 Platform Family	Refers to the complete 450 Series family, which includes 450 Series, 450i Series, 450b Series, and 450m Series
450 Series	Refers to 450 Series devices in the following configurations: PMP 450 <ul style="list-style-type: none">• AP [2.4GHz/3.5 GHz/3.65 GHz/5 GHz]<ul style="list-style-type: none">◦ Connectorized• SM [900 MHz/2.4GHz/3.5 GHz/3.65 GHz/5 GHz]<ul style="list-style-type: none">◦ Connectorized/Integrated PTP 450 <ul style="list-style-type: none">• BHM/BHS [900 MHz/3.5 GHz/3.65 GHz/5 GHz]<ul style="list-style-type: none">◦ Connectorized/Integrated PMP 450d <ul style="list-style-type: none">• SM [5 GHz] - Dish

Product notation	Description
450i Series	<p>Refers to 450i Series devices in the following configurations:</p> <p>PMP 450i</p> <ul style="list-style-type: none"> • AP [900 MHz/3 GHz/5 GHz] <ul style="list-style-type: none"> ◦ Connectorized/Integrated • SM [3 GHz/5 GHz] <ul style="list-style-type: none"> ◦ Connectorized/Integrated <p>PTP 450i</p> <ul style="list-style-type: none"> • BHM/BHS [3 GHz/5 GHz] <ul style="list-style-type: none"> ◦ Connectorized/Integrated
450b Series	<p>Refers to 450b Series devices in the following configurations:</p> <p>PMP/PTP 450b Mid-Gain</p> <ul style="list-style-type: none"> • SM [5 GHz] <ul style="list-style-type: none"> ◦ Integrated • BHM/BHS [5 GHz] <ul style="list-style-type: none"> ◦ Integrated <p>PMP/PTP 450b Connectorized</p> <ul style="list-style-type: none"> • SM [5 GHz] • BHM/BHS [5 GHz] <p>PMP/PTP 450b High Gain</p> <ul style="list-style-type: none"> • SM [3 GHz/5 GHz] - Dish • BHM/BHS [3 GHz/5 GHz] - Dish
450m Series	<p>Refers to 450m Series device configuration:</p> <p>PMP 450m</p> <ul style="list-style-type: none"> • AP 5 GHz <ul style="list-style-type: none"> ◦ Integrated

Product notation	Description
	<ul style="list-style-type: none"> • AP 3 GHz <ul style="list-style-type: none"> ◦ Integrated
450 MicroPoP Series	<p>Refers to 450 MicroPoP Series devices in the following configurations:</p> <ul style="list-style-type: none"> • PMP 450 MicroPop Omni AP 5 GHz <ul style="list-style-type: none"> ◦ Integrated • PMP 450 MicroPop Sector AP 5 GHz <ul style="list-style-type: none"> ◦ Integrated • PMP 450 MicroPop Connectorized AP 5 GHz <ul style="list-style-type: none"> ◦ Connectorized
450b Retro Series	<p>Refers to 450b Retro Series devices in the following configurations:</p> <ul style="list-style-type: none"> • PMP 450b Retro SM 5 GHz <ul style="list-style-type: none"> ◦ Integrated • PTP 450b BHM/BHS 5 GHz <ul style="list-style-type: none"> ◦ Integrated
450v	<p>Refers to 450v Series devices in the following configurations:</p> <ul style="list-style-type: none"> • AP 5/6 GHz (4x4) <ul style="list-style-type: none"> ◦ Integrated • SM 5/6 GHz (4x4) <ul style="list-style-type: none"> ◦ Integrated • SM 5/6 GHz (2x2) <ul style="list-style-type: none"> ◦ Integrated

Cross references

References to external publications are shown in italics. Other cross references, emphasized in blue text in electronic versions, are active links to the references.

This document is divided into numbered chapters that are divided into sections. Sections are not numbered but are individually named at the top of each page and are listed in the table of contents.

Feedback

We appreciate feedback from the users of our documents. This includes feedback on the structure, content, accuracy, or completeness of our documents. To provide feedback, visit our support website, <https://support.cambiumnetworks.com>.



Caution

This device complies with Part 15 of the FCC Rules. Operation is subject to the following two conditions:

- This device may not cause harmful interference, and
- This device must accept any interference received, including interference that may cause undesired operation

Important regulatory information

The 450 Platform Family products are certified as unlicensed device in frequency bands where it is not allowed to cause interference with licensed services (called primary users of the bands).

Application software

Download the latest 450 Platform Family software and install it in the Outdoor Units (ODUs) before deploying the equipment. Instructions for installing software are provided in later sections of this guide.

USA specific information

The USA Federal Communications Commission (FCC) requires manufacturers to implement special features to prevent interference to weather radar systems that operate in the band 5600 MHz to 5650 MHz. These features must be implemented in all products able to operate outdoors in the band 5470 MHz to 5725 MHz.

Manufacturers must ensure that such radio products cannot be configured to operate outside of FCC rules; specifically, it must not be possible to disable or modify the radar protection functions that have been demonstrated to the FCC.

Cambium Networks supplies variants of the 5 GHz 450, 450i, 450b, and 450m Series specifically for operation in the USA to comply with FCC requirements (KDB 905462 D02 UNII DFS Compliance Procedures New Rules v02). These variants are only allowed to operate with license keys that comply with FCC rules.

To ensure compliance when using PMP 450 Series and PTP 450 Series, follow the recommendation in [Important regulatory information](#).

External antennas

When using a connectorized version of the product, the conducted transmit power may need to be reduced to ensure that the regulatory limit on transmitter Effective Isotropic Radiated Power (EIRP) is not exceeded.

The installer must have an understanding of how to compute the effective antenna gain from the actual antenna gain and the feeder cable losses.

The range of permissible values for maximum antenna gain and feeder cable losses are included in this user guide together with a sample calculation. The product GUI automatically applies the correct conducted power limit to ensure that the installation can not exceed the EIRP limit when the appropriate values for antenna gain and feeder cable losses are entered into the GUI.

Avoidance of weather radars (USA only)

To comply with FCC rules (KDB 443999: Interim Plans to Approve UNII Devices Operating in the 5470 - 5725 MHz Band with Radar Detection and DFS Capabilities), units that are installed within 35 km (22 miles) of a Terminal Doppler Weather Radar (TDWR) system (or have a line of sight propagation path to such a system) must be configured to avoid any frequency within +30 MHz or -30 MHz of the frequency of the TDWR device. This requirement applies even if the master is outside the 35 km (22 miles) radius but communicates with outdoor clients which may be within the 35 km (22 miles) radius of the TDWRs. If interference is not eliminated, a distance limitation based on line-of-sight from TDWR needs to be used. Devices with bandwidths greater than 20 MHz may require greater frequency separation.

When planning a link in the USA, visit <http://spectrumbridge.com/udia/home.aspx>, enter the location of the planned link and search for TDWR radars. If a TDWR system is located within 35 km (22 miles) or has a line of sight propagation to the PTP device, perform the following tasks:

- Register the installation at <http://spectrumbridge.com/udia/home.aspx>.
- Make a list of channel center frequencies that must be barred, that is, those falling within +30 MHz or -30 MHz of the frequency of the TDWR radars.

The 450 Platform Family AP must be configured to not operate on the affected channels.

Canada specific information



Caution

This device complies with Innovation, Science And Economic Development Canada's (ISED) license-exempt RSSs. Operation is subject to the following two conditions:

1. This device may not cause interference, and
2. This device must accept any interference received, including interference that may cause undesired operation.

ISED requires manufacturers to implement special features to prevent interference to weather radar systems that operate in the band 5600 MHz to 5650 MHz. These features must be implemented in all products able to operate outdoors in the band 5470 MHz to 5725 MHz.

Manufacturers must ensure that such radio products cannot be configured to operate outside of ISED rules. Specifically, it must not be possible to disable or modify the radar protection functions that have been demonstrated to ISED.

To comply with these ISEDC requirements, Cambium Networks supplies variants of the 450 Platform Family for operation in Canada. These variants are only allowed to operate with license keys that comply with ISEDC rules. In particular, the operation of radio channels overlapping the band 5600 MHz to 5650 MHz is not allowed and these channels are permanently barred.

In addition, other channels may also need to be barred when operating close to weather radar installations.

Other variants of the 450 Platform Family are available for use in the rest of the world, but these variants are not supplied to Canada except under strict controls when they are needed for export and deployment outside Canada.

Renseignements spécifiques au Canada



Attention

Le présent appareil est conforme aux CNR d'Industrie Canada applicables aux appareils radio exempts de licence. L'exploitation est autorisée aux deux conditions suivantes :

- (1) l'appareil ne doit pas produire de brouillage, et
- (2) l'utilisateur de l'appareil doit accepter tout brouillage radioélectrique subi, même si le brouillage est susceptible d'en compromettre le fonctionnement.

ISEDC a demandé aux fabricants de mettre en œuvre des mécanismes spécifiques pour éviter d'interférer avec des systèmes radar fonctionnant dans la bande 5600 MHz à 5650 MHz. Ces mécanismes doivent être mis en œuvre dans tous les produits capables de fonctionner à l'extérieur dans la bande 5470 MHz à 5725 MHz.

Les fabricants doivent s'assurer que les produits de radiocommunications ne peuvent pas être configurés pour fonctionner en dehors des règles ISEDC, en particulier, il ne doit pas être possible de désactiver ou modifier les fonctions de protection des radars qui ont été démontrés à ISEDC.

Afin de se conformer à ces exigences de ISEDC, Cambium fournit des variantes du 450 Platform Family exclusivement pour le Canada. Ces variantes ne permettent pas à l'équipement de fonctionner en dehors des règles de ISEDC. En particulier, le fonctionnement des canaux de radio qui chevauchent la bande 5600-5650 MHz est interdite et ces canaux sont définitivement exclus.

ISEDC Approved Antennas

The list of antennas used to obtain ISEDC approvals is provided in the **Reference Information** section of *450 Platform Configuration Guide*.

Antennas externes

Lorsque vous utilisez une version du produit sans antenne intégrée, il peut être nécessaire de réduire la puissance d'émission pour garantir que la limite réglementaire de puissance isotrope rayonnée équivalente (PIRE) n'est pas dépassée. L'installateur doit avoir une bonne compréhension de la façon de calculer le gain de l'antenne réelle et les pertes dans les câbles de connections.

La plage de valeurs admissibles pour un gain maximal de l'antenne et des pertes de câbles de connections sont inclus dans ce guide d'utilisation avec un exemple de calcul. L'interface utilisateur du produit applique automatiquement la limite de puissance menée correct afin de s'assurer qu'il ne soit pas possible pour l'installation de dépasser la limite PIRE, lorsque les valeurs appropriées pour le gain d'antenne et les pertes de câbles d'alimentation sont entrées dans l'interface utilisateur.

Antennes approuvées par ISEDC

La liste des antennes approuvées pour l'opération au Canada est fournie dans le 450 Platform Configuration Guide.

EU Declaration of Conformity

Hereby, Cambium Networks declares that the Cambium 450 Series, 450b Series, 450i Series, and 450m Series Wireless Ethernet Bridges comply with the essential requirements and other relevant provisions of Radio Equipment Directive 2014/53/EU. The declaration of conformity may be consulted at:

https://www.cambiumnetworks.com/eu_dofc

Specific expertise and training for professional installers

To ensure that the 450 Platform Family products – PMP/PTP 450 Series, PMP/PTP 450i Series, PMP 450m Series, and PMP 450 MicroPoP Series are installed and configured in compliance with the requirements of ISEDC and the FCC, installers must have the radio engineering skills and training described in this section.

The installer needs to have basic competence in radio and IP network installation. The specific requirements applicable to the 450 Platform must be gained by reading the following topics:

- Chapter 4: **Preparing for installation** and Chapter 5: **Installation** of *450 Platform Planning and Installation Guide* (this document),
- Chapter 1: **Configuration**, Chapter 2: **Tools**, and Chapter 3: **Operation** of *450 Platform Configuration Guide*, and by performing sample setups at a base workshop before live deployments.

The Cambium Networks technical training program details can be accessed from the following link:

<https://www.cambiumnetworks.com/training/>

Ethernet networking skills

The installer must have the ability to configure IP addressing on a PC, and to set up and control products using a web browser interface.

Lightning protection

To protect outdoor radio installations from the impact of lightning strikes, the installer must be familiar with the normal procedures for site selection, bonding, and grounding. Installation guidelines for the 450 Platform Family can be found in Chapter 2: **System Hardware** and Chapter 3: **System Planning**.

Problems and warranty

Reporting problems

If any problems are encountered when installing or operating this equipment, follow this procedure to investigate and report:

1	Search this document and the software release notes of supported releases.
2	Visit the support website.
3	Ask for assistance from the Cambium product supplier.
4	Gather information from affected units, such as any available diagnostic downloads.
5	Escalate the problem by emailing or telephoning support.

Repair and service

If unit failure is suspected, obtain details of the Return Material Authorization (RMA) process from the support website (<http://www.cambiumnetworks.com/support>).

Hardware warranty

Cambium's standard hardware warranty is for one (1) year from the date of shipment from Cambium Networks or a Cambium distributor. Cambium Networks warrants that hardware will conform to the relevant published specifications and will be free from material defects in material and workmanship under normal use and service. Cambium shall within this time, at its option, either repair or replace the defective product within thirty (30) days of receipt of the defective product. Repaired or replaced products are subjected to the original warranty period but not less than thirty (30) days.

To register PMP and PTP products or activate warranties, visit the support website. For warranty assistance, contact the reseller or distributor. The removal of the tamper-evident seal will void the warranty.



Caution

Using non-Cambium parts for repair could damage the equipment or void warranty. Contact Cambium for service and repair instructions.

Portions of Cambium equipment may be damaged from exposure to electrostatic discharge. Use precautions to prevent damage.

Security advice

Cambium Networks systems and equipment provide security parameters that can be configured by the operator based on their particular operating environment. Cambium recommends setting and using these parameters following industry recognized security practices. Security aspects to be considered are protecting the confidentiality, integrity, and availability of information and assets. Assets include the ability to

communicate, information about the nature of the communications, and information about the parties involved.

In certain instances, Cambium makes specific recommendations regarding security practices, however the implementation of these recommendations and final responsibility for the security of the system lies with the operator of the system.

Warnings, cautions, and notes

The following describes how warnings and cautions are used in this document and in all documents of the Cambium Networks document set.

Warnings

Warnings precede instructions that contain potentially hazardous situations. Warnings are used to alert the reader to possible hazards that could cause loss of life or physical injury. A warning has the following format:



Warning

Warning text and consequence for not following the instructions in the warning.

Cautions

Cautions precede instructions and are used when there is a possibility of damage to systems, software, or individual items of equipment within a system. However, this damage presents no danger to personnel. A caution has the following format:



Caution

Caution text and consequence for not following the instructions in the caution.

Notes

A note means that there is a possibility of an undesirable situation or provides additional information to help the reader understand a topic or concept. A note has the following format:



Note

Note text.

Caring for the environment

The following information describes national or regional requirements for the disposal of Cambium Networks supplied equipment and for the approved disposal of surplus packaging.

In EU countries

The following information is provided to enable regulatory compliance with the European Union (EU) directives identified and any amendments made to these directives when using Cambium equipment in EU countries.



Disposal of Cambium equipment

European Union (EU) Directive 2012/19/EU Waste Electrical and Electronic Equipment (WEEE)

Do not dispose of Cambium equipment in landfill sites. For disposal instructions, refer to

<https://www.cambiumnetworks.com/support/compliance/>

Disposal of surplus packaging

Do not dispose of surplus packaging in landfill sites. In the EU, it is the individual recipient's responsibility to ensure that packaging materials are collected and recycled according to the requirements of EU environmental law.

In non-EU countries

In non-EU countries, dispose of Cambium equipment and all surplus packaging in accordance with national and regional regulations.

Operational restrictions for 6 GHz U-NII devices

1. Operational restrictions include:
 - i. Oil platforms. Operation of standard power access points, fixed client devices, very low power devices, and indoor access points in the 5.925-7.125 GHz band is prohibited on oil platforms.
 - ii. Land vehicles. Operation of standard power access points, fixed client devices, and indoor access points in the 5.925 - 7.125 GHz band is prohibited on vehicles (for example, cars, trains).
 - iii. Boats. Operation of standard power access points, fixed client devices, and indoor APs in the 5.925 - 7.125 GHz band is prohibited on boats.
 - iv. Aircraft. Standard power access points, fixed client devices, very low power devices, and indoor access points in the 5.925 - 7.125 GHz band are prohibited from operating on aircraft,

except that very low power devices and indoor access points are permitted to operate in the 5.925 - 6.425 GHz bands in large aircraft while flying above 10,000 feet.

- v. Unmanned aircraft systems. Operation of transmitters in the 5.925 - 7.125 GHz band is prohibited for control of or communications with unmanned aircraft systems.

Chapter 1: Product Description

This chapter provides a high-level description of 450 Platform Family products. It describes in general terms the function of the product, the main product variants and the main hardware components. The following topics are described in this chapter:

- [Overview of the 450 Platform Family](#)
- [Wireless operation](#)
- [System management](#)

Overview of the 450 Platform Family

This section introduces key features, typical uses, product variants, and components of the 450 Platform Family.

Purpose

Cambium 450 Platform Family products are designed for Ethernet bridging over PTP and PMP microwave links in unlicensed and lightly-licensed frequency bands 900 MHz, 2.4 GHz, 3.5/3.65 GHz, and 4.9 to 5.925 GHz.

Users must ensure that the 450 Platform Family complies with local operating regulations.

The 450 Platform Family acts as a transparent bridge between two or more segments of the operator's network. In this sense, it can be treated as a virtual wired connection among points. The 450 Series platform forwards 802.3 Ethernet frames destined for the other part of the network and filters frames it does not need to forward.

450 Platform Family

The 450 Series platform includes the following:

- [PMP 450m Series](#)
- [PMP/PTP 450i Series](#)
- [PMP/PTP 450b Series](#)
- [PMP/PTP 450 Series](#)
- [PMP 450 MicroPoP Series](#)
- [PMP/PTP 450b Retro Series](#)

- [PMP/PTP 450b Connectorized Series](#)
- [450v Series](#)

PMP 450m Series

The PMP 450m Series APs are based on Multi-User-Multiple-Input and Multiple-Output (MU-MIMO) technology. By combining a sophisticated beam forming antenna array with multiple transceivers, Cambium Networks is using leading edge technology to provide a substantial shift upward in capacity per sector.

Key features

Cambium PMP 450m Series APs offer the following benefits:

- MU-MIMO APs provide up to 900 Mbps in 20 MHz channel bandwidth and up to 1.4 Gbps in a 40 MHz channel, depending upon SMs position within sector. Even higher data rates are possible by using 5 ms frame sizes.
- Releases 16.0 and beyond support 3 GHz APs, as well as MU-MIMO in the uplink (UL) direction.
- Release 22.2 introduces support on the 5 GHz 450m to identify and cancel interference in the uplink direction. Refer to the *PMP/PTP 22.2 Release Notes* and the *PMP/PTP Configuration Guide - version 22.2* for more details on this feature. Note that enabling Interference Cancellation disables MU-MIMO scheduling in the uplink direction. All uplink traffic is now scheduled one SM at a time.
- PMP 450m APs are compatible with existing PMP 450/450i Series Subscriber Modules (SM), providing an easy network upgrade path. This benefits to reuse existing SMs (i.e. capital investment). With releases 15.1.3 and beyond, 5 GHz PMP 450m also provides basic sector mode support for 430 SMs.
- 3x higher throughput packet rate compared to 450 Series.
- 5 GHz integrated with 14x14 MU-MIMO antenna; 3 GHz integrated with 8x8 MU-MIMO antenna.
- 5 GHz ports: Gigabit copper/power port combined, 100BASE-T port with power out and SFP port, 2.5G Copper SFP.
- 3 GHz ports: Gigabit copper Ethernet port without Power, Ethernet, 100/1000BASE-T Auxiliary with power out, SFP1, SFP2.
- 45 bps/Hz spectral efficiency in a single sector and 90 bps/Hz in a back-to-back frequency reuse deployment.

Below table provides a summary of the main PMP 450m Series APs characteristics.

Table 1: Main characteristics of the PMP 450m Series APs

Characteristic	Value
Topology	PMP
Wireless link condition	LOS, near LOS or non-LOS
Range	PMP: Up to 40 mi (or 64 km)
Duplexing	TDD (symmetric and asymmetric)
Connectivity	1000BASE-T Ethernet Main port with PoE input
Operating frequencies	4.9 to 5.925 GHz 3.3 to 3.9 GHz
Tx EIRP	5 GHz - 48 dBm 3 GHz - 52 dBm
Channel bandwidth	5, 7, 10, 15, 20, 30, and 40 MHz
High spectral efficiency	90 bps/Hz
Timing synchronization	CMM5 or UGPS/cnPulse
Data rate	Up to 900 Mbps with 20 MHz channel bandwidth and up to 1.4 Gbps in a 40 MHz channel. Additional data rate improvements are available by using a 5 ms frame size.

Frequency bands

The PMP 450m Series AP operates in the following frequency ranges:

- 4900 to 5925 MHz
- 3300 to 3900 MHz

Hardware components

The ODU (Outdoor unit) is a self-contained transceiver unit that houses both radio and networking electronics.

The PMP 450m Series is supplied in the following configurations:

Table 2: PMP 450m Series hardware configurations

ODU	Frequency	ODU type	
5 GHz PMP 450m AP	4900 to 5925 MHz	Integrated	15 dBi, 90° MU-MIMO sector antenna
3 GHz PMP 450m AP	3300 to 3900 MHz	Integrated	16 dBi, 90° MU-MIMO sector antenna

PMP/PTP 450i Series

The PMP/PTP 450i Series is a high performance wireless bridge for Ethernet traffic. It is capable of operating in line-of-sight (LOS), near-LOS, and non-LOS propagation conditions. It supports 900 MHz, 3 GHz, and 4.9 to 5.925 GHz frequency bands.

Key features

The PMP/PTP 450i Series has the extensive Quality of Service (QoS) involving traffic classification, traffic policy, and shaping capability.

Cambium PMP/PTP 450i Series APs offer the following benefits:

- Cambium Networks high performing PMP solution, with up to 310 Mbps (40 MHz channel bandwidth and 5 ms Frame Period) usable throughput for PMP and PTP
- State-of-the-art MIMO technology
- Upto 7.5 bps/Hz spectral efficiency
- Increased packet processing rate
- Efficient GPS synchronization, scheduled TDD operation for easy AP/BHM site deployment and performance that is consistent regardless of SM/BHS loading
- A range of cost-effective subscriber device solutions to meet the business case of any network application
- MIMO B Mode: This technique provides the ability to double the throughput of a radio transmission under proper RF conditions. Different data streams are transmitted simultaneously on two different antennas
- MIMO A mode: This mode of operation has the same modulation levels as the MIMO-B mode, namely: QPSK, 16-QAM, 64-QAM and 256-QAM. This mode increases system reliability in the links.
- GPS synchronization via CMM4, CMM5, or UGPS

Below table gives a summary of the main PMP/PTP 450i Series characteristics.

Table 3: Main characteristics of the PMP/PTP 450i Series

Characteristic	Value
Topology	PMP/PTP
Wireless link condition	LOS, near LOS or non-LOS
Range	<ul style="list-style-type: none"> • PTP: Up to 186 mi (or 299 km) depending on configuration for all bands • PMP: Up to 40 mi (or 64 km) for 5 GHz band • PMP: Up to 120 mi (or 193 km) for 900 MHz band
Duplexing	TDD (symmetric and asymmetric)
Connectivity	1000BASE-T Ethernet main port with PoE input
Operating frequencies	<ul style="list-style-type: none"> • 902 to 928 MHz • 3.3 to 3.9 GHz • 4.9 to 5.925 GHz
Tx Power - conducted	<ul style="list-style-type: none"> • Max 25 dBm (3 GHz) • Max 27 dBm (5 GHz) • Max 25 dBm (900 MHz)
Channel bandwidth	5, 7, 10, 15, 20, 30, and 40 MHz  <div style="border: 1px solid black; background-color: #e1f5fe; padding: 5px; display: inline-block;"> <p>Note</p> <p>All bands do not support all channel bandwidths. For more information, refer to this link.</p> </div>
Spectral efficiency	Up to 7.5 bps/Hz
Timing synchronization	CMM4, CMM5, or UGPS/cnPulse
Data rate	Up to 310 Mbps (40 MHz channel Bandwidth) for PMP/PTP

Frequency bands

The PMP/PTP 450i Series ODU can operate in the following bands:

- 900 MHz band: 902 to 928 MHz
- 3 GHz band: 3300 to 3900 MHz
- 5 GHz band: 4900 to 5925 MHz



Note

900 MHz, 3 GHz, and 5 GHz bands with different frequencies require different hardware components.

Hardware components

The ODU is a self-contained transceiver unit that contains both radio and networking electronics. The main hardware components of the PMP/PTP 450i Series are as follows:

- PMP 450i AP
- PMP 450i SM
- PTP 450i BH (BHM/BHS)

The PMP/PTP 450i Series is supplied in the following configurations:

Table 4: PMP/PTP 450i Series hardware configurations

ODU	Frequency	ODU type	
PMP 450i AP	902 to 928 MHz	Connectorized	Use with an external antenna
		Integrated	17 dBi, 90° sector dual slant antenna
	3.3 to 3.9 GHz	Connectorized	Use with an external antenna
		Integrated	16 dBi, 90° sector antenna
4.9 to 5.925 GHz (support 4.9, 5.1, 5.2, 5.4 and 5.8 GHz)	Connectorized	Use with an external antenna	
	Integrated	Use with an external antenna	
PMP 450i SM	3.3 to 3.9 GHz	Integrated	19 dBi, SM/BH with MARS antenna
		Connectorized	Use with an external antenna
	4.9 to 5.925 GHz (support 4.9, 5.1, 5.2, 5.4 and 5.8 GHz)	Integrated	23 dBi flat panel antenna
		Connectorized	Use with an external antenna
PTP 450i BH	3.3 to 3.9 GHz	Integrated	19 dBi, SM/BH with MARS antenna
		Connectorized	Use with an external antenna
	4.9 to 5.925 GHz (support 4.9, 5.1, 5.2, 5.4 and 5.8 GHz)	Integrated	23 dBi flat panel antenna
		Connectorized	Use with an external antenna



Note

The BH ODU can be configured as a BHM or a BHS in PTP mode.

PMP/PTP 450b Series

The PMP/PTP 450b Series of products offer high-performance wireless PMP SMs that can also support PTP operation. Each radio is capable of operating in LOS, near-LOS, and non-LOS propagation conditions. Variants support the 3 GHz, the 4.9 to 5.925 GHz, and the 5.7 to 6.3 GHz frequency bands.

6 GHz Frequency band support: With the added support for the 6 GHz frequency band, the PMP/PTP 450b Series extends its capabilities to offer enhanced performance and flexibility for wireless communication deployments. Operating in the 6 GHz band opens up additional spectrum resources, allowing for increased capacity, reduced interference, and improved overall performance. It is important to note that using the 6 GHz band requires obtaining authorization from the Automatic Frequency Controller (AFC) in the US and Canada.

Key features

Cambium PMP/PTP 450b Series APs offer the following benefits:

- **In the 5 GHz bands:** Ultra-wide band radios support the entire band from 4.9 to 5.925 GHz, providing extensive coverage and flexibility for wireless communication deployments.
- **In the 6 GHz band:** With newly added support for the 6 GHz frequency band (5.7 to 6.3 GHz), users can leverage additional spectrum resources for enhanced performance and capacity. Automatic Frequency Coordination (AFC) system requirements for 6 GHz band operation require the use of a GPS Receiver to obtain latitude, longitude, and altitude parameters, ensuring compliance with regulatory requirements and optimal frequency utilization.
- **In the 3 GHz band:** Radios support the 3.3 to 3.9 GHz range, ensuring compatibility and optimal performance in this frequency band.
- **Gigabit Ethernet interface:** Provides maximum transfer rates to the device, enabling high-speed data transmission and efficient network operation.
- **3.5 mm audio jack:** Allows direct connection of headphones without any adapters, facilitating convenient audio monitoring and troubleshooting.
- **Updated FPGA:** Enhances packet processing power more than 4 times that of the 450 SM, ensuring efficient data processing and optimized network performance.
- **High Aggregate Throughput:** Capable of up to 300 Mbps aggregate in a 40 MHz channel, delivering high-speed data transfer for demanding applications and network requirements.

gives a summary of the main PMP/PTP 450b Series characteristics

Table 5: Main characteristics of the PMP/PTP 450b Series

Characteristic	Value
Topology	PMP/PTP
Wireless link condition	LOS, near LOS or non-LOS
Range	<ul style="list-style-type: none"> • PTP: Up to 186 mi (or 299 km) depending on the configuration for all bands • PMP: Up to 40 mi (or 64 km)
Duplexing	TDD (symmetric and asymmetric)
Connectivity	100/1000BASE-T Ethernet main port with PoE input
Operating frequencies	<ul style="list-style-type: none"> • 3.3 to 3.9 GHz • 4.9 to 5.925 GHz • 5.7 to 6.3 GHz
Tx Power - conducted	<ul style="list-style-type: none"> • Maximum 29 dBm (3 GHz) • Maximum 27 dBm (5/6 GHz)
Channel bandwidth	5, 7, 10, 15, 20, 30, and 40 MHz  <div style="border: 1px solid black; background-color: #e1f5fe; padding: 5px; margin-top: 5px;"> <p>Note All bands do not support all channel bandwidths. For more information, refer to this link.</p> </div>
Spectral efficiency	Up to 7.5 bps/Hz
Timing synchronization	CMM4, CMM5, or UGPS/cnPulse
Data rate	Up to 310 Mbps (40 MHz channel bandwidth).

Hardware components

The ODU is a self-contained transceiver unit that houses both radio and networking electronics. Each radio supports operation as a PMP 450b SM or a PTP 450b BH (BHM/BHS). With the addition of support for the 6 GHz frequency band (5.7 to 6.3 GHz), users can now take advantage of expanded spectrum resources for enhanced performance and capacity. It is essential to note that earlier versions of the 5 GHz 450b radios supported only one mode of operation—either PMP 450b SM or PTP 450b BH (BHM/BHS).

The 450b Series is supplied in the following configurations:

Table 6: PMP/PTP 450b Series hardware configurations

ODU	Frequency	ODU type	Antenna Gain / Type
PMP/PTP 450b	3.3 to 3.9 GHz	High Gain	20 dBi Dish antenna
	4.9 to 5.925 GHz (supports 4.9, 5.1, 5.2, 5.4 and 5.8 GHz bands)	Mid-Gain	16 dBi integrated antenna
		High Gain	23 dBi Dish antenna
	5.7 to 6.3 GHz	High Gain	23 dBi Dish antenna

PMP/PTP 450 Series

Cambium Networks PMP/PTP 450 Series networks are designed for wireless PMP and PTP links in the unlicensed/licensed 900 MHz, 2.4 GHz, 3.5 GHz, 3.65 GHz, 5.4 GHz and 5.8 GHz bands. Users must ensure that the PMP/PTP 450 Series complies with local operating regulations.

The PMP/PTP 450 Series enables network operators to grow their business by offering more capacity for data, voice, and video applications.

Key features

The Cambium Networks PMP/PTP 450 Series offers the following benefits:

- Cambium Networks PMP and PTP solution, with up to 310 Mbps usable throughput
- State-of-the-art MIMO technology
- Efficient GPS synchronized, scheduled TDD operation for easy AP site deployment and performance that is consistent regardless of subscriber loading
- A range of cost-effective subscriber device solutions to meet the business case of a network application
- MIMO-B Mode: This technique provides the ability to double the throughput of a radio transmission under proper RF conditions. Different data streams are transmitted simultaneously on two different antennas.
- MIMO-A Mode: This mode of operation using the same modulation levels as the MIMO-B mode, namely: QPSK, 16-QAM, 64-QAM, and 256-QAM but it provides an additional combining gain.

The below table gives a summary of PMP/PTP 450 Series products main characteristics.

Table 7: Main characteristics of the PMP/PTP 450 Series

Characteristic	Value
Topology	PMP/PTP

Characteristic	Value
Wireless link condition	LOS, near LOS or non-LOS
Range	<ul style="list-style-type: none"> Up to 40 mi (or 64 km) for PMP Up to 186 mi (or 299 km) for PTP
Duplexing	TDD (symmetric and asymmetric)
Connectivity	100BASE-T Ethernet main port with PoE input
Operating frequencies	900 MHz, 2.4 GHz, 3.5 GHz, 3.65 GHz, and 5 GHz
Tx Power - conducted	<ul style="list-style-type: none"> max 22 dBm (2.4 GHz and 5 GHz) max 25 dBm (3.5 GHz and 3.65 GHz) max 25 dBm (900 MHz - PMP 450 SM and BH)
Channel bandwidth	5, 7, 10, 15, 20, 30, and 40 MHz  <div style="border: 1px solid black; background-color: #e1f5fe; padding: 5px; display: inline-block;"> <p>Note All bands do not support all channel bandwidths. For more information, refer to this link.</p> </div>
High spectral efficiency	Up to 7.5 bps/Hz
Timing synchronization	CMM4, CMM5, internal GPS, or UGPS/cnPulse
Data rate	Up to 310 Mbps (40 MHz channel Bandwidth) for PMP/PTP

Frequency bands

The PMP/PTP 450 Series ODU can operate in the following bands:

- 900 MHz band: 902 to 928 MHz (SM and BH)
- 2.4 GHz band: 2400 to 2483 MHz
- 3.5 GHz band: 3300 to 3600 MHz
- 3.65 GHz band: 3500 to 3850 MHz
- 5 GHz band: 5470 to 5875 MHz

Hardware components

The main hardware components of the PMP/PTP 450 are as follows:

- PMP 450 AP
- PMP 450 SM

- PTP 450 BH (BHM/BHS)

The PMP/PTP 450 is supplied in the following configurations:

Table 8: PMP/PTP 450 Series hardware configurations

ODU	Frequency	ODU type	
PMP 450 AP	2.4 GHz	Connectorized	Use with an external antenna
		Integrated	18 dBi Dual Slant
	3.5/3.65 GHz	Connectorized	Use with an external antenna
		Integrated	16 dBi Dual Slant
	5 GHz (5.4 and 5.8 GHz)	Connectorized	Use with an external antenna
PMP 450 SM	900 MHz	Connectorized	Use with an external antenna
	2.4 GHz	Connectorized	Use with an external antenna
		Integrated	7 dBi Dual Slant, integrated patch
	3.5/3.65 GHz	Connectorized	Use with an external antenna
		Integrated	8 dBi Dual Slant, integrated patch
		Integrated	19 dBi Flat Plate, integrated patch
	5 GHz (5.4 and 5.8 GHz)	Connectorized	Use with an external antenna
		Integrated	9 dBi H+V, integrated patch
		Integrated	25 dBi H+V, Integrated dish
	PTP 450 BH	902 to 928 MHz	Connectorized
3.5/3.65 GHz		Connectorized	Use with an external antenna
		Integrated	8 dBi Dual Slant
5 GHz (5.4 and 5.8 GHz)		Connectorized	Use with an external antenna
		Integrated	9 dBi H+V



Note

The BH ODU can be configured as a BHM or a BHS in PTP mode.

PMP 450 MicroPoP Series

The PMP 450 MicroPoP Series is a high-performance wireless bridge for Ethernet traffic. It is an AP that is based on the PMP 450b Series hardware, available with an integrated Omni or Sector antenna, and a

Connectorized option.

Key features

The Cambium PMP 450 MicroPoP Series offers the following benefits:

- Ultra-wide band radios support the entire band from 4.9 GHz to 5.925 GHz
- Gigabit Ethernet Interface provides the maximum transfer rates to the device
- Capable of up to 300 Mbps aggregate in a 40 MHz channel
- Supports a range of up to 2 miles and a number of subscribers up to 20
- To unlock the full capabilities of the platform (range up to 40 miles and number of subscribers up to 238) a license key is available for purchase
- Efficient GPS synchronized, scheduled TDD operation for easy AP site deployment and performance that is consistent regardless of subscriber loading



Note

MicroPoP Omni and Sector models are not provisioned with a 3.5mm audio jack, but support an integrated GPS module with an internal active antenna. MicroPoP Connectorized model is equipped with an RF GPS port for the connection of an external active GPS antenna pack.

Table 9: PMP 450 MicroPoP Series characteristics

Characteristic	Value
Topology	PMP
Wireless link condition	LOS, near LOS, or non-LOS
Range	Up to 2 miles License key available to unlock range up to 40 miles
Duplexing	TDD (symmetric and asymmetric)
Connectivity	100/1000BASE-T Ethernet main port with PoE input
Operating frequencies	4.9 to 5.925 GHz
Tx Power - conducted	Max 27 dBm (5 GHz)
Channel bandwidth	5, 7, 10, 15, 20, 30, and 40 MHz
Spectral efficiency	Up to 7.5 bps/Hz
Timing synchronization	CMM4, CMM5, or internal/external GPS
Data rate	Up to 300 Mbps (40 MHz channel Bandwidth).

Frequency bands

The PMP 450 MicroPoP Series ODU can operate in the following band:

- 5 GHz band: 4900 to 5925 MHz

Hardware components

The ODU is a self-contained transceiver unit that contains both radio and networking electronics. The main hardware components of the PMP 450 MicroPoP Series are as follows:

- PMP 450 MicroPoP Omni AP
- PMP 450 MicroPoP Sector AP
- PMP 450 MicroPoP Connectorized AP

The PMP 450 MicroPoP Series is supplied in the following configuration:

Table 10: PMP 450 MicroPoP Series hardware configurations

ODU	Frequency	ODU type	
PMP 450 MicroPoP AP	4.9 to 5.925 GHz (support 4.9, 5.1, 5.2, 5.4 and 5.8 GHz)	Integrated Omni	9 dBi Integrated antenna
		Integrated Sector	13 dBi integrated antenna
		Connectorized	External antenna

PMP/PTP 450b Retro Series

The PMP/PTP 450b Retro Series is a high-performance wireless bridge for Ethernet traffic. It is an SM based on the PMP 450b Series hardware that can also support PTP operation. It is available with an integrated antenna and with the same form factor as the PMP 450 SM, which allows reuse of the same reflector dish.

Key features

The Cambium PMP/PTP 450b Retro Series offers the following benefits:

- Ultra-wide band radios support the entire band from 4.9 to 5.925 GHz
- Gigabit Ethernet Interface provides the maximum transfer rates to the device
- 3.5 mm audio jack allows direct connection of headphones without any adapters
- Updated FPGA enhances Packet Processing Power more than 4 times that of the 450m SM
- Capable of up to 300 Mbps aggregate in a 40 MHz channel

- The same form factor of the PMP 450 SM
- The form factor allows the use of existing Offset Reflector dishes

Table 11: PMP 450 Retro Series characteristics

Characteristic	Value
Topology	PMP, PTP
Wireless link condition	LOS, near LOS, or non-LOS
Range	PMP: up to 40 miles
Duplexing	TDD (symmetric and asymmetric)
Connectivity	100/1000BASE-T Ethernet main port with PoE input
Operating frequencies	4.9 to 5.925 GHz
Tx Power - conducted	Maximum 27 dBm
Channel bandwidth	5, 10, 15, 20, 30, and 40 MHz
Spectral efficiency	Up to 7.5 bps/Hz
Timing synchronization	CMM4, CMM5, or UGPS/cnPulse
Data rate	Up to 300 Mbps (40 MHz channel Bandwidth).

Frequency bands

The PMP/PTP 450b Retro Series ODU can operate in the following band:

- 5 GHz band: 4900 to 5925 MHz

Hardware components

The ODU is a self-contained transceiver unit that houses both radio and networking electronics. The main hardware components of the PMP/PTP 450b Retro Series are as follows:

- PMP/PTP 450b Retro SM

The PMP/PTP 450b Retro Series is supplied in the following configuration:

Table 12: PMP/PTP 450b Retro Series hardware configurations

ODU	Frequency	ODU type	
PMP/PTP 450b Retro	4.9 to 5.925 GHz (support 4.9, 5.1, 5.2, 5.4 and 5.8 GHz)	Integrated	8 dBi Integrated antenna

PMP/PTP 450b Connectorized Series

The PMP/PTP 450b Connectorized Series is a high-performance wireless bridge for Ethernet traffic. It is a SM based on the PMP 450b Series hardware that can also support PTP operation, available with an integrated antenna and with the same form factor as the PMP 450 SM, which allows the reuse of the same reflector dish.

Key features

The Cambium PMP/PTP 450b Connectorized Series offers the following benefits:

- Capable of up to 300 Mbps aggregate in a 40 MHz channel
- The same form factor of the PMP 450 SM
- The form factor allows use of existing Offset Reflector dishes
- Ultra-wide band radios support the entire band from 4.9 to 5.925 GHz
- Gigabit Ethernet Interface provides the maximum transfer rates to the device
- 3.5 mm audio jack allows direct connection of headphones without any adapters
- Updated FPGA enhances Packet Processing Power more than 4 times that of the 450m SM

Table 13: PMP 450b Connectorized Series characteristics

Characteristic	Value
Topology	PMP, PTP
Wireless link condition	LOS, near LOS, or non-LOS
Range	PMP: up to 40 miles
Duplexing	TDD (symmetric and asymmetric)
Connectivity	100/1000BASE-T Ethernet main port with PoE input
Operating frequencies	4.9 to 5.925 GHz
Tx Power - conducted	Max 27 dBm
Channel bandwidth	5, 10, 15, 20, 30, and 40 MHz
Spectral efficiency	Up to 7.5 bps/Hz
Timing synchronization	CMM4, CMM5, or UGPS/cnPulse
Data rate	Up to 300 Mbps (40 MHz channel Bandwidth).

Frequency bands

The PMP/PTP 450b Connectorized Series ODU can operate in the 5 GHz band (4900 to 5925 MHz).

Hardware components

The ODU is a self-contained transceiver unit that houses both radio and networking electronics. PMP/PTP 450b Connectorized SM is the main hardware component of the PMP/PTP 450b Retro Series.

The PMP/PTP 450b Connectorized Series is supplied in the following configuration:

Table 14: PMP/PTP 450b Connectorized Series hardware configurations

ODU	Frequency	ODU type	Antenna type
PMP/PTP 450b Connectorized	4.9 to 5.925 GHz (supports 4.9, 5.1, 5.2, 5.4, and 5.8 GHz)	Connectorized	External antenna

450v Series

The 450v Series is a high performance wireless bridge for Ethernet traffic. It is capable of operating in line-of-sight (LOS), near-LOS, and non-LOS propagation conditions. It supports 5.1 to 7.1 GHz frequency bands. Both PMP and PTP operation are supported.

Key features

The Cambium 450v Series offers the following benefits:

- Cambium delivers a high-performing PMP solution, providing up to 310 Mbps usable throughput for PMP and PTP per component carrier, supporting up to three component carriers (*) with a 40 MHz channel bandwidth and a 5 ms Frame Period.
- Supports the 5 GHz and 6 GHz bands.
- 450v 4x4 SM supports up to three component carriers with 40 MHz bandwidth each (*).
- 450v 2x2 SM supports up to two component carriers with 40 MHz bandwidth each.
- Utilizes state-of-the-art MIMO (Multi In Multi Out) technology.
- Achieves up to 7.5 bps/Hz spectral efficiency.
- Increases Packet Processing rate.
- Operates with efficient GPS-synchronized, scheduled TDD operation for easy AP/BHM site deployment, ensuring consistent performance regardless of SM/BHS loading.

- Offers a range of cost-effective subscriber device solutions to meet the business case of any network application.
- MIMO B Mode: Doubles the throughput of a radio transmission under proper RF conditions by simultaneously transmitting different data streams on two different antennas.
- MIMO-A mode: Operates with the same modulation levels as the MIMO-B mode (QPSK, 16-QAM, 64-QAM, and 256-QAM) to increase system reliability in the links*.
- On-board GPS synchronization on AP and SM.
- Audio Jack for antenna alignment and external GPS sync on AP and SM.



Note

* Release 24.2.2 supports only two component carriers. Support for more than two component carriers is planned for a future release.

The 450v Series features extensive Quality of Service (QoS) capabilities, including traffic classification, traffic policy, and shaping capability.

Table 15 gives a summary of 450v Series products main characteristics.

Table 15: Main characteristics of the 450v Series

Characteristic	Value
Topology	PMP/PTP
Wireless link condition	LOS, near LOS or non-LOS
Range	Up to 40 mi (or 64 km) in PMP mode, up to 124 mi (200km) in PTP mode
Duplexing	TDD (symmetric and asymmetric)
Connectivity	<ul style="list-style-type: none"> • 1000BASE-T Ethernet Main port with PoE input • 1000BASE-T Ethernet Aux port with PoE output • 10 Gbps SFP+ interface
Operating frequencies	5.150 to 7.125 GHz
Tx Power - conducted	<ul style="list-style-type: none"> • Maximum 28 dBm (5.150 GHz - 5.925 GHz) • Maximum 20 dBm (5.975 GHz - 7.125 GHz)
Channel bandwidth	5, 10, 15, 20, 30, and 40 MHz

Characteristic	Value
High spectral efficiency	Up to 7.5 bps/Hz
Timing synchronization	Onboard GPS
Data rate	Up to 310 Mbps (40 MHz channel Bandwidth) for PMP per component carrier, up to 4 component carriers (*)

Frequency bands

The 450v Series ODU can operate in the following bands:

- 5 GHz band: 5.150 GHz - 5.925 GHz
- 6 GHz band: 5.975 GHz - 7.125 GHz

Hardware components

The ODU (Outdoor unit) is a self-contained transceiver unit that houses both radio and networking electronics. The main hardware components of the 450v Series are as follows:

- 450v AP (4x4)
- 450v SM (4x4)
- 450v SM (2x2)
- 450v BHM/BHS (4x4)
- 450v BHM/BHS (2x2)
- 450b6

The 450v is supplied in the following configurations:

Table 16: 450v Series hardware configurations

ODU	Frequency	Antenna	ODU type	Channel Bandwidth	Maximum Tx Power
5/6 GHz 450v AP (4x4)	5.150 GHz – 7.125 GHz	Integrated 4x4 Sector Antenna	Integrated	5, 10, 15, 20, 30, 40 MHz	28 dBm (for 5 GHz) 20 dBm (for 6 GHz)
5/6 GHz 450v SM (4x4)	5.150 GHz – 7.125 GHz	Integrated 4x4 Antenna	Integrated	5, 10, 15, 20, 30, 40 MHz	28 dBm (for 5 GHz) 20 dBm (for 6 GHz)

ODU	Frequency	Antenna	ODU type	Channel Bandwidth	Maximum Tx Power
5/6 GHz 450v SM (2x2)	5.150 GHz – 7.125 GHz	Integrated 2x2 Antenna	Integrated	5, 10, 15, 20, 30, 40 MHz	28 dBm (for 5 GHz) 20 dBm (for 6 GHz)
5/6 GHz 450v BHM/BHS (4x4)	5.150 GHz – 7.125 GHz	Integrated 4x4 Antenna	Integrated	5, 10, 15, 20, 30, 40 MHz	28 dBm (for 5 GHz) 20 dBm (for 6 GHz)
5/6 GHz 450v BHM/BHS (2x2)	5.150 GHz – 7.125 GHz	Integrated 2x2 Antenna	Integrated	5, 10, 15, 20, 30, 40 MHz	28 dBm (for 5 GHz) 20 dBm (for 6 GHz)
5/6 GHz 450b6 SM Integrated Antenna	5.150 GHz – 7.125 GHz	Integrated 2x2 Antenna	Integrated	5, 10, 15, 20, 30, 40 MHz	27 dBm (for 5 GHz) 20 dBm (for 6 GHz)

Supported interoperability for 450m/450i/450b/450/450v series

The supported interoperability among various 450m/450i/450 series hardware are listed below:

Table 17: Supported interoperability for PMP

Band	AP	SM
5.1, and 5.8 GHz	450v	450v SM (4x4), 450v SM (2x2), PMP 450i SM, PMP 450b SM, PMP 450b Retro SM, and PMP 450b Connectorized SM*
U-NII-5, U-NII-6, and U-NII-7	450v	450v SM (4x4), 450v SM (2x2), and 450b6 *
4.9, 5.1, 5.2 and 5.9 GHz	PMP 450m AP	PMP 450i SM, PMP 450b SM, PMP 450b Retro SM, and PMP 450b Connectorized SM
4.9, 5.1, 5.2 and 5.9 GHz	PMP 450i AP	PMP 450i SM, PMP 450b SM, PMP 450b Retro SM, and PMP 450b Connectorized SM
	PMP 450 MicroPoP	
5.4 and 5.8 GHz	PMP 450m AP	PMP 450i SM, PMP 450 SM, PMP 450d SM, PMP 450b SM, PMP 450b Retro SM, PMP 450b Connectorized SM, and PMP 430 SM
	PMP 450i AP	
	PMP 450 AP	
	PMP 450 MicroPoP	

Band	AP	SM
3.5 and 3.65 GHz	PMP 450 AP	PMP 450 SM, PMP 450i SM, PMP 450b SM
	PMP 450i AP	PMP 450i SM, PMP 450 SM, PMP 450b SM
	PMP 450m AP	PMP 450i SM, PMP 450 SM, PMP 450b SM
2.4 GHz	PMP 450 AP	PMP 450 SM
900 MHz	PMP 450i AP	PMP 450 SM

* The 450b6 SM supports the 5.8 GHz band and part of the U-NII-5 spectrum.

Table 18: Supported Interoperability for PTP

Band	BH
900 MHz	PTP 450/450i BHM and BHS
3.5 and 3.65 GHz	PTP 450/450b/450i BHM and BHS
4.9, 5.1, 5.2, 5.4 and 5.8 GHz	PTP 450b/450i/450b Retro BHM and BHS
5.4 and 5.8 GHz	PTP 450/450b/450i/450/450b Retro BHM and BHS

Typical deployment

The 450 Platform Family is an all outdoor solution consisting of a wireless bridge across sites. Each site installation consists of an Integrated or Connectorized ODU and a power supply (PSU). The ODU provides only the Ethernet port interface. This interface provides proprietary Power over Ethernet (PoE) and connection to the management and/or data networks.



Note

PMP 450m 3 GHz has a separate power and data interface.

Figure 1: PMP/PTP 450 Platform Family typical bridge deployment

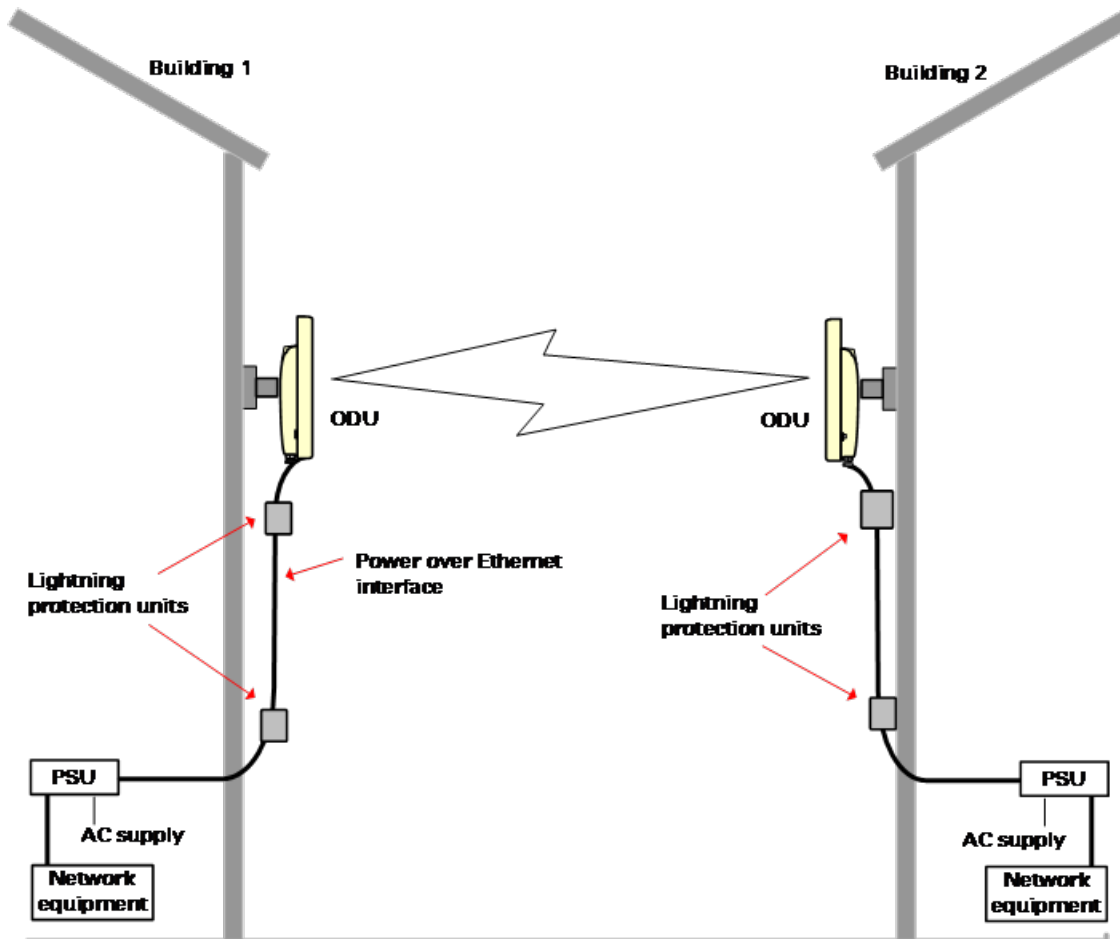

Note

Lightning protection and power supply differs between variants.

Point-to-Multipoint (PMP)

The PMP configuration of 450 Platform Family consists of AP and SM ODU. The radio link operates on a single frequency channel in each direction using Time Division Duplexing (TDD). The AP operates in Time Division Multiple Access (TDMA) mode to service multiple SMs.

Applications for the PMP Series include:

- Urban area network extension
- Network extension into areas with foliage
- High throughput enterprise applications
- nLOS video surveillance in metro areas

PTP (Backhaul)

The PTP configuration of 450 Platform Family consists of two BH (Backhaul) ODUs. The customer can decide, via software configuration, if this unit is a BHM (Backhaul Master) or a BHS (Backhaul Slave). The radio link operates on a single frequency channel using TDD. The BHM operates in TDMA mode to service the BHS.

Applications for the PTP Series include:

- Enterprise access
- nLOS video surveillance
- Leased line replacements and backup solutions
- Network extension

Product variants

The 450 Platform Family is available in the following product variants:

- The ODU is supplied in the following regional variants:
 - FCC: intended for deployment in the USA
 - IC: intended for deployment in Canada
 - EU: intended for deployment in countries of the European Union or other countries following ETSI regulations
 - Rest of the World (RoW): intended for deployment in countries other than USA and EU countries.
- Integrated, Connectorized ODUs:
 - Integrated units contain an integrated antenna.
 - Connectorized units are designed to connect to an external antenna.
 - 450b High Gain units operate with a purpose designed dish.
- Standard or ruggedized ODUs:
 - APs and SMs are supplied in either standard or ruggedized versions.
 - 450b range is supplied to the IP55 standard, but an IP67 conversion kit is available for the High Gain units.

- Encryption:
 - Most ODU variants in the range support AES 128 or AES 256 encryption.
 - ODU variants are available with weaker or no encryption for export purposes.
- Power supply modules: A variety of Power Supplies/Power-over-Ethernet (PoE) supplies are available
 - All power injectors/power supplies in the Cambium Networks range are designed for an indoor environment.
 - Different ODUs require different power requirements, so be sure to select the correct power supply.
- Surge protection units: A range of surge protectors is available to suit different ODUs
 - The Gigabit Surge Suppressor provides a path to ground (Protective Earth) that protects connected radio equipment from near-miss lightning strikes.
 - LPU: LPUs are installed in the ports copper drop cables to provide transient voltage surge suppression.
 - A DC LPU provides transient voltage surge suppression for 3 GHz PMP 450.
- Cabling:
 - AC line cords: AC line cords are supplied separately from the power supply. Regional variants are available.
 - Antennas and antenna cabling: Connectorized ODUs require RF cables to connect to external antennas.
 - Ethernet cabling: All configurations require a copper Ethernet Cat5e connection from the ODU (Ethernet port) to the PoE.
 - Ground cables: ODU, LPUs, and outdoor copper Ethernet cables are bonded to the site grounding system using ground cables.

For more information about these components, including interfaces, specifications, and Cambium Networks part numbers, refer to [Chapter 2: System Hardware](#).

Wireless operation

This section describes how the 450 Platform Family wireless link is operated, including modulation modes, power control and security.

Time Division Duplexing

The system uses Time Division Duplexing (TDD) – one channel alternately transmits and receives rather than using one channel for transmitting and a second channel for receiving. The radio link operates on a

single frequency channel in each direction using TDD. The AP operates in TDMA mode to service multiple SMs. To accomplish TDD, the AP/BHM must sync with its SM/BHS. Furthermore, collocated APs/BHMs must be synced together – an unsynchronized AP/BHM that transmits during the receive cycle of a collocated AP/BHM can prevent a second AP/BHM from being able to decode the signals from its APs/BHSs. In addition, across a geographical area, APs/BHMs that can hear each other benefit from using a common sync to further reduce self-interference within the network.

Modules use TDD on a common frequency to divide frames for uplink (orange) and downlink (green) usage, as shown in [Figure 2](#).

For more information on synchronization configuration options, see [GPS synchronization](#).

Figure 2: TDD frame division

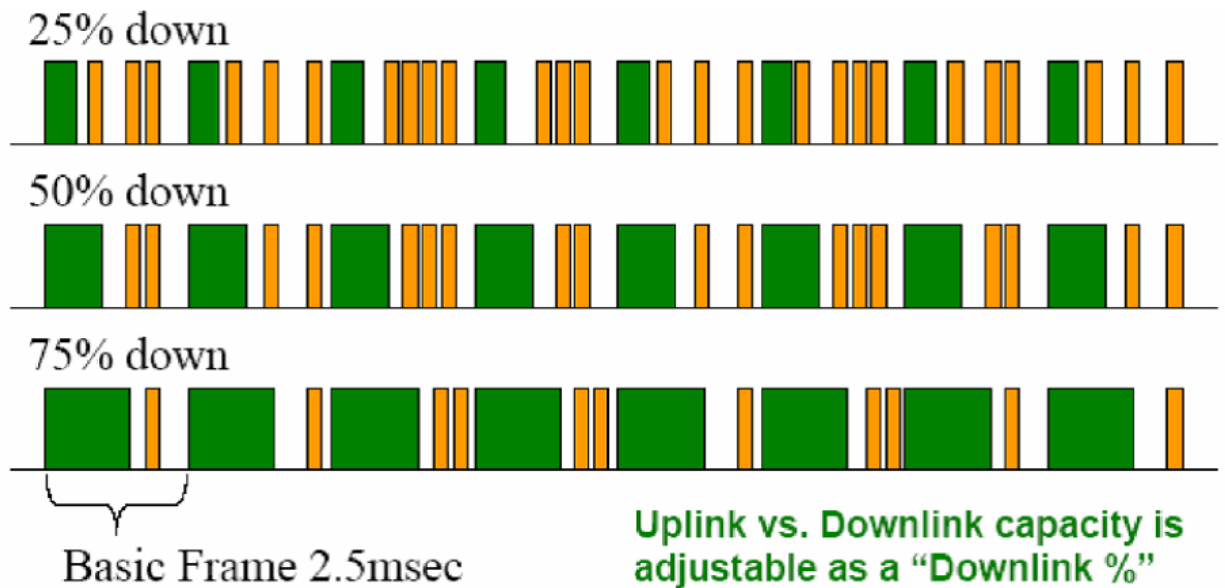

TDD frame parameters

The TDD burst duration varies depending on the following:

- Channel bandwidth
- Cyclic prefix (CP)
- Frame period
- Frame configuration - Downlink data
- Link operation – Dynamic rate adaptation

OFDM and Channel bandwidth

The PMP/PTP 450 Platform Family transmits using Orthogonal Frequency Division Multiplexing (OFDM). This wideband signal consists of many equally spaced subcarriers. Although each subcarrier is modulated at a low rate using conventional modulation schemes, the resultant data rate from the subcarriers is high. OFDM works exceptionally over a Non-Line-of-Sight (NLoS) channel.

The channel bandwidth of the OFDM signal is configurable to one of the following values: 5, 7, 10, 15, 20, 30, and 40 MHz. Higher bandwidths provide greater link capacity at the expense of using more bandwidth. Systems configured for a narrower channel bandwidth provide better receiver sensitivity and can also be an appropriate choice in deployments where the amount of free spectrum is limited.



Note

The channel bandwidth must be configured to the same value at both ends of the link. Not all channel bandwidths are available in all regulatory bands.

Cyclic prefix

OFDM technology uses a cyclic prefix, where a portion of the end of a symbol (slot) is repeated at the beginning of the symbol (slot) to allow multi-pathing to settle before receiving the desired data. A 1/16 cyclic prefix means that for every 16 bits of throughput data transmitted, an additional bit is used. The 450 Platform Family ODU's have been locked to a 1/16 CP.

Frame period

The frame period or frame duration is the time between the beginning of a frame and the end of the frame. The 450 Platform Family supports two frame periods: 2.5 ms and 5 ms.

The 5 ms frame period configuration provides higher throughput as a result of reduced frame overhead during transmission. In turn, the 2.5 ms frame period configuration affords reduced latency in the system, half of what is introduced by the 5 ms frame configuration.

Frame configuration - Downlink data

The percentage of frame assigned to transport downlink data. The downlink data specifies the percentage of the aggregate throughput for the downlink (frames transmitted from the AP/BHM to the subscriber). The configurable range is 15% to 85%.



Note

For all 450 platform APs, the maximum configurable range is 34% to 66% for 40 MHz with 5 ms frame.

Link operation – Dynamic rate adaption

The 450 Platform Family ODU's offer eight levels or speeds of operations:

- 2X MIMO-B and 1X MIMO-A (QPSK)
- 4X MIMO-B and 2X MIMO-A (16-QAM)
- 6x MIMO-B and 3X MIMO-A (64-QAM)
- 8X MIMO-B and 4X MIMO-A (256-QAM)

If received power varies due to distance between the AP/BHM and the SM/BHS or due to obstructions, or if interference affects the RF environment, the system dynamically adjusts the links to the best operation level.

The system chooses its modulation rate dynamically, based on an internal ARQ (Automatic Repeat reQuest) error control method. With ARQ, every data slot of every frame sent over the air (except downlink broadcast) is expected to be acknowledged by the receiver, and if acknowledgment is not received, the data is resent. The sending unit monitors these resends and adjusts the modulation rate accordingly. It is normal to have links that change levels of operation as the RF environment changes. Furthermore, the uplink or downlink portions of TDD duty cycle operate independently.

The various modulation levels used by 450 Platform Family are shown in [Table 19](#).

Table 19: Modulation levels

Rate	MIMO-B	MIMO-A
QPSK	2X MIMO-B	1X MIMO-A
16-QAM	4X MIMO-B	2X MIMO-A
64-QAM	6X MIMO-B	3X MIMO-A
256-QAM	8X MIMO-B	4X MIMO-A



Note

MIMO-A achieves half the throughput of MIMO-B but adds a combining diversity (gain) which enhances the link budget or availability.

Encryption

The 450 Platform Family supports optional encryption for data transmitted over the wireless link. The 450 Platform Family supports Advanced Encryption Standard 9(AES) for security of the wireless link.

AES is an over-the-air link encryption that uses the Rijndael algorithm, 128-bit key and 256-bit key size to establish a higher level of security. AES products are certified as compliant with the Federal Information Processing Standards (FIPS) 197 in the U.S.A.

The default setting on an AP is **Disabled**.

MIMO

MIMO techniques protect against fading and increase the probability that the receiver decodes a usable signal. When the effects of MIMO are combined with those of OFDM techniques and a high link budget,

there is a high probability of a robust connection over a NLoS.

The sub-features that comprise the MIMO techniques utilized in the 450 Platform Family ODUs are:

- MIMO-A: This technique enables 450 Platform Family radio to use a scheme that optimizes coverage by transmitting the same data over both antennas. This redundancy improves the signal-to-noise ratio (SNR) at the receiver making it more robust.
- MIMO-B: This technique provides the ability to double the throughput of a radio transmission under proper RF conditions. Different data streams are transmitted simultaneously on two different antennas.

MU-MIMO

MIMO is a range of technologies used to multiply the capacity of a wireless connection without requiring more spectrum.

Although traditional MIMO techniques are focused on increasing the bandwidth available between two wireless nodes, multi-user MIMO (MU-MIMO) applies these technologies to increase overall wireless network capacity by allowing an AP to communicate wirelessly with more than one wireless node at once.

An MU-MIMO access point features an array of antennas. When the AP decides to communicate with multiple nodes at the same time, it creates or receives multiple simultaneous beams between each node.

This is in contrast to a traditional wireless system, where two wireless nodes cannot communicate on the same channel to the same AP at the same time, without causing significant self-interference and degrading the overall wireless network performance.

An MU-MIMO access point estimates and measures what a transmission from each wireless node sounds like, by applying knowledge of the wireless path characteristics between the access point and the node. Known as channel estimation, this process is of vital importance; without it, the access point cannot distinguish properly between wireless nodes, affecting its performance.

Channel estimation is achieved at the access point in the downlink direction by sending a specific signal to a wireless node, which the node then reports back. The uplink channel estimates are made in a similar manner at the AP, by measuring the normal uplink communication to each node. These measurements between the AP and the nodes provide a measure of the wireless conditions and can be applied to other communications to/from the node and is known as channel sounding.

Channel estimation and sounding must be regularly repeated to ensure wireless network performance remains high. The speed at which a system can accurately estimate the channel has a large impact on performance.

Once channel estimation is completed for a wireless node, the MU-MIMO access point can electrically tune each antenna to provide the highest performance for that node. The AP uses beamforming to create a radio beam to that node which is tuned for optimum performance and avoids beams directed to other nodes, reducing interference and helping to improve overall wireless network capacity.

An MU-MIMO access point can communicate to multiple wireless nodes simultaneously using this process. As the majority of nodes are unable to make full use of the whole access point capacity at once,

communicating with several nodes simultaneously can greatly improve the overall capacity achieved in the wireless network.

System management

This section introduces the 450 Platform Family management system, including the web interface, installation, configuration, alerts, and upgrades.

Management agent

The 450 Platform Family radios are managed through an embedded management agent.

Management workstations, network management systems or PCs can be connected to this agent using the module's Ethernet port or over-the air (SM/BHS).

The management agent supports the following interfaces:

- Hypertext transfer protocol (HTTP)
- Hypertext transfer protocol secure (HTTPS)
- RADIUS authentication
- Simple network management protocol (SNMP) – v2c and v3
- Network time protocol (NTP)
- System logging (Syslog)
- Wireless Manager (WM) software
- Canopy Network Updater Tool (CNUT) software
- cnMaestro™

Web server

The 450 Platform Family management agent contains a web server. The web server supports access via the HTTP/HTTPS interface.

Web-based management offers a convenient way to manage the 450 Platform Family radios from a locally connected computer or a network management workstation connected through a management network, without requiring any special management software. The web and SNMP are the interfaces supported for installation of 450 Platform Family radios and for the majority of configuration management tasks.

Web pages

The web-based management interfaces provide comprehensive web-based fault, configuration, performance, and security management functions organized into the following groups:

Access Point or Backhaul Master:

- Home
- Configuration
- Statistics
- Tools
- Logs
- Accounts
- Quick Start
- Copyright

Subscriber Module or Backhaul Slave:

- Home
- Configuration
- Statistics
- Tools
- Logs
- Accounts
- PDA
- Copyright

Identity-based user accounts

TECHNICIAN, who has permission to modify basic radio parameters and view informational web pages

GUEST, who has no write permissions and only a limited view of the General Status tab

- Admin, Installer and Tech accounts can be configured as READ-ONLY. This allows the account to only see the items.
- When identity-based user accounts are configured, a security officer can define from one to four user accounts, each of which may have one of the four possible roles:
- ADMINISTRATOR, who has full read and write permissions. This is the level of the root and admin users, as well as any other administrator accounts that one of them creates.

- INSTALLER, who has permissions identical to those of ADMINISTRATOR except that the installer cannot add or delete users or change the password of any other user.
- See [Managing module access by passwords](#) for detailed information on account permissions.

Remote Authentication Dial-in User Service (RADIUS)

The PMP configuration of 450 Platform Family includes support for RADIUS (Remote Authentication Dial In User Service) protocol functionality including:

- **SM Authentication:** Allows only known SMs onto the network (blocking rogue SMs), and can be configured to ensure SMs are connecting to a known network (preventing SMs from connecting to rogue APs). RADIUS authentication is used for SMs, but not used for APs.
- **SM Configuration:** Configures authenticated SMs with MIR (Maximum Information Rate), high priority, and VLAN (Virtual LAN) parameters from the RADIUS server when an SM registers to an AP.
- **User authentication** allows users to configure a separate user authentication server along with the SM authentication server. If firmware is upgraded while using this functionality and no user authentication servers are configured, then AP continues to use the SM authentication server for user authentication.
- **SM accounting** provides support for RADIUS accounting messages for usage-based billing. This accounting includes indications for subscriber session establishment, subscriber session disconnection, and bandwidth usage per session for each SM that connects to the AP.
- **Centralized AP and SM user name and password management:** Allows AP and SM usernames and access levels (Administrator, Installer, Technician, and Read-Only) to be centrally administered in the RADIUS server instead of on each radio and tracks access events (logon/logoff) for each username on the RADIUS server. This accounting does not track and report specific configuration actions performed on radios or pull statistics such as bit counts from the radios. Such functions require an Element Management System (EMS) such as Cambium Wireless Manager. This accounting is not the ability to perform accounting functions on the subscriber/end user/customer account.
- **Framed-IP-Address:** Operators may use a RADIUS server to assign management IP addressing to SM modules.
- **SNMP**

The management agent supports fault and performance management using an SNMP interface. The management agent is compatible with SNMP v2c and SNMP v3 using Management Information Base (MIB) files which are available for download from the Cambium Networks Support website:

- <https://support.cambiumnetworks.com/files/ptp450>
- <https://support.cambiumnetworks.com/files/pmp450>

Network Time Protocol (NTP)

The clock supplies accurate date and time information to the system. It can be set to run with or without a connection to a network time server. It can be configured to display local time by setting the time zone and daylight saving in the **Time web page**.

If an NTP server connection is available, the clock can be set to synchronize with the server time at regular intervals. The 450 Platform Family radios may receive NTP data from a CMM4/CMM5 module or an NTP server configured in the system's management network.

The **Time Zone** option is configurable on the AP's/BHM's **Time Configuration** page, and may be used to offset the received NTP time to match the operator's local time zone. When set on the AP/BHM, the offset is set for the entire sector (AP/BHSs are notified of the current time zone upon initial registration). If a time zone change is applied, the AP/BHSs are notified of the change in a best effort fashion, meaning some AP/BHSs may not pick up the change until the next re-registration. Time zone changes are noted in the **Event Log** page.

An AP/BHM that is receiving NTP date and time information from an NTP server or from a GPS synchronization source may be used as an NTP server. Any client which has IP connectivity to the BHM may request NTP date and time information from the AP/BHM. No additional configuration (other than the AP/BHM receiving valid NTP data) is required to use the AP/BHM as an NTP server.

Starting in Q1 2025, all PMP AP/BHMs must have an accurate clock setting to ensure successful connectivity to cnMaestro Cloud.

cnMaestro™

cnMaestro™ is a cloud-based or on-premises platform specialized for secure, end-to-end network lifecycle management, which includes inventory management, device onboarding, daily operations, and maintenance. cnMaestro™ is recommended for managing 450 Platform Family networks. The cnMaestro™ wireless network manager simplifies device management by offering full network visibility. Network operators can have a real-time view of their complete end-to-end network and perform a full suite of wireless network management functions to optimize system availability, maximize throughput, and meet emerging needs of business and residential customers. In addition, the cnMaestro™ wireless network manager collects and displays compliance with service level agreements.

To learn about cnMaestro™, please visit <http://www.cambiumnetworks.com/products/software-tools/cnmaestro/>.

Canopy Network Updater Tool (CNUT)

CNUT (Canopy Network Updater Tool) is the standalone software update tool for 450 Platform Family ODUs. The CNUT 4.11.2 must be used for 450 Platform Family ODUs.

The Canopy Network Updater Tool has the following features:

- Automatically discovers all network elements
- HTTP and HTTPS protocol support

- Executes UDP command that initiates and terminates the auto-update mode within APs/BHMs. This command is both secure and convenient:
 - For security, the AP/BHM accepts this command from only the IP address specified in the **Configuration** page of ODU.
 - For convenience, **Network Updater** automatically sets this configuration parameter in the AP/BHM to the IP address of the network updater server when the server performs any of the update commands.
- Allows you to choose the following option while updating:
 - Entire network
 - Only selected elements
 - Only selected network branches
- Provides a script engine that you can use with any script which:
 - The user can define.
 - Cambium Networks supplies.

CNUT is available at:

<https://www.cambiumnetworks.com/products/management/cambium-network-updater-tool/>

CNUT is not supported on any 450v PMP radios. These radios must be upgraded either through cnMaestro or directly from the **Tools > Firmware Upgrade** page on the radio.

Radio recovery mode

The 450 Platform Family radio recovery mode provides a means to recover from serious configuration errors including lost or forgotten passwords and unknown IP addresses.

The recovery procedure for 450m/450i/450b/450v series and 450 series ODUs differ due to differences in hardware. This procedure for 450i/450m Series is known as Radio Recovery Console and for 450 Series is known as Default Mode (or Default/Override Plug). MicroPoP Omni/Sector/Connectorized series supports an external Reset push button for recovery.

Radio Recovery Console – 450i, 450b 450m, 450v, MicroPoP, and Retro Series

The Radio Recovery Console mode supports:

- Restoring factory default IP address 169.254.1.1 and password
- Boot with factory default Canopy system software settings

- Load previously installed software images

Refer the **Radio Recovery Console-PMP/PTP 450i/450b/450v** and **PMP 450m** topic in the *Configuration Guide* for more details.

Default Mode (or Default Plug) – 450 Series

A default plug is available to provide access to a module whose password and/or IP address have been forgotten.

This plug allows the 450 Series ODUs to be accessed using IP address 169.254.1.1 and no password. During the override session, you can assign any new IP address and set either or both user passwords (display-only and/or full access) as well as make other parameter changes.

Refer the **Default Mode (or Default/Override Plug) – PMP/PTP** topic in the *Configuration Guide* for more details.

Chapter 2: System hardware

This chapter describes the hardware components of a 450 Platform family series.

The chapter covers the following topics:

- [System components](#)
- [450 Platform family ODU interfaces](#)
- [Power supply options](#)
- [ODU mounting brackets and accessories](#)
- [Lightning protection](#)
- [Cabling](#)
- [Lightning protection unit \(LPU\) and grounding kit](#)
- [Antennas and antenna cabling](#)
- [GPS synchronization](#)
- [Installing a GPS receiver](#)
- [Ordering the components](#)

System components

The System components section describes the following key elements:

PMP

The PMP radio is a transceiver device. It is a Connectorized or radiated outdoor unit containing all the radio, networking, and surge suppression electronics. It can be purchased as:

- AP
- SM

PMP 450 Platform family Integrated or Connectorized ODU

The PMP 450i Series, PMP 450b Series, PMP 450 MicroPoP Series, and PMP 450 Series ODUs are available in integrated or Connectorized configurations. The PMP 450m Series AP and PMP 450v Series AP and SM are supplied in an integrated configuration only.

- See [PMP 450m Series hardware configurations](#)
- See [PMP/PTP 450i Series hardware configurations](#)
- See [PMP/PTP 450b Series hardware configurations](#)
- See [PMP/PTP 450 Series hardware configurations](#)
- See [PMP 450 MicroPoP Series hardware configurations](#)
- See [PMP/PTP 450b Retro Series hardware configurations](#)
- See [PMP/PTP 450b Connectorized series hardware configurations](#)
- See [450v Series hardware configuration](#)

Product variants

Table 20: PMP 450m Series variants

Variant	Region	Antenna	Frequency Range	Channel Bandwidth	Maximum EIRP
5 GHz PMP 450m AP	FCC	90° integrated sector array, 14x14 MIMO system,	5150 – 5925 MHz	5, 10, 15, 20, 30, 40 MHz	48 dBm
	RoW				
	EU				
	IC				
	No Encryption				
3 GHz PMP 450m AP	Global	90° integrated sector array, 8x8 MIMO system,	3450 – 3980 MHz	5, 7, 10, 15, 20, 30, 40 MHz	58 dBm
	Global (No Encryption)				

Table 21: PMP 450i Series variants

Variant	Region	Antenna	Frequency Range	Channel Bandwidth	Max Tx Power
900 MHz PMP 450i AP	FCC	Connectorized	902 - 928 MHz	5, 7, 10, 15, 20 MHz	25 dBm
3 GHz PMP 450i AP	All, No Encryption	Connectorized	3300 – 3900 MHz	5, 7, 10, 15, 20, 30, 40 MHz	25 dBm
		Integrated 16 dBi			
5 GHz PMP 450i AP	FCC, IC, EU, RoW, and No Encryption	Connectorized	4900 – 5925 MHz	5, 10, 15, 20, 30, 40 MHz	27 dBm
		Integrated 16 dBi 90 degree			

Table 22: PMP/PTP 450b Series variants

Frequency Variant	Variant	Antenna	Frequency Range	Channel Bandwidth	Max Tx Power
3 GHz 450b	High Gain	20 dBi dish	3450 – 3980 MHz	5, 7, 10, 15, 20, 30, 40 MHz	29 dBm

Frequency Variant	Variant	Antenna	Frequency Range	Channel Bandwidth	Max Tx Power
5 GHz 450b	Mid-Gain	16 dBi integrated antenna	4900 – 5925 MHz	5, 10, 15, 20, 30, 40 MHz	27 dBm
	High Gain	24 dBi dish			
5/6 GHz 450b	High Gain	24 dBi dish	5725 - 6300 MHz	5, 10, 15, 20, 30, 40 MHz	27 dBm



Note

Some region, product, and frequency combinations require operators to limit transmit power to comply with regulatory restrictions. See Chapter 4: **Reference Information** in the PMP 450 Series *Configuration Guide* for details.

Table 23: PMP 450 MicroPoP Series variants

Frequency Variant	Region	Antenna	Frequency Range	Channel Bandwidth	Maximum Tx Power
5 GHz PMP 450 MicroPoP Omni AP	FCC, RoW, Canada, RoW no encryption, Europe	9 dBi integrated	4900-5925 MHz	5, 10, 15, 20, 30, 40 MHz	27 dBm
5 GHz PMP 450 MicroPoP Sector AP		13 dBi integrated	4900-5925 MHz	5, 10, 15, 20, 30, 40 MHz	27 dBm
5 GHz PMP 450 MicroPoP Connectorized AP		External antenna	4900-5925 MHz	5, 10, 15, 20, 30, 40 MHz	27 dBm

Table 24: PMP 450b Retro Series variants

Frequency Variant	Region	Antenna	Frequency Range	Channel Bandwidth	Maximum Tx Power
5 GHz 450b Retro SM	FCC, RoW, Canada, RoW no encryption, Europe	8 dBi integrated	4900-5925 MHz	5, 10, 15, 20, 30, 40 MHz	27 dBm

Table 25: 5 GHz PMP 450b Connectorized SM variants

Frequency Variant	Region	Antenna	Frequency Range	Channel Bandwidth	Maximum Tx Power
5 GHz 450b Connectorized SM	FCC, RoW, Canada, RoW no encryption, Europe	External antenna	4900-5925 MHz	5, 10, 15, 20, 30, 40 MHz	27 dBm



Note

Some region, product, and frequency combinations require operators to limit transmit power to comply with regulatory restrictions. See Chapter 4: **Reference Information** in the PMP 450 Series *Configuration Guide* for details.

Table 26: PMP 450 Series variants

Variant	Region	Antenna	Frequency Range	Channel Bandwidth	Maximum Tx Power
900 MHz PMP 450 SM	FCC	Connectorized	902 - 928 MHz	5, 7, 10, 15, 20 MHz	25 dBm
2.4 GHz PMP 450 AP	FCC ISM	Connectorized	2400 – 2483.5 MHz	5, 10, 15, 20 MHz	22 dBm
		Integrated 18 dBi			
2.4 GHz PMP 450 SM	FCC ISM	Connectorized	2400 – 2483.5 MHz	5, 10, 15, 20 MHz	22 dBm
		Integrated 7 dBi			
3.5 GHz PMP 450 AP	FCC ISM	Connectorized	3300 – 3600 MHz	5, 7, 10, 15, 20, 30, 40 MHz	25 dBm
		Integrated 16 dBi			
3.5 GHz PMP 450 SM	FCC ISM	Connectorized	3300 – 3600 MHz	5, 7, 10, 15, 20, 30, 40 MHz	25 dBm
		Integrated 8 dBi			
		Integrated 19 dBi			
3.65 GHz PMP 450 AP	FCC ISM	Connectorized	3500 – 3850 MHz	5, 7, 10, 15, 20, 30, 40 MHz	25 dBm
		Integrated 16 dBi			
3.65 GHz PMP 450 SM	FCC ISM	Connectorized	3500 – 3850 MHz	5, 7, 10, 15, 20, 30, 40 MHz	25 dBm
		Integrated 8 dBi			
		Integrated 19 dBi			
5.4/5.8 GHz PMP 450 AP	FCC, RoW, RoW DES	Connectorized	5470 – 5875 MHz	5, 10, 15, 20, 30, and 40 MHz (5, 15 and 30 MHz are not available in DFS regions)	22 dBm
		Integrated 17 dBi			

Variant	Region	Antenna	Frequency Range	Channel Bandwidth	Maximum Tx Power
5.4/5.8 GHz PMP 450 SM	FCC, ROW, RoW DES	Connectorized	5470 – 5875 MHz	5, 10, 15, 20, 30, and 40 MHz (5, 15 and 30 MHz are not available in DFS regions)	22 dBm
		Integrated 9 dBi			
		Integrated 25 dBi			



Note
Some region, product, and frequency combinations require operators to limit transmit power to comply with regulatory restrictions. See Chapter 4: **Reference Information** in the PMP 450 Series *Configuration Guide* for details.

Table 27: 450v Series variants

Variant	Region	Antenna	Frequency Range	Channel Bandwidth	Maximum Tx Power
5/6 GHz 450v AP Integrated (4x4) Sector Antenna	FCC, and IC	Integrated	5.125 GHz – 7.125 GHz	5, 10, 15, 20, 30, 40 MHz	28 dBm (for 5 GHz) 20 dBm (for 6 GHz)
5/6 GHz 450v SM Integrated (4x4) Antenna	FCC, and IC	Integrated	5.125 GHz – 7.125 GHz	5, 10, 15, 20, 30, 40 MHz	28 dBm (for 5 GHz) 20 dBm (for 6 GHz)
5/6 GHz 450v SM Integrated (2x2) Antenna	FCC, and IC	Integrated	5.125 GHz – 7.125 GHz	5, 10, 15, 20, 30, 40 MHz	28 dBm (for 5 GHz) 20 dBm (for 6 GHz)
5/6 GHz 450b6 SM Integrated Antenna	FCC, and IC	Integrated	5.725 GHz – 6.300 GHz	5, 10, 15, 20, 30, 40 MHz	27 dBm (for 5 GHz) 20 dBm (for 6 GHz)

Backhaul (PTP)

The backhaul radio is a transceiver device. It is a Connectorized or integrated outdoor unit containing all the radio, networking, and surge suppression electronics. It can be configured as:

- Backhaul Master (BHM)
- Backhaul Slave (BHS)

PTP 450 Platform family integrated or Connectorized ODU

- See [PMP/PTP 450i Series hardware configurations](#)
- See [PMP/PTP 450b Series hardware configurations](#)
- See [PMP/PTP 450 Series hardware configurations](#)
- See [PMP/PTP 450b Retro Series hardware configurations](#)
- See [PMP/PTP 450b Connectorized series hardware configurations](#)
- See [PMP/PTP 450v series hardware configurations](#)

Product variants

Table 28: PTP 450i Series variants

Variant	Region	Antenna	Frequency Range	Channel Bandwidth	Maximum Tx Power
3 GHz PTP 450i	FCC, RoW, Canada, Row DES, Europe	Connectorized	3300 - 3900 MHz	5, 7, 10, 15, 20, 30, 40 MHz	25 dBm
		Integrated 23 dBi			
5 GHz PTP 450i	FCC, RoW, Canada, Row DES, Europe	Connectorized	4900 – 5925 MHz	5, 10, 15, 20, 30, 40 MHz	27 dBm
		Integrated 23 dBi			



Note

Some region, product, and frequency combinations require operators to limit transmit power to comply with regulatory restrictions. See Chapter 4: **Reference Information** in the PMP 450 Series *Configuration Guide* for details.

Table 29: PTP 450b Series variants

Variant	Region	Antenna	Frequency Range	Channel Bandwidth	Maximum Tx Power
3 GHz PTP 450b	FCC, RoW, Canada, Row DES, and Europe	20 dBi Dish antenna	3300 - 3900 MHz	5, 7, 10, 15, 20, 30, 40 MHz	29 dBm

Variant	Region	Antenna	Frequency Range	Channel Bandwidth	Maximum Tx Power
5 GHz PTP 450b	FCC, RoW, Canada, Row DES, Europe	Integrated 16 dBi	4900 – 5925 MHz	5, 10, 15, 20, 30, 40 MHz	27 dBm
		24 dBi Dish antenna			
5/6 GHz PTP 450b	RoW, and Row DES	24 dBi Dish antenna	5725 - 6300 MHz	5, 10, 15, 20, 30, 40 MHz	27 dBm



Note

Some region, product, and frequency combinations require operators to limit transmit power to comply with regulatory restrictions. See Chapter 4: **Reference Information** in the PMP 450 Series *Configuration Guide* for details.

Table 30: PTP 450 Series variants

Variant	Region	Antenna	Frequency Range	Channel Bandwidth	Maximum Tx Power
900 MHz PTP 450 BH	FCC	Connectorized	902 – 928 MHz	5, 7, 10, 15, 20 MHz	25 dBm
3.5 GHz PTP 450 BH	ROW	Connectorized	3300 – 3600 MHz	5, 7, 10, 15, 20, 30, 40 MHz	25 dBm
		Integrated 16 dBi			
		Integrated 19 dBi			
3.65 GHz PTP 450 BH	ROW	Connectorized	3500 – 3850 MHz	5, 7, 10, 15, 20, 30, 40 MHz	25 dBm
		Integrated 16 dBi			
		Integrated 19 dBi			
5.4/5.8 GHz PTP 450 BH	FCC, RoW, RoW DES	Connectorized	5470 – 5875 MHz	5, 10, 15, 20, 30, 40 MHz	22 dBm
		Integrated 9 dBi			
		Integrated 25 dBi			



Note

Some region, product, and frequency combinations require operators to limit transmit power to comply with regulatory restrictions. See Chapter 4: **Reference Information** in the PMP 450 Series *Configuration Guide* for details.

Table 31: PTP 450b Retro Series variants

Variant	Region	Antenna	Frequency Range	Channel Bandwidth	Maximum Tx Power
5 GHz PTP 450b Retro BH	FCC, RoW, Canada, RoW no encryption, Europe	Integrated 8 dBi	4900-5925 MHz	5, 10, 15, 20, 30, 40 MHz	27 dBm

Table 32: 5 GHz PTP 450b Connectorized BH variants

Frequency Variant	Region	Antenna	Frequency Range	Channel Bandwidth	Maximum Tx Power
5 GHz PTP 450b Connectorized BH	FCC, RoW, Canada, RoW no encryption, Europe	External antenna	4900-5925 MHz	5, 10, 15, 20, 30, 40 MHz	27 dBm

Table 33: 5/6 GHz PTP 450v BH variants

Frequency Variant	Region	Antenna	Frequency Range	Channel Bandwidth	Maximum Tx Power
5/6 GHz 450v BHM/BHS (4x4)	FCC, and IC	Integrated 4x4 Antenna	Integrated	5, 10, 15, 20, 30, 40 MHz	28 dBm (for 5 GHz) 20 dBm (for 6 GHz)
5/6 GHz 450v BHM/BHS (2x2)	FCC, and IC	Integrated 2x2 Antenna	Integrated	5, 10, 15, 20, 30, 40 MHz	28 dBm (for 5 GHz) 20 dBm (for 6 GHz)

450 Platform family ODU interfaces

PMP 450m Series interfaces AP – 3 GHz

The 3 GHz 450m Series AP interfaces are illustrated in [Figure 3](#).

Figure 3: 3 GHz PMP 450m Series interfaces

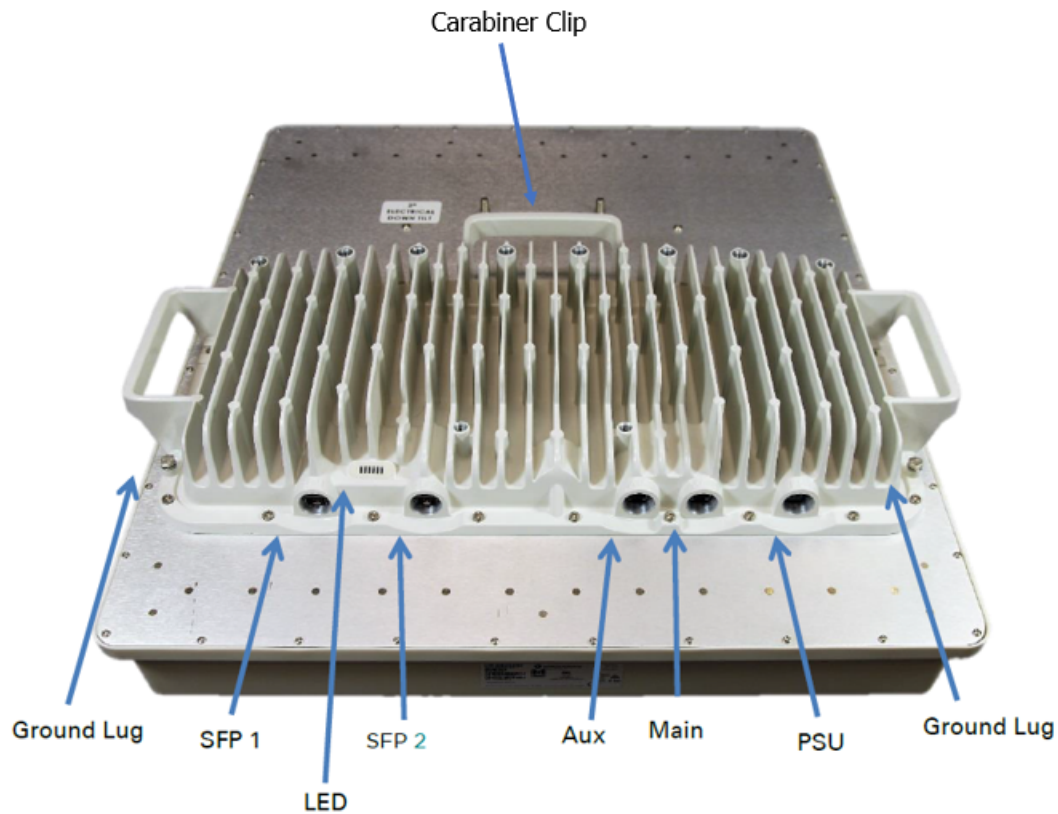

Table 34: PMP 3 GHz 450m Series AP interface descriptions and cabling

Interface	Function	Connector/Cabling
PSU	The device supports DC power input within the range of 40 to 60 V and is planned to include future support for Cambium Sync-over-power.	4 pin/4 core (2 twisted pairs)
MAIN	10/100/1000BASE-T Ethernet, plus Cambium Sync-over-data	RJ45/Cat 5e
AUX	10/100BASE-T Ethernet with PoE out	RJ45/custom Cat 5e
	The device features GPS synchronization input and output, as well as UGPS/cnPulse power output capabilities.	

Interface	Function	Connector/Cabling
SFP 1	The device accepts SFP modules; however, they are currently not utilized by the software.	Fiber or copper
SFP 2	The device accepts SFP modules (single or dual). The SFP port can be used as an alternative to the main Ethernet port on the 3 GHz 450m AP.	
Ground Lugs	Unit chassis ground. Refer to the <i>Installation Instructions</i> for more information.	10 AWG copper wire

PMP 450m Series interfaces AP - 5 GHz

The 5 GHz 450m Series AP interfaces are illustrated in [Figure 4](#).

Figure 4: 5 GHz PMP 450m Series interfaces

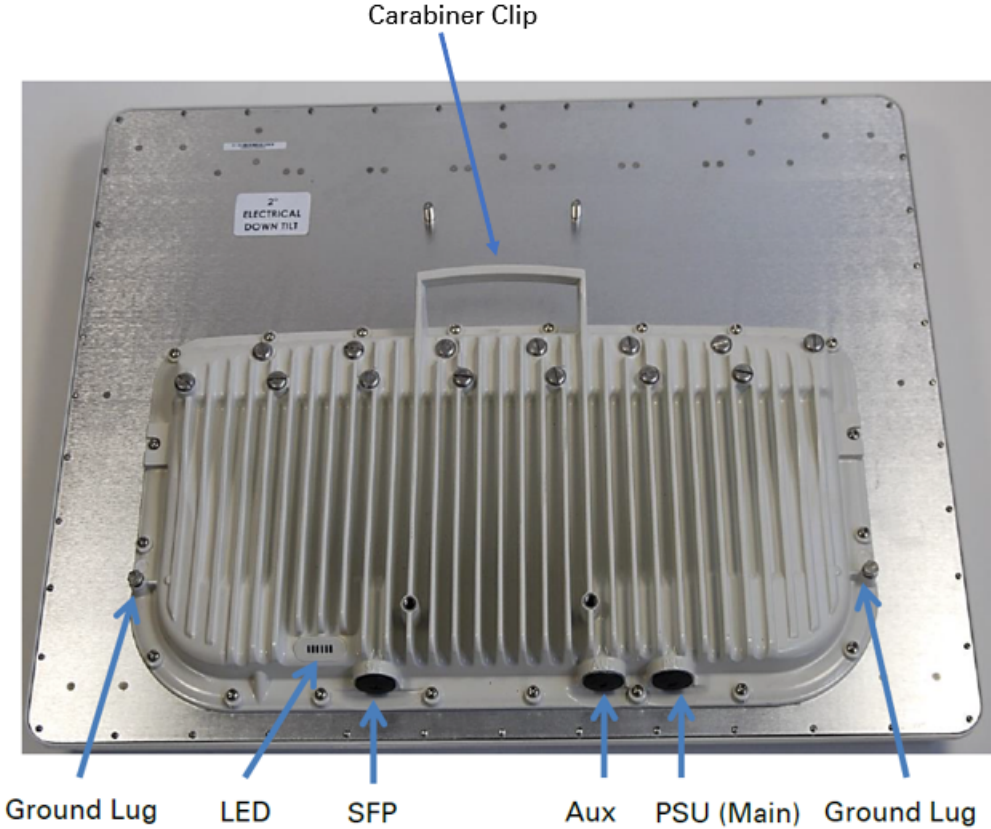

Table 35: PMP 5 GHz 450m Series AP interface descriptions and cabling

Interface	Function	Connector/Cabling
PSU	The device supports PoE with a range of 40-60 V DC, 10/100/1000BASE-T Ethernet, and also includes Cambium Sync-over-power capability.	RJ45/Cat 5e
AUX	10/100BASE-T Ethernet with PoE out	RJ45/custom Cat 5e
	The device offers GPS synchronization input and output capabilities, as well as UGPS/cnPulse power output.	
SFP	The device is equipped with an SFP port that accepts SFP modules. This SFP port can serve as an alternative to the MAIN Ethernet port on the 5 GHz 450m AP.	Fiber or copper
Ground Lugs	Unit chassis ground. Refer to the <i>Installation Instructions</i> for more information.	10 AWG copper wire



Note

- For the PMP 450m AP, Sync-Over-Power is exclusively supported with the CMM5.
- For the PMP 450m AP, Sync-Over-Power does not function with CMM4/CMM5, unlike the PMP 450/450i Series.
- SFP kits are required for SFP port connectivity. These kits include the following options:
 - Single Mode Optical SFP Interface per ODU (part number C000065L008A)
 - Multi-mode Optical SFP Interface per ODU (part number C000065L009A)
 - 2.5GBASE-T Copper SFP Interface per ODU (part number C000065L011A)

PMP/PTP 450b/450b6 High Gain Series Interfaces - SM/BHS

The AP/SM/BH interfaces are illustrated in [Figure 5](#).

Figure 5: PMP/PTP 450i interfaces

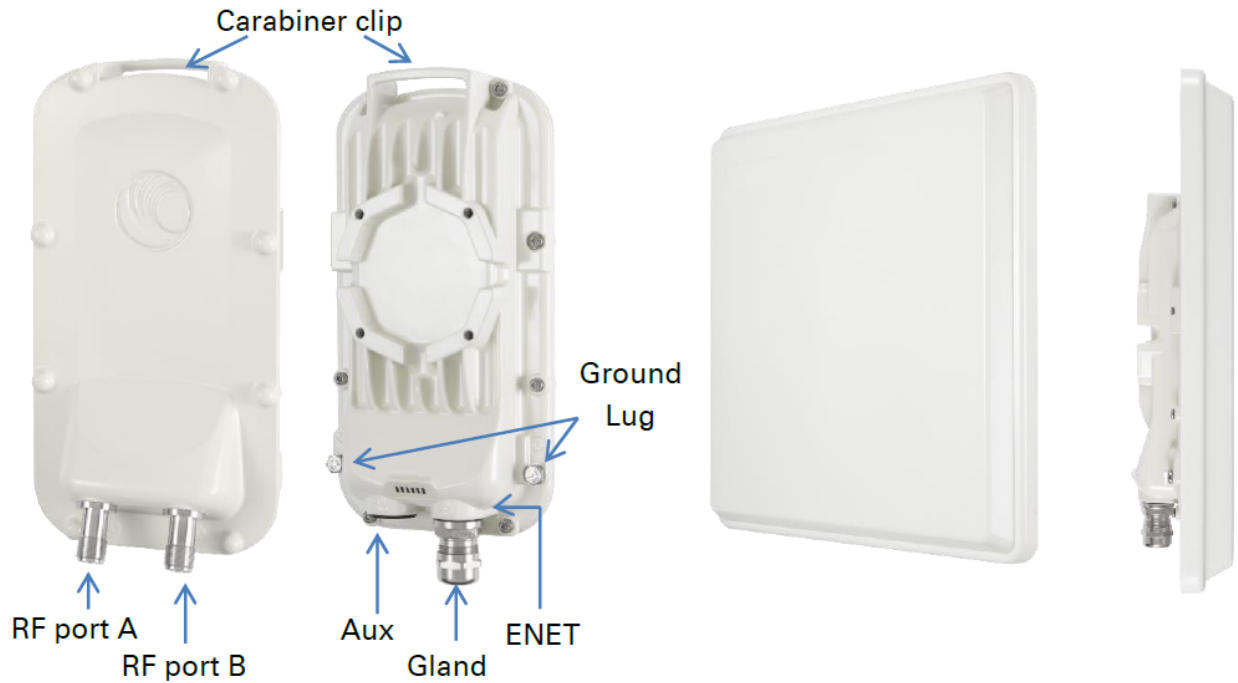

Table 36: PMP/PTP 450i Series - AP/SM/BH interface descriptions and cabling

Interface	Function	Connector/Cabling
PSU	The device supports PoE with a range of 48-59 V DC and is 802.3at compatible. It also features 10/100/1000BASE-T Ethernet, along with Cambium/Canopy Sync-over-power capability.	RJ45/Cat 5e
AUX	10/100BASE-T Ethernet with PoE out.	RJ45/custom Cat 5e
	The device offers both GPS synchronization input and output, as well as UGPS/cnPulse power output.	
	Alignment tone audio output.	
RF Port A	A vertically polarized RF connection is made to the antenna.	N-type/50 Ω coaxial
RF Port B	A horizontally polarized RF connection is made to the antenna.	N-type/50 Ω coaxial
Ground Lugs	Unit chassis ground. Refer to the <i>Installation Instructions</i> for more information.	10 AWG copper wire



Note

If the Aux port is used, a second Ethernet Gland needs to be ordered (Part Number: N000065L033A).



Warning

The PMP 450 Ruggedized High Gain integrated SM (Cambium part numbers CO35045CO14A and CO36045CO14A), when encapsulated in a 450i-type enclosure, contains 450 circuitry that requires 30 V DC power. Powering these SMs with a 56 V DC supply damages the device.

PMP/PTP 450b Mid-Gain Series interfaces - SM/BH

The PMP/PTP 450b Series - SM/BH interfaces are illustrated in below [Figure 6](#).

Figure 6: PMP 450b Mid-Gain Series interfaces

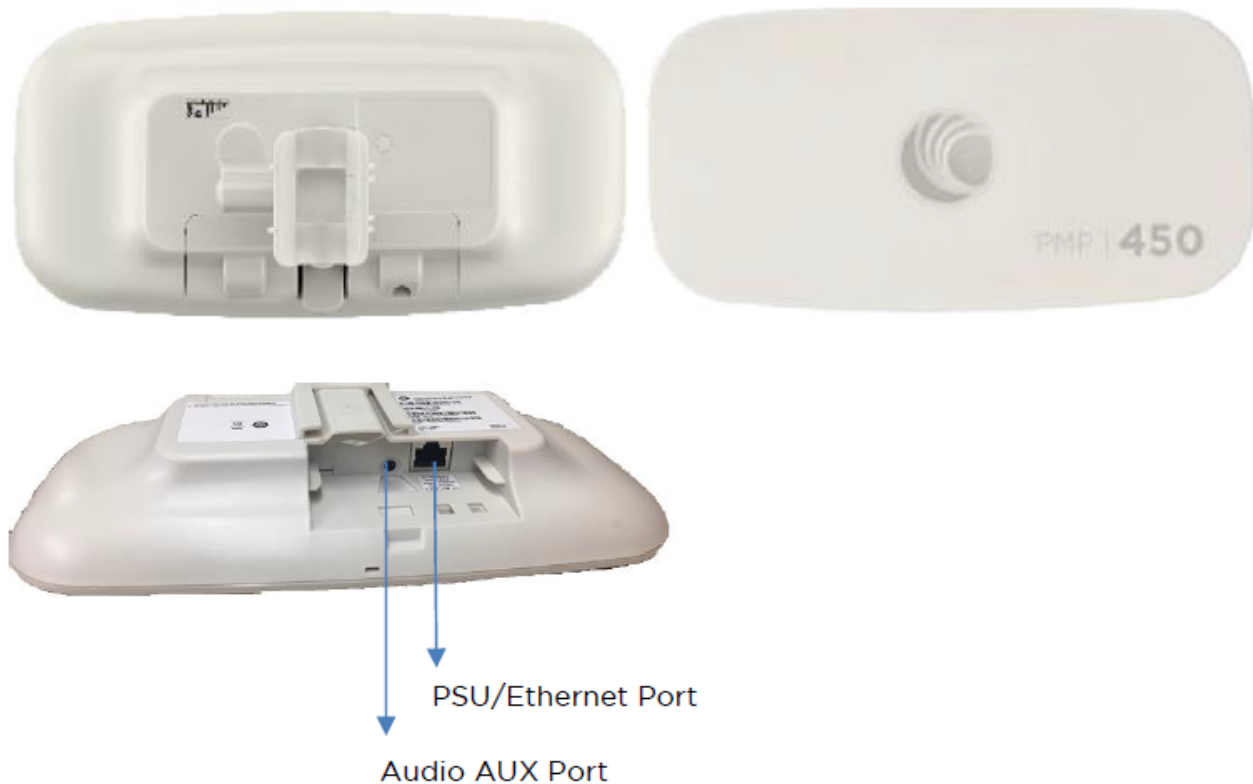

Table 37: PMP/PTP 450b Series - SM/BH (Mid-Gain) interface descriptions and cabling

Interface	Function	Connector/Cabling
Main/Power Port	The Canopy-style PoE supports a voltage range of 20-32 V DC and provides 10/100/1000BASE-T Ethernet connectivity. It also includes Canopy Sync-over-power functionality.	RJ45/Cat 5e
Aux Port	The device features GPS synchronization input and output, UGPS/cnPulse power output, and alignment tone audio output.	3.5 mm TRRS audio/standard headphones or custom sync cable

PMP/PTP 450b/450b6 High Gain Series Interfaces - SM/BHS

The 450b Series products are illustrated in [Figure 7](#) and [Figure 8](#). The interfaces are accessible from the rear of the dish and are located under the cover as shown.

Figure 7: 5 GHz 450b Series interfaces (High Gain)

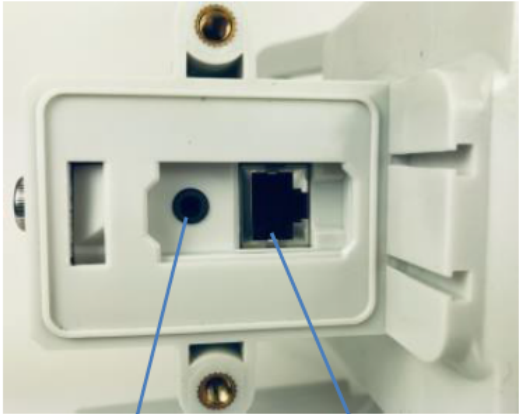

AUX Port PSU /
Ethernet Port

Figure 8: 3 GHz 450b Series interfaces (High Gain)



AUX Port PSU /
Ethernet Port

Table 38: PMP/PTP 450b Series (High Gain) SM/BH interface descriptions and cabling

Interface	Function	Connector/Cabling
Main/Power Port	The Canopy-style PoE supports a voltage range of 20-32 V DC and provides 10/100/1000BASE-T Ethernet, along with Canopy Sync-over-power.	RJ45/Cat 5e
Aux Port	The device features GPS synchronization input and output, UGPS/cnPulse power output, and alignment tone audio output.	3.5 mm TRRS audio/standard headphones or custom sync cable

PMP/PTP 450b Retro SM/BH interfaces

The PMP/PTP 450b Retro interfaces are illustrated in [Figure 9](#).

Figure 9: PMP/PTP 450b Retro SM/BH interface

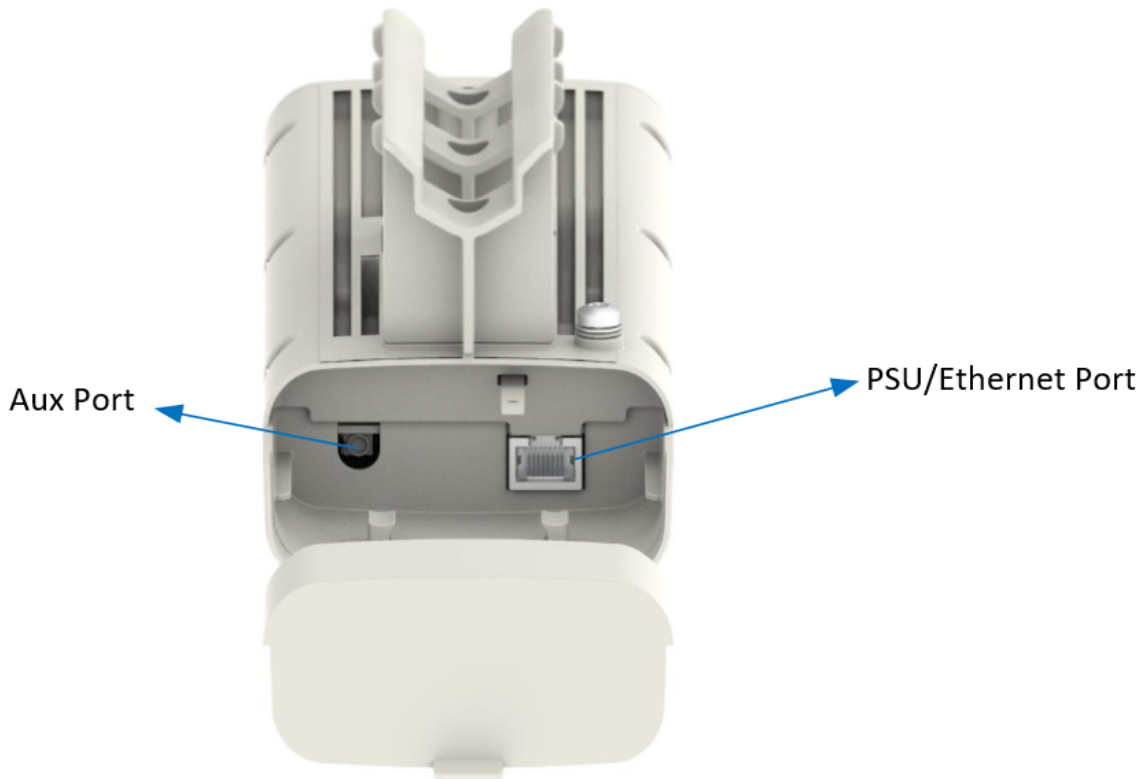

Table 39: PMP/PTP 450b Retro SM/BH interface descriptions and cabling

Interface	Function	Connector/Cabling
Main/Power Port	Canopy-style PoE supports a voltage range of 20-32 V DC, 10/100/1000BASE-T Ethernet, plus Canopy Sync-over-power.	RJ45/Cat 5e
Aux Port	The device supports GPS synchronization input and output, UGPS/cnPulse power output, and alignment tone audio output.	3.5 mm TRRS audio/standard headphones or custom sync cable
Ground Lugs	Unit chassis ground. Refer to the <i>Installation Instructions</i> for more information	10 AWG copper wire

PMP/PTP 450b Connectorized Interfaces - SM/BH

The PMP 450b Connectorized SM/BH interfaces are illustrated in [Figure 10](#)

Figure 10: PMP 450b Connectorized interfaces

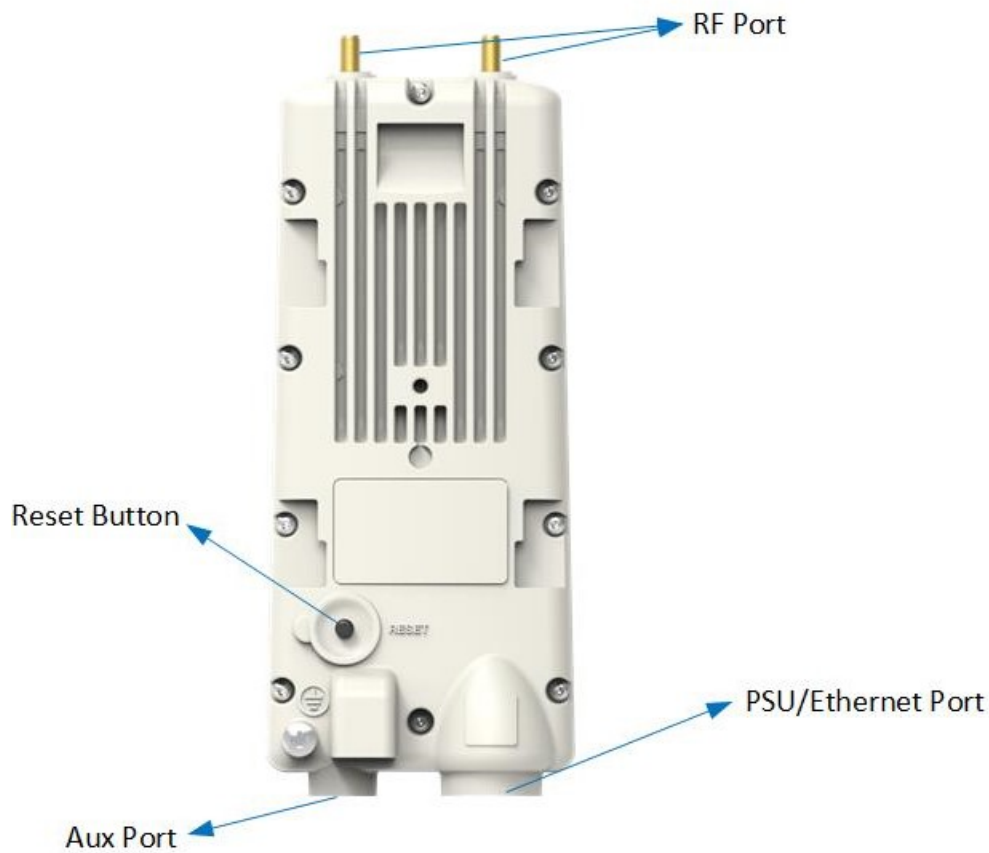

Table 40: PMP 450b Connectorized - SM/BH interface descriptions and cabling

Interface	Function	Connector/Cabling
Main/Power Port	The Canopy-style PoE supports 20-32 V DC, 10/100/1000BASE-T Ethernet, and includes Canopy Sync-over-power functionality.	RJ45/Cat 5e
Aux Port	The device features GPS synchronization input and output, UGPS/cnPulse power output, and alignment tone audio output.	3.5 mm TRRS audio/standard headphones or custom sync cable
RF Ports	The SM/BH antenna supports both horizontally and vertically polarized RF connections.	Reverse polarity SMA/50 Ω coaxial
Ground Lugs	Unit chassis ground. Refer to the <i>Installation Instructions</i> for more information	10 AWG copper wire

Note 1: GUI option **Sync Aux Port Configuration** controls the behavior of the Aux port.

Note 2: Pin-out detail for Aux port:

Tip:	Alignment Tone (Default) / GPS Sync 1PPS IN (cnPulse) or GPS Sync 1PPS Out (Remote AP).
Ring 1:	cnPulse +5 V Power Out / Alignment Tone Stereo Out.
Ring 2:	cnPulse Serial Data In.
Sleeve:	Ground

PMP/PTP 450 Series interfaces - AP

The PMP 450 Series - AP interfaces are illustrated in [Figure 11](#).

[Figure 11: PMP/PTP 450 Series - AP interfaces](#)

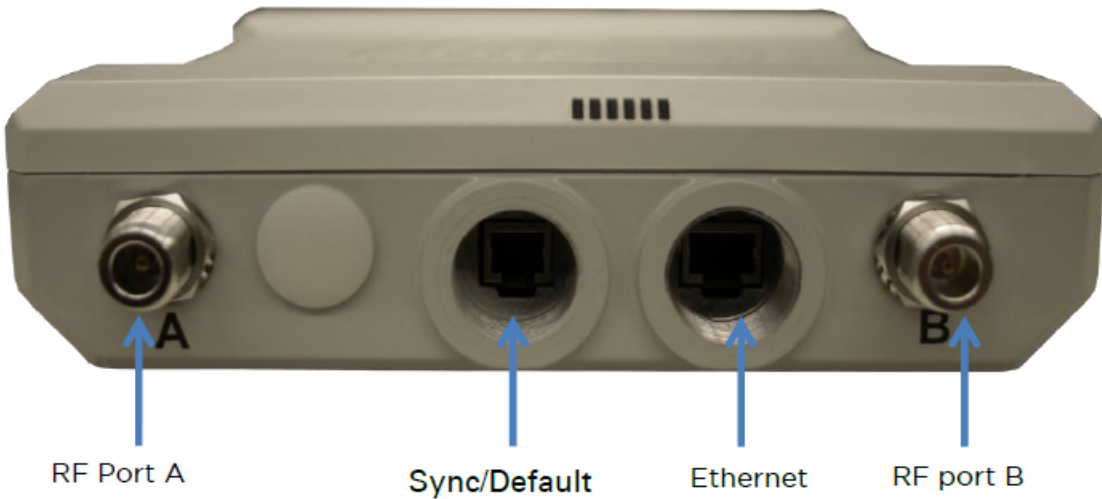

Table 41: PMP/PTP 450 Series - AP interface descriptions and cabling – 2.4 GHz and 5 GHz

Interface	Band	Function	Connector/Cabling
Main/Power Port		The Canopy-style PoE supports 22-32 V DC, 10/100/1000BASE-T Ethernet, and includes Canopy Sync-over-power functionality.	RJ45/Cat 5e
Aux Port		The device provides GPS synchronization input and output, UGPS/cnPulse power output, and a default plug port.	RJ12/custom Cat 5e
RF Port A	2.4 GHz, 3 GHz	The AP antenna supports a -45 degree polarized RF connection	N-type/50 Ω coaxial
	5 GHz	The AP antenna supports a vertically polarized RF connection	
RF Port B	2.4 GHz, 3 GHz	The AP antenna supports a +45 degree polarized RF connection	N-type/50 Ω coaxial
	5 GHz	The AP antenna supports a horizontally polarized RF connection	
Ground Lug		Unit chassis ground. Refer to the <i>installation instructions</i> for information	10 AWG copper wire

PMP/PTP 450 Series interfaces – SM/BH

The PMP 450 Series SM/BH interfaces are illustrated in [Figure 12](#) and [Figure 13](#).

[Figure 12](#): PMP/PTP 450 Series – SM/BH Integrated interfaces

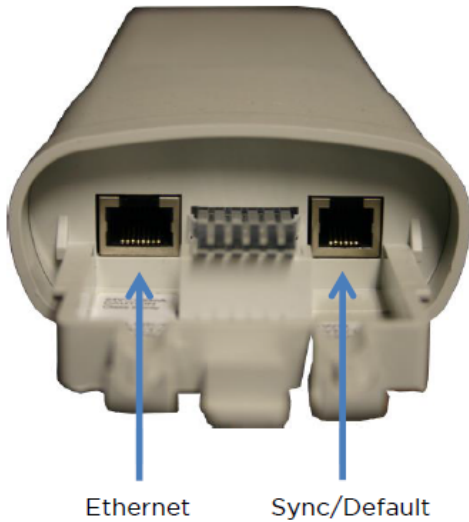

[Figure 13](#): PMP/PTP 450 Series – SM/BH Connectorized interfaces



Note

As per the guidelines of Underwriters Laboratory (UL), the Ground Lug on the radiated SM is not required.

Figure 14: PMP 450d Series - SM Integrated Dish



Figure 15: PMP 450 Series – SM 3 GHz Integrated



Figure 16: PTP 450 Series – BHM/BHS



Table 42: PMP/PTP 450 Series interfaces – SM/BH interface descriptions and cabling

Interface	Band	Function	Connector/Cabling
Ethernet		Canopy-style PoE supports 24-30 VDC and 10/100BASE-T Ethernet	RJ45/Cat 5e
AUX		GPS synchronization input and output, alignment tone audio output, and a default plug port	RJ12/custom Cat 5e
RF Port A	2.4 GHz, 3 GHz	-45 degree polarized RF connection to AP antenna	N-type/50 Ω coaxial
	5 GHz	Vertically polarized RF connection to AP antenna	
RF Port B	2.4 GHz, 3 GHz	+45 degree polarized RF connection to AP antenna	N-type/50 Ω coaxial
	5 GHz	Horizontally polarized RF connection to AP antenna	
Ground Lug		Unit chassis ground. Refer to the <i>installation instructions</i> for information	10 AWG copper wire

PMP 450 MicroPoP Series (Omni, Sector and Connectorized) interfaces - AP

Omni and Sector AP interfaces

The PMP 450 MicroPoP Series Omni and Sector AP interfaces are illustrated [Figure 17](#) in and [Figure 18](#).

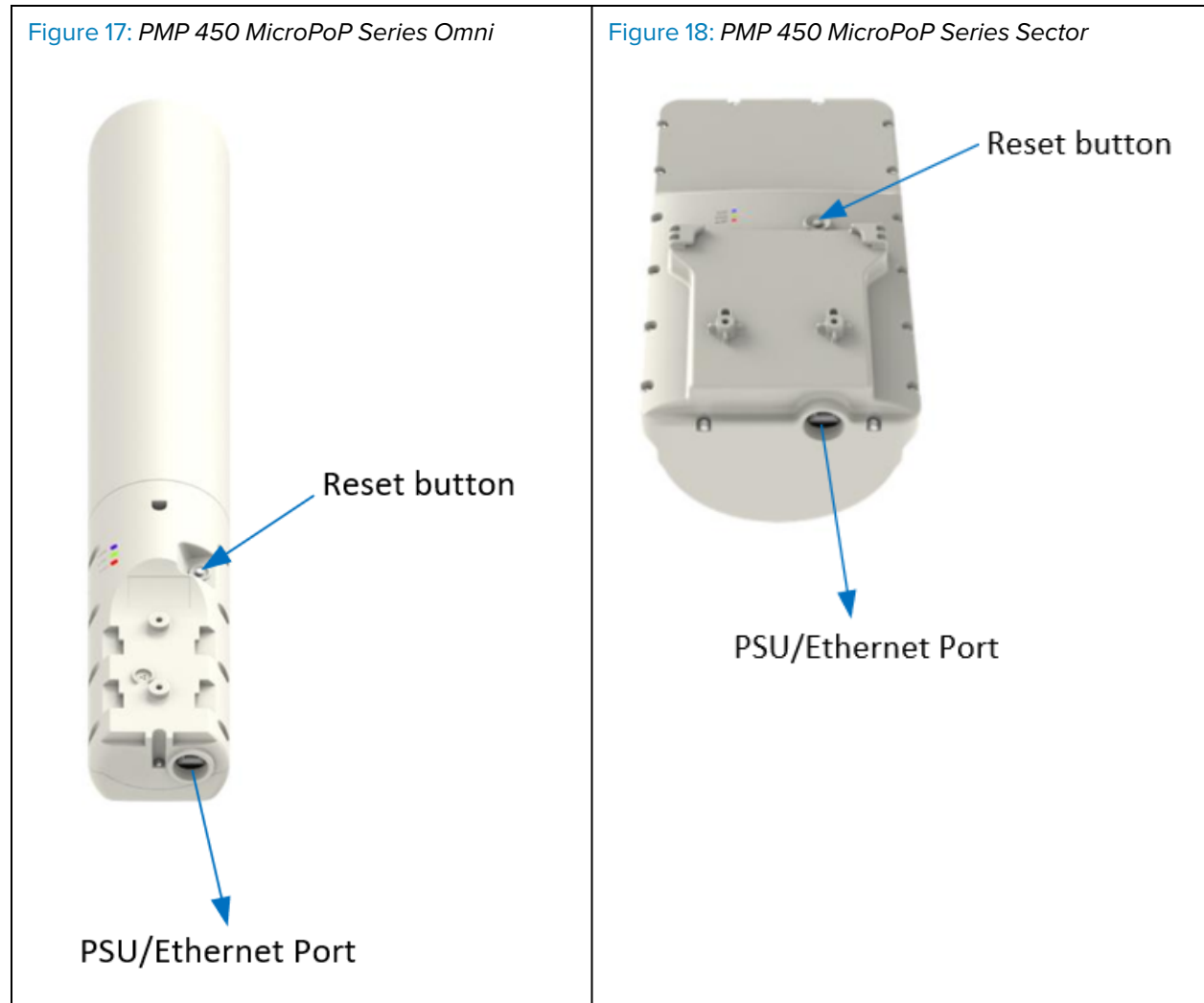

Table 43: PMP 450 MicroPoP Series Omni/Sector interface details

Interface	Function	Connector/Cabling
Main/Power Port	PoE supports 46-59 V DC, is 802.3af compatible, and offers 10/100/1000BASE-T Ethernet, as well as Cambium/Canopy Sync-over-power.	RJ45/Cat 5e

Interface	Function	Connector/Cabling
Reset button	<ul style="list-style-type: none"><li data-bbox="430 262 820 294">• Short press: Reboot the device<li data-bbox="430 304 787 336">• Long press: Recovery mode	-

Connectorized AP interfaces

The PMP 450 MicroPoP Series Connectorized AP interfaces are illustrated in [Figure 19](#).

[Figure 19](#): PMP 450 MicroPoP Series Connectorized AP interfaces

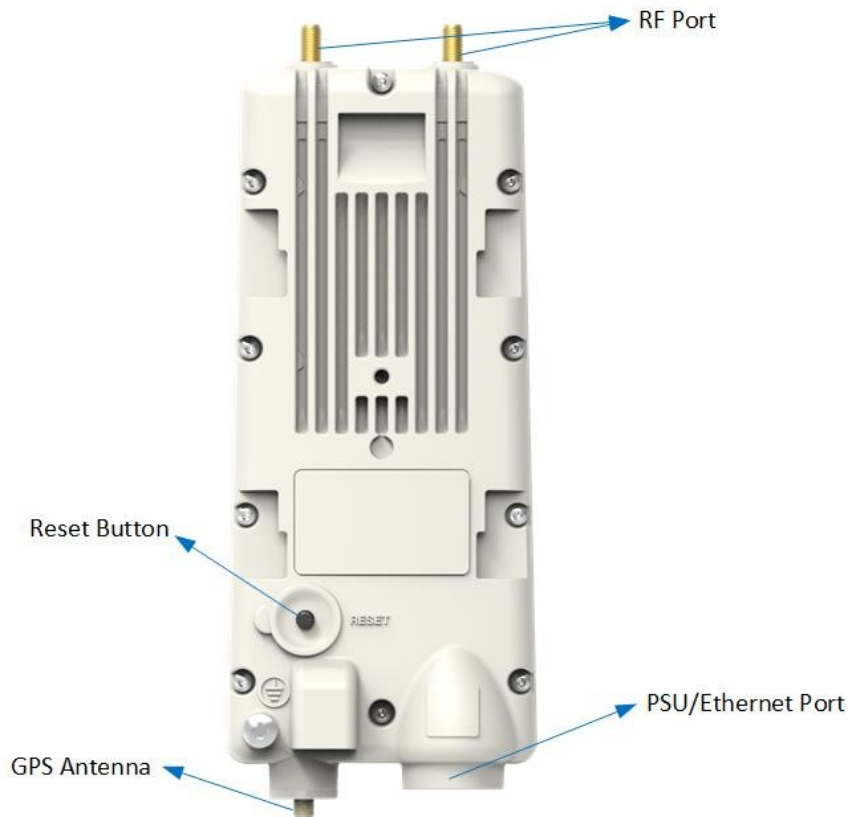

Table 44: PMP 450 MicroPoP Series Connectorized interface details

Interface	Function	Connector/Cabling
Main/Power Port	PoE supports 46-59 V DC, is 802.3af compatible, and provides 10/100/1000BASE-T Ethernet, along with Cambium/Canopy Sync-over-power.	RJ45/Cat 5e
Reset button	<ul style="list-style-type: none"> • Short press: Reboot the device • Long press: Recovery mode 	-
GPS Antenna	Connect to external GPS active antenna puck	GPS antenna with SMA connector
RF Ports	Horizontally and vertically polarized RF connections to AP antenna	Reverse polarity SMA/50 Ω coaxial
Ground Lug	Unit chassis ground. Refer to the <i>Installation Instructions</i> for more information	10 AWG copper wire

450v Series interfaces AP – 5/6 GHz

The 5/6 GHz 450v Series AP interfaces are illustrated below.

Figure 20: 5/6 GHz 450v Series AP interfaces

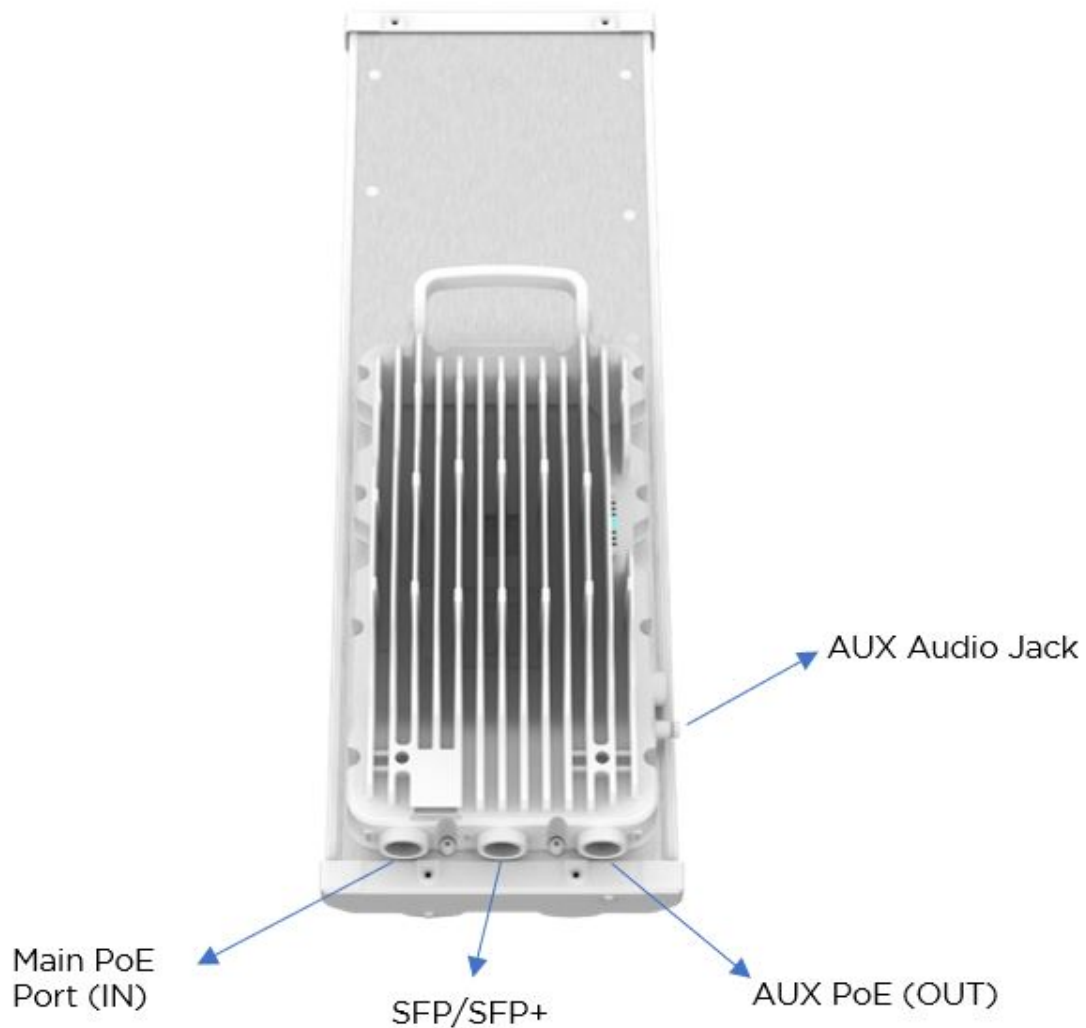

Table 45: 5/6 GHz 450v Series AP interface details

Interface	Function	Connector/Cabling
Main PoE Port (IN)	Power over Ethernet 46 - 59 V DC 802.3bt compatible, 10/100/1000BASE-T Ethernet, plus Cambium/Canopy Sync-over-power.	RJ45/Cat 5e
AUX PoE (OUT)	10/100/1000BASE-T Ethernet, Power over Ethernet PSE Output 56V DC 802.3at compatible.	RJ45/custom Cat 5e

Interface	Function	Connector/Cabling
SFP/SFP+	10G BASE-SR/10G BASE-LR/1G Base-SX using optional SFP+/SFP optical or copper module SFP-10G-SX / SFP-10G-LX using optional SFP optical or copper module	Fiber
AUX Audio Jack	GPS synchronization input and output, UGPS/cnPulse power output, alignment tone audio output	3.5 mm TRRS audio/standard headphones or custom sync cable
Ground Lug	Unit chassis ground. Refer to the <i>Installation Instructions</i> for more information	10 AWG copper wire

450v Series interfaces SM/BHM/BHS (4x4) – 5/6 GHz

The 5/6 GHz 450v Series SM/BHM/BHS (4x4) interfaces are illustrated below.

Figure 21: 5/6 GHz 450v Series SM/BHM/BHS (4x4) interfaces

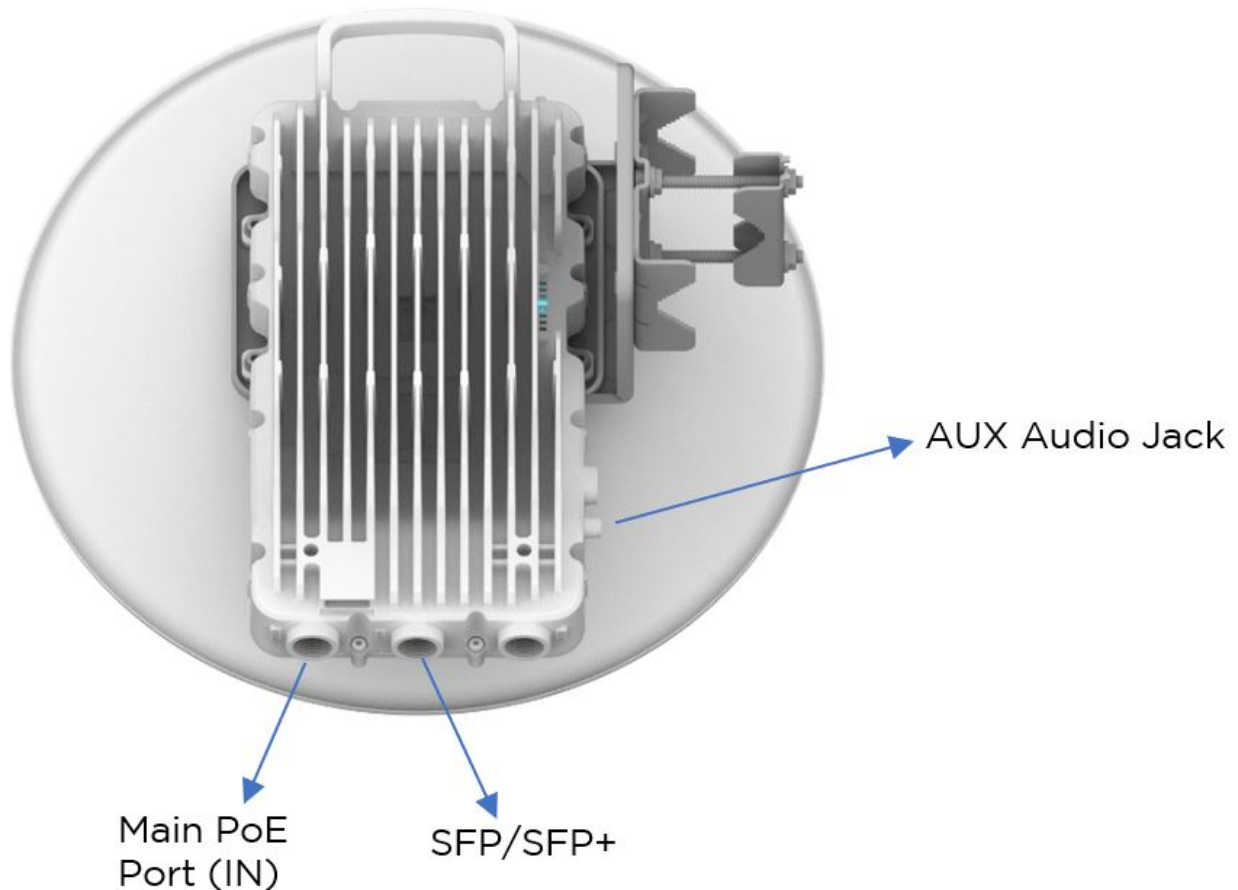

Table 46: 5/6 GHz 450v Series SM/BHM/BHS (4x4) interface details

Interface	Function	Connector/Cabling
Main PoE Port (IN)	Power over Ethernet 46 - 59 V DC 802.3bt compatible, 10/100/1000BASE-T Ethernet, plus Cambium/Canopy Sync-over-power	RJ45/Cat 5e
SFP/SFP+	10G BASE-SR/10G BASE-LR/1G Base-SX using optional SFP+/SFP optical or copper module SFP-10G-SX/ SFP-10G-LX using optional SFP optical or copper module.	Fiber or copper
AUX Audio Jack	GPS synchronization input and output, UGPS/cnPulse power output, alignment tone audio output	3.5 mm TRRS audio/standard headphones or custom

Interface	Function	Connector/Cabling
		sync cable
Ground Lug	Unit chassis ground. Refer to the <i>Installation Instructions</i> for more information	10 AWG copper wire

450v Series interfaces SM/BHM/BHS (2x2) – 5/6 GHz

The 5/6 GHz 450v Series SM/BHM/BHS (2x2) interfaces are illustrated below.

Figure 22: 5/6 GHz 450v Series SM/BHM/BHS (2x2) interfaces

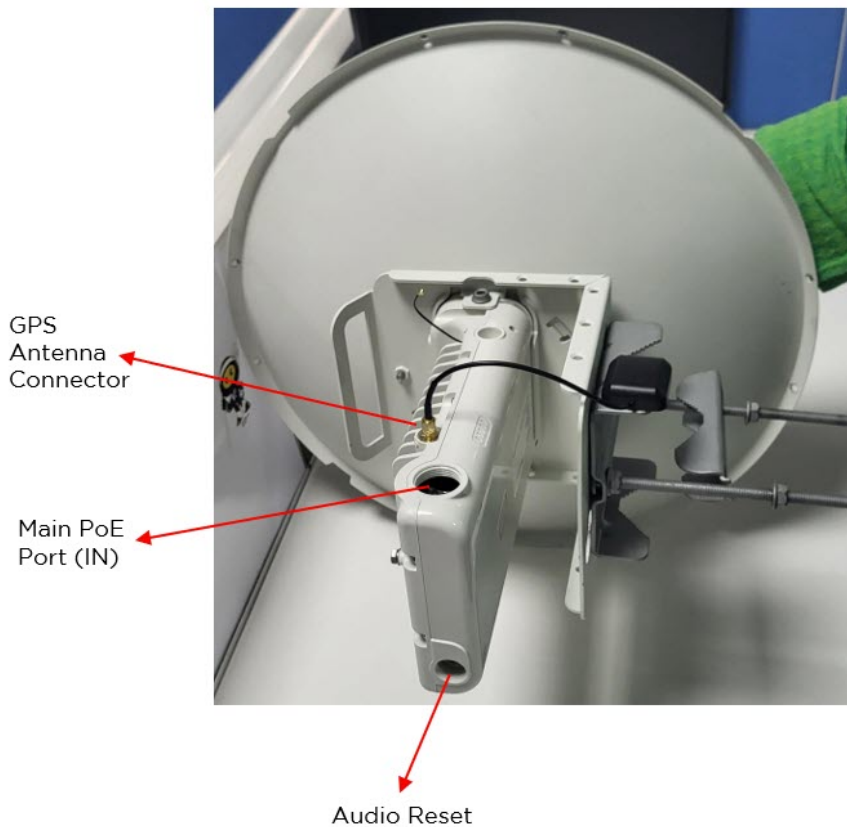

Table 47: 5/6 GHz 450v Series SM/BHM/BHS (2x2) interface details

Interface	Function	Connector/Cabling
Main PoE Port (IN)	Power over Ethernet 46 - 59 V DC 802.3bt compatible, 10/100/1000BASE-T Ethernet, plus Cambium/Canopy Sync-over-power.	RJ45/Cat 5e
GPS Antenna connector	It connects a GPS antenna to a GPS receiver, allowing the receiver to receive signals from GPS satellites and determine the receiver's location	SMA female connector

Interface	Function	Connector/Cabling
AUX Audio Jack	GPS synchronization input and output, UGPS/cnPulse power output, alignment tone audio output.	3.5 mm TRRS audio/standard headphones or custom sync cable
Ground Lug	Unit chassis ground. Refer to the <i>Installation Instructions</i> for more information	10 AWG copper wire

ATEX/HAZLOC variants

PTP/PMP 450i series products are available in ATEX/Hazloc variants for operation in locations where explosive gas hazards exist, as defined by Hazloc (USA) and ATEX (Europe). ATEX/HAZLOC variants are similar to the standard product, with the exception that:

- ODUs supplied with full capacity license
- Frequency range is restricted to 4940 MHz to 5850 MHz
- Maximum EIRP generated by ODU is restricted to comply with the ATEX and HAZLOC standards

In order to comply with specific radio regulations in the USA, Canada, and the EU, Cambium supplies products approved for these regions as well as the rest of the world under different models and part numbers. These models and part numbers are listed in the PMP 450i Integrated ODU models/part numbers and PTP 450i Series – Con ODU part numbers.

Diagnostic LEDs

The diagnostic LEDs of 450 Platform Family ODUs are as shown below.



Note

The colors shown in the diagram may differ from the actual color displayed by the AP/BHM, depending on its current status.

AP/BHM LEDs

The diagnostic LEDs report the information about the status of the AP/BHM.

Figure 23: 450m AP, 450i AP/BHM and 450 AP/BHM diagnostic LEDs





ODU LED Display	LED Labels					
PMP 450m Series - AP						
	MAIN LNK+AC T/5	AUX LNK+AC T/4	GPS/3	SES/2	SYN/1	PWR
PMP/PTP 450i Series - AP/BHM						
	MAIN LNK/5	ACT/4	GPS/3	SES/2	SYN/1	PWR
PMP/PTP 450 Series - AP/BHM						
	MAIN LNK/5	ACT/4	GPS/3	SES/2	SYN/1	PWR
PMP/PTP 450 Series - AP						
	MAIN LNK/5	ACT/4	GPS/3	SES/2	SYN/1	PWR
PMP/PTP 450 Series - BHM						
	ACT/4	GPS/3	SES/2	SYN/1	PWR	MAIN LNK/5

Table 48: 450m AP, 450i AP/BHM and 450 AP/BHM LED descriptions

LED	Color when active	Status information provided	Notes
PWR	Red	DC power	Always lit after 10-20 seconds of power on
SYN/1	Yellow	Presence of sync	-
SES/2	Green	Unused	-

LED	Color when active	Status information provided	Notes
GPS/3	Red	Pulse of sync	Lit when the AP/BHM is getting a sync pulse from a GPS source goes along with SYN/1
ACT/4	For 450 and 450i Yellow	Presence of data activity on the Ethernet link	Flashes during data transfer. Frequency of flash is not a diagnostic indication.
AUX LNK + ACT/4	For 450m Series Red/Green (bi-colored for 10/100)	Aux port link speed and activity	Flashes to indicate Ethernet activity on Aux port. Indicates the speed based on the following colors: <ul style="list-style-type: none"> • 10BASE-T = Red • 100BASE-T = Green
MAIN LNK/5	For 450i Red/Green/Orange (bi-colored for 10/100/1000)	Activity on Main port link	Continuously lit when link is present. Indicates the speed based on the following colors: <ul style="list-style-type: none"> • 10BASE-T = Red • 100BASE-T = Green • 1000BASE-T = Orange
	For 450 AP Orange/Green/Yellow (10/100/1000)	Ethernet link	Continuously lit when link is present. Indicates the speed based on the following colors: <ul style="list-style-type: none"> • 10BASE-T = Orange • 100BASE-T = Green • 1000BASE-T = Yellow
	For 450 BHM Green		Continuously lit when link is present. Indicates the speed based on the following colors: <ul style="list-style-type: none"> • 10BASE-T = Green • 100BASE-T = Green
MAIN LNK + ACT/5	For 450m Series Red/Green/Orange (bi-colored for 10/100/1000)	Main port link speed and activity	Flashes to indicate data transfer speed and activity.

Figure 24: 5 GHz 450b Mid-Gain and High Gain BHM diagnostic LEDs













ODU LED Display	LED Labels				
PTP 450b Mid-Gain Series – BHM					
					
	ETH	GPS	SES	SYNC	POWER
PTP 450b 5 GHz High Gain Series – BHM					
					
	ETH	GPS	SES	SYNC	POWER

Table 49: 5 GHz 450b Mid-Gain and High Gain BHM LED descriptions

LED	Color when active	Status information provided	Notes
POWER	Blue	DC power	Always lit after 10-20 seconds of power on
SYNC	Green	Presence of sync	-
SES	Yellow	Unused	-
GPS	Red	Pulse of sync	Lit when the BHM is getting a sync pulse from a GPS source goes along with SYNC
ETH	Red/Green/Orange (multi-colored for 10/100/1000)	Presence of data activity on the Ethernet link	<p>Lit when link is present. Indicates the speed based on the following colors:</p> <ul style="list-style-type: none"> • 10BASE-T = Red • 100BASE-T = Green • 1000BASE-T = Orange <p>Flashes during data transfer. Frequency of flash is not a diagnostic indication.</p>

Figure 25: 3 GHz 450b High Gain BHM, 5 GHz 450 MicroPoP Omni/Sector/Connectorized AP, 5 GHz 450b Retro BHM and 5 GHz 450b Connectorized BHM diagnostic LEDs















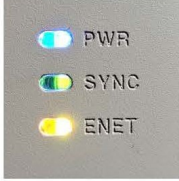

ODU LED Display	LED Labels		
3 GHz 450b High Gain BHM			
			
	ETH	SES/SYN	PWR
5 GHz 450 MicroPoP Omni/Sector/Connectorized AP			
			
	PWR	SYNC	ENET
5 GHz 450b Retro BHM			
			
	PWR	SYNC	ENET
5 GHz 450b Connectorized BHM			
			
	PWR	SYNC	ENET

Table 50: 3 GHz 450b High Gain BHM LED descriptions

LED	Color when active	Status information provided	Note
PWR	Blue	DC power	Always lit after power on
ETH	Red/Green/Orange	Flashes in presence of data activity on the Ethernet link	Indicates the speed based on the following colors: <ul style="list-style-type: none"> • 10BASE-T = Red • 100BASE-T = Green

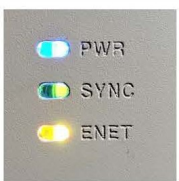
LED	Color when active	Status information provided	Note
			<ul style="list-style-type: none"> • 1000BASE-T = Orange
SES/SYN	Yellow/Green	Sync status: <ul style="list-style-type: none"> • Generating sync = Yellow • Receiving sync = Green • Solid = Unit transmitting • Blinking = Unit synchronized, but not transmitting 	

Table 51: 5 GHz 450 MicroPoP Omni/Sector/Connectorized AP, 5 GHz 450b Retro BHM and 5 GHz 450b Connectorized BHM LED descriptions

LED	Color when active	Status information provided	Note
PWR	Blue	DC power	Always lit after power on
ENET	Red/Green/Orange	Flashes in presence of data activity on the Ethernet link	Indicates the speed based on the following colors: <ul style="list-style-type: none"> • 10BASE-T = Red • 100BASE-T = Green • 1000BASE-T = Orange
SYNC	Yellow/Green	Sync status: <ul style="list-style-type: none"> • Generating sync = Yellow • Receiving sync = Green • Solid = Unit transmitting • Blinking = Unit synchronized, but not transmitting 	

Figure 26: 5/6 GHz 450v Series AP LED descriptions









ODU LED Display	LED Labels							
450v Series – AP (4x4)								
								
	PWR	SYN	SES	GPS	ETH MAIN	ETH AUX	SFP+	AUX PWR

Table 52: 5/6 GHz 450v Series AP LED descriptions

LED	Color when active	Status information provided	Notes
PWR	Yellow: While booting Blue: The radio has fully booted.	DC power	Always lit after 10-20 seconds of power on.
SYN	Green	Presence of sync	-
SES	Yellow	Unused	-
GPS	Green	Pulse of sync	Lit when the AP is getting a sync pulse from a GPS source; goes along with SYN.
ETH MAIN	Red/Green/Orange (multi-colored for 10/100/1000)	Main Port Ethernet link	Lit when link is present. Indicates the speed based on the following colors: <ul style="list-style-type: none"> • 10BASE-T = Red • 100BASE-T = Green • 1000BASE-T = Orange Flashes during data transfer. Frequency of flash is not a diagnostic indication.
ETH AUX	Red/Green/Orange (multi-colored for 10/100/1000)	Aux Port Ethernet link	Lit when link is present. Indicates the speed based on the following colors: <ul style="list-style-type: none"> • 10BASE-T = Red • 100BASE-T = Green • 1000BASE-T = Orange Flashes during data transfer. Frequency of flash is not a diagnostic indication.
SFP+	Green	SFP+ Status	Always lit when SFP+ link is active.
AUX PWR	Green	Aux Ethernet Port PoE Status	Always lit when Aux Ethernet Port PoE is active.

SM/BHS/BHM LEDs

The SM/BHS/BHM LEDs provide different status indicators for the radio based on the operating modes. When in **Operating** mode, a SM/BHS/BHM registers and passes traffic normally. In aiming mode, a

SM/BHS/BHM does not register or pass traffic but displays the strength of received radio signals (based on the radio channel selected via **Tools -> Alignment**) through the LED panel.

Figure 27: 450i and 450 SM/BHS diagnostic LEDs

ODU LED Display	LED Labels					
PMP/PTP 450i Series - SM/BHS						
						
	MAIN LNK/5	ACT/4	GPS/3	SES/2	SYN/1	PWR
PMP/PTP 450 Series - SM/BHS						
						
	MAIN LNK/5	ACT/4	GPS/3	SES/2	SYN/1	PWR

Table 53: 450i and 450 SM/BHS LED descriptions

Status information provided				
LED	Color when active	SM/BHS in Operating Mode	SM/BHS in Aiming Mode	Note
PWR	Red	DC power		Always lit after 10-20 seconds of power on
SYN/1	Yellow	Presence of sync	These three LEDs act as a bar graph to indicate the relative quality of alignment. As power level improves during alignment, more of these LEDs are lit.	Lit when SM/BHS is in sync with an AP/BHM.
SES/2	Green	Session Indicator		Lit when SM/BHS is in session.
GPS/3	Red	Unused		Unused
ACT/4	Yellow	Presence of data activity on the Ethernet link	Presence of data activity on the Ethernet link	Flashes during data transfer. Frequency of flash is not a diagnostic indication.

Status information provided				
LED	Color when active	SM/BHS in Operating Mode	SM/BHS in Aiming Mode	Note
MAIN LNK/5	For 450i Series Red/Green/Orange (bi-colored for 10/100/1000)	Ethernet link		Continuously lit when link is present. Indicates the speed based on the following colors: <ul style="list-style-type: none"> • 10BASE-T = Red • 100BASE-T = Green • 1000BASE-T = Orange
	For 450 Series Green	Ethernet link		Continuously lit when link is present.

Figure 28: 450v 2x2 5/6 GHz SM/BHM/BHS, 5 GHz 450b Mid-Gain and High Gain SM/BHS diagnostic LEDs

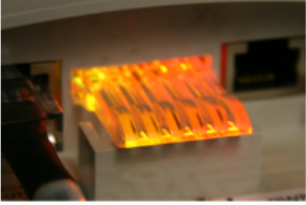





ODU LED Display	LED Labels				
450v 2x2 5/6 GHz - SM					
					
	POWER	SYNC	SESSION	GPS	ETH MAIN
PTP 450b Mid-Gain Series - SM/BHS					
					
	POWER	SYNC	SES	GPS	ETH
PTP 450b 5 GHz High Gain Series - SM/BHS					
					
	POWER	SYNC	SES	GPS	ETH

Table 54: 5 GHz High Gain and Mid-Gain 450b SM/BHS LED descriptions

Status information provided				
LED	Color when active	SM/BHS in Operating Mode	SM/BHS in Aiming Mode	Note
POWER	Blue	DC power		Flashes Yellow during boot-up. Flashes Blue when operating. Always lit after 10-20 seconds of power on.

Status information provided				
LED	Color when active	SM/BHS in Operating Mode	SM/BHS in Aiming Mode	Note
SYNC	Green	Presence of sync	These three LEDs act as a bar graph to indicate the relative quality of alignment. As power level improves during alignment, more of these LEDs are lit.	Lit when SM/BHS is in sync with an AP/BHM
SESSION/SES (450v/450b)	Yellow	Session Indicator		Lit when SM/BHS is in session
GPS	Green/Red (450v/450b)	Unused		Unused
ETH MAIN/ETH (450v/450b)	Red/Green/Orange (10/100/1000)	Ethernet Link		Flashes during data transfer. Frequency of flash is not a diagnostic indication <ul style="list-style-type: none"> • 10BASE-T = Red • 100BASE-T = Green • 1000BASE-T = Orange

Figure 29: 3 GHz 450b High Gain SM/BHS, 5 GHz 450b Retro SM/BHS and 5 GHz 450b Connectorized SM/BHS diagnostic LEDs

ODU LED Display	LED Labels		
PMP/PTP 450b 3 GHz High Gain Series – SM/BHS			
			
	ETH	SES/SYN	PWR
5 GHz 450b Retro SM/BHS			
			
	PWR	SYNC	ENET
5 GHz 450b Connectorized SM/BHS			
			
	PWR	SYNC	ENET



Note

The 3 GHz 450b has its status LEDs located beneath the cover behind the dish. During installation, the LEDs can be viewed by unclipping the rearmost door.



Table 55: 3 GHz 450b High Gain SM/BHS LED descriptions

Status information provided				
LED	Color when active	SM/BHS in Operating Mode	SM/BHS in Aiming Mode	Note
PWR	Blue	DC power		Always lit after power on
ETH	Red/Green/Orange (10/100/1000)	Ethernet Link		Flashes during data transfer. Frequency of flash is not a diagnostic indication. <ul style="list-style-type: none"> • 10Base-T = Red • 100BASE-T = Green • 1000BASE-T =Orange
SES/ SYN	Yellow/Green	Session status: <ul style="list-style-type: none"> • Scanning = Blinking yellow • Registering = Solid yellow • Registered = Solid green 	This LED indicates when the signal level is sufficient for normal operation. When the power rises above this threshold, the LED color changes from Yellow to Green.	

Table 56: 5 GHz 450b Retro SM/BHS and 5 GHz 450b Connectorized SM/BHS LED descriptions

Status information provided				
LED	Color when active	SM/BHS in Operating Mode	SM / BHS in Aiming Mode	Note
PWR	Blue/Yellow	DC power		Always lit after power on
SYNC	Green/Yellow	Session status: <ul style="list-style-type: none"> Scanning = Blinking green Registering = Solid green Registered = Solid yellow 	This LED indicates when the signal level is sufficient for normal operation. When the power rises above this threshold, the LED color changes from Green to Yellow.	
ENET	Red/Green/Orange (10/100/1000)	Ethernet Link		Flashes during data transfer. Frequency of flash is not a diagnostic indication. <ul style="list-style-type: none"> 10BASE-T = Red 100BASE-T = Green 1000BASE-T = Orange

Figure 30: 5/6 GHz 450v 4x4 SM/BHM/BHS LED descriptions







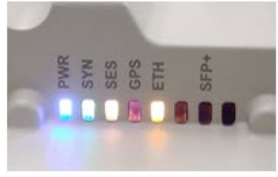

ODU LED Display	LED Labels							
450v Series – SM (4x4)								
								
	PWR	SYN	SES	GPS	ETH	Unused	SFP+	Unused

Table 57: 5/6 GHz 450v Series SM LED descriptions

LED	Color when active	SM in "Operating" Mode	SM in "Aiming" Mode	Notes
PWR	Yellow: While booting Blue: The radio has fully booted.	DC power	DC power	Always lit after 10-20 seconds of power on.
SYN	Green	Presence of sync	These three LEDs serve as a bar graph to indicate the relative quality of alignment. As power level improves during alignment, more of these LEDs light up.	Lit when the SM is in sync with an AP.
SES	Yellow	Session indicator	These three LEDs serve as a bar graph to indicate the relative quality of alignment. As power level improves during alignment, more of these LEDs light up.	Lit when the SM is in sync with an AP.
GPS	Green	Unused	These three LEDs serve as a bar graph to indicate the relative quality of alignment. As power level improves during alignment, more of these LEDs light up.	-
ETH	Red/Green/Orange (multi-colored for 10/100/1000)	Ethernet link	Ethernet link	Lit when link is present. Indicates the speed based on the following colors: <ul style="list-style-type: none"> • 10BASE-T = Red • 100BASE-T = Green • 1000BASE-T = Orange

LED	Color when active	SM in "Operating" Mode	SM in "Aiming" Mode	Notes
				Flashes during data transfer. Frequency of flash is not a diagnostic indication.
SFP+	Green	SFP+ Status	SFP+ Status	Always lit when SFP+ link is active.

Operating Mode

- Scanning:
 - For hardware with 5, 6 and 8 LEDs: If the SM/BHS is not registered to AP/BHM, then these LEDs cycle on and off from left to right (SYN/1, SES/2, and GPS/3).
 - For hardware with 3 LEDs: If the SM/BHS is not registered to AP/BHM, then SES/SYN session blinks yellow.
- Ethernet Link:
 - For 450m AP, the MAIN LNK + ACT/5 LED is active when the Main port link is present and the AUX LNK + ACT/4 LED is active when the Aux port link is present.
 - For 450/450i AP/BHM/BHS, the MAIN LNK/5 LED is lit continuously when the link is present.
 - For 5/6 GHz 450v AP, the ETH MAIN LED is active when the Main port link is present and the ETH AUX LED is active when the Aux port link is present. For 5/6 GHz 450v SM, the ETH LED is active when the Main port link is present.
- Data Transfer:
 - For the 450m AP, the MAIN LNK + ACT/5 LED flashes to indicate data transfer speed and activity on the Main port, while the AUX LNK + ACT/4 LED flashes to indicate data transfer speed and activity on the Aux port.
 - For 450/450i AP/BHM, the ACT/4 LED flashes during data transfer.
 - For 450/450i SM/BHS, the ACT/4 LED flashes during data transfer.
 - For 450b 3 GHz and 5 GHz, the ETH LED flashes during data transfer.
 - For MicroPoP 5 GHz, the ETH LED flashes during data transfer.
 - For 5/6 GHz 450v AP, the ETH MAIN LED flashes to indicate data transfer activity on the Main port, and the ETH AUX LED flashes to indicate data transfer activity on the AUX port. For 6 GHz 450v SM/BHM/BHS, the ETH flashes to indicate data transfer activity on the Main port.

Aiming Mode

For hardware with 5, 6 and 8 LEDs, the 3 LEDs (SYN/1, SES/2, and GPS/3) are combined to form a 3-position bar graph. The number of lit LEDs corresponds to the received power level, with more lit LEDs indicating better power reception. In hardware with 3 LEDs, the SES/SYN LED serves as an indicator of signal sufficiency for normal operation. When the power surpasses this threshold, the LED changes color from Yellow to Green. The LED colors do not hold any specific meaning apart from aiding in differentiating between positions.

Power supply options

The ODU is powered by a PoE injector, except for the 3 GHz PMP 450m model where power and data are supplied separately. All power injectors/power supplies in the Cambium Networks range are designed for indoor environments. The Cat 5e cable with RJ45 connectors is used to connect the power injector to the ODU and network terminating equipment. [Table 58](#) summarizes the Cambium Networks power supply variants available for each 450 radio models. Alternatively, most of these radios can be powered using a Cambium cnMatrix switch instead of a standalone PoE injector.

Table 58: Power supply variants available for PMP 450 radio models

Model	30 V DC	56 V DC	802.3af	802.3at	802.3bt	N000900L001B /C Gigabit (15W)	N000900L00 2A 100Base T (15W) - obsolete	N000000L03 4A (AC) – 30W, 56 V DC	N000000L14 2A -60W, 56V, 5GbE	C000000L141 A -60W, 56 V, 10GbE	C000065L00 2D (AC+DC) – 100W	N000000L05 4B (AC) 54V 240W
PMP 450 AP	X	-	-	-		X	X*	-	-	-	-	-
PMP 450 SM	X	-	-	-		X*	X*	-	-	-	-	-
PTP 450	X	-	-	-		X*	X*	-	-	-	-	-
PMP / PTP 450b	X	-	-	-		X	X*	-	-	-	-	-
PMP 450i AP	-	X	-	X		-	-	X	X	X	X	-
PMP 450i SM	-	X	-	X		-	-	X	X	X	X	-
PTP 450i	-	X	-	X		-	-	X	X	X	X	-

Model	30 V DC	56 V DC	802.3af	802.3at	802.3bt	N000900L001B /C Gigabit (15W)	N000900L00 2A 100Base T (15W) - obsolete	N000000L03 4A (AC) – 30W, 56 V DC	N000000L14 2A -60W, 56V, 5GbE	C000000L141 A -60W, 56 V, 10GbE	C000065L00 2D (AC+DC) – 100W	N000000L05 4B (AC) 54V 240W
5 GHz PMP 450m	-	X	-	-		-	-	-	-	X	X	-
3 GHz PMP 450m	-	-	-	-		-	-	-	-	X	-	X
PMP 450 MicroPo P	-	X	-	X		-	-	X	X	X	X	-
450v					X				X**	X**	X	

*100BASE T-mode only (no Gigabit)

** Only when Aux PoE Out is disabled

The AC line cord is supplied separately from the power supply. Regional variants are available.

Power supply – PMP 450m Series

The PMP 450m Series - 5 GHz AP supports powering on from the following power sources:

- AC+DC enhanced power injector ([Power supply – PMP 450m Series](#))
- CMM5 56 V power and sync injector module with external 240 W or 600 W power supply
- Cambium cnMatrix switch

PSU part numbers

Table 59: PSU part numbers for PMP 450m AP (5/3 GHz)

AP Model	Cambium description	Cambium part number
5 GHz	AC+DC enhanced power injector	C000065L002C
3 GHz	Power supply, AC, 54 V 240 W	N000000L054B

Power supply – PMP/PTP 450i Series

The PMP/PTP 450i Series supports powering on from the following powering sources:

- Power supply, 60 W, 56 V with 1000BASE-T or GigE
- AC+DC enhanced power injector
- PoE midspan, 60 W, -48 V DC input
- CMM4/CMM5 with external 56 V power supply and CMM4/CMM5 to 450i Series ODU cable (Dongle)
- CMM5 56 V power and sync injector module with external 240 W or 600 W power supply
- IEEE 802.3at power injector
- Cambium cnMatrix switch



Note

The 900 MHz SM is based on the 450 Series. Refer to the **Power supply-PMP/PTP 450 Series** for more information.



Warning

- Always use an appropriately rated and approved AC supply cord-set in accordance with the regulations of the country where it is being used.
- The PMP 450 Ruggedized High Gain Integrated Subscriber Module (Cambium part numbers C035045C014A and C036045C014A), while encapsulated in a 450i-type enclosure, requires 30 V DC power for proper operation. Using a 56 V DC power supply can cause damage to the device.

Refer to the **Cabling** section for detailed information regarding the maximum cable lengths between the power injector and PMP/PTP 450i devices.

PSU part numbers

Table 60: PSU part numbers for PMP/PTP 450i Series

Cambium description	Cambium part number
Power supply, 60 W, 56 V with Gbps support	N000065L001B
AC+DC enhanced power injector	C000065L002C
Line Cord, Fig 8 – US	N000065L003A
Line Cord, Fig 8 – UK	N000065L004A
Line Cord, Fig 8 – EU	N000065L005A
PoE midspan, 60 W, -48 V DC input	N000000L036A
Power supply, 30 W, 56 V – Gbps support	N000000L034A

AC Power Injector N000065L001B

The AC power injector interfaces are shown in [Figure 31](#) and described in [Table 61](#).

Figure 31: AC Power Injector interfaces

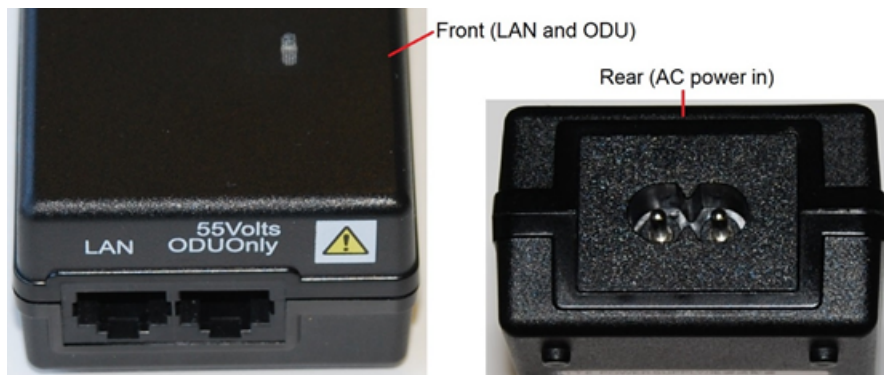

Table 61: AC Power Injector interface functions

Interface	Function
AC power in	AC power input (main supply)
ODU	RJ45 socket for connecting Cat5e cable to ODU
LAN	RJ45 socket for connecting Cat5e cable to network
Power (Green) LED	Power supply detection

AC+DC enhanced power injector C000065L002C

The AC+DC Enhanced power injector interfaces are shown in [Figure 32](#) and described in [Table 62](#).

Figure 32: AC+DC enhanced power injector interfaces

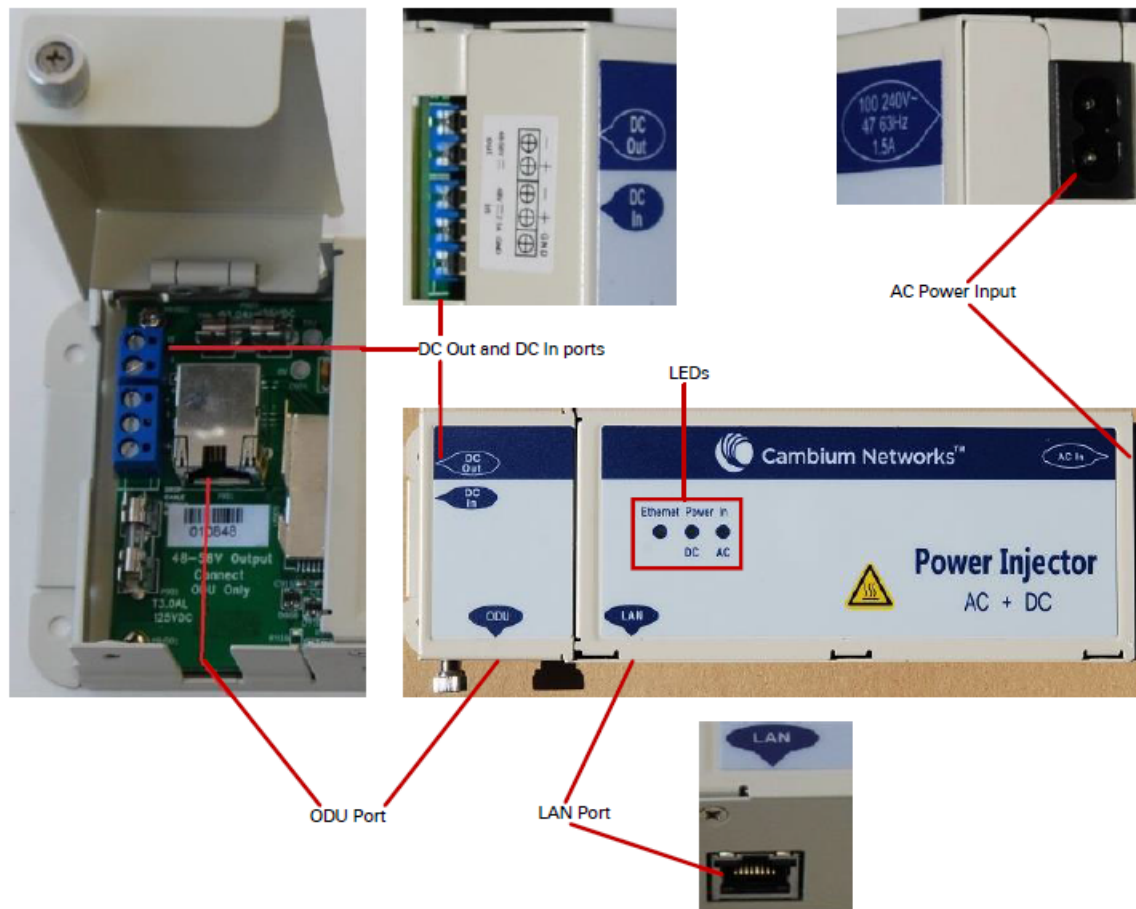

Table 62: AC+DC enhanced power injector interface functions

Interface	Function
100-240V 47-63Hz 1.7A	AC power input (main supply)
DC In	Alternative DC power supply input
DC Out	DC power output to a second PSU (for power supply redundancy) or to a NIDU
ODU	RJ45 socket for connecting Cat5e cable to ODU
LAN	RJ45 socket for connecting Cat5e cable to network
Power - AC (green) LED	Indicates power is applied at the AC power input
Power - DC (green) LED	Indicates power is applied at the DC In port
Ethernet (yellow) LED	The Ethernet traffic detector is used exclusively with the PTP 650 and PTP 700 families. It is not compatible with the PMP 450 platform products.



Note

The earlier power injector models only had a single power LED that combined the AC+DC indications.

-48 V DC Power Injector N000000L036A

The DC Power injector interfaces are shown in [Figure 33](#) and described in [Table 63](#).

Figure 33: -48 V DC power injector interfaces



Table 63: -48 V DC power injector interfaces

Interface	Function
DC input	36 to 60 V, 2 A
RJ45 sockets	Two (Data In and data & power Out)
LEDs	Two (AC and port)

Power supply – PMP/PTP 450b Series

The PMP/PTP 450b Series support powering from the following powering sources:

- Gigabit Ethernet capable power supply – 20 to 32 V DC, 15 W
- CMM4/CMM5 with external 29 V power supply
- CMM5 29 V power and sync injector module with external 240 W or 600 W power supply
- Cambium cnMatrix switch

Figure 34: -20 to 32 V DC power injector interfaces



Table 64: Power injector interfaces

Interface	Function
PSU/Ethernet	-20 to 32 V DC, 2A

PSU part numbers

Table 65: PSU part numbers for PMP/PTP 450b SM

Cambium description	Cambium part number
Gigabit Ethernet capable power supply -20 - 32 V DC, 15 W	N000900L001C

Power supply – 450v Series

The 450v Series supports powering on from the following power sources:

- Power supply: 60W, 56V with 5GigE or 10GigE
- AC+DC enhanced power injector
- PoE midspan: 60W, -48V DC input
- CMM4/CMM5 with an external 56V power supply and CMM4/CMM5 to 450i Series ODU cable (Dongle)
- CMM5 56V power and sync injector module with an external 240W or 600W power supply
- IEEE 802.3bt power injector
- Cambium cnMatrix switch



Warning

- Always use an appropriately rated and approved AC supply cord-set in accordance with the regulations of the country where it is being used.

Refer to the **Cabling** section for detailed information regarding the maximum cable lengths between the power injector and 450v devices.

PSU part numbers

Table 66: PSU part numbers for 450v Series

Cambium description	Cambium part number
Power supply, 60W, 56 V, and 5GbE	N000000L142A
Power supply, 60W, 56 V, and 10GbE	C000000L141A
AC+DC enhanced power injector	C000065L002D
Line Cord, Fig 8 – US	N000065L003A
Line Cord, Fig 8 – UK	N000065L004A
Line Cord, Fig 8 – EU	N000065L005A
PoE midspan, 60W, -48 V DC input	N000000L036A

AC Power Injector N000000L142A

The AC power injector interfaces are shown in [Figure 35](#) and described in [Table 67](#).

Figure 35: AC Power Injector interfaces- 5GbE



Table 67: AC Power Injector interface functions- 5GbE

Interface	Function
AC power in	AC power input (main supply)
ODU	RJ45 socket for connecting Cat5e cable to ODU
LAN	RJ45 socket for connecting Cat5e cable to network
Power (Green) LED	Power supply detection

AC Power Injector N000000L141A

The AC power injector interfaces are shown in [Figure 36](#) and described in [Table 68](#).

Figure 36: AC Power Injector interfaces-10GbE



Table 68: AC Power Injector interface functions-10GbE

Interface	Function
AC power in	AC power input (main supply)
ODU	RJ45 socket for connecting Cat5e cable to ODU
LAN	RJ45 socket for connecting Cat5e cable to network
Power (Green) LED	Power supply detection

Power supply – PMP/PTP 450 Series

The PMP/PTP 450 Series support powering from the following powering sources:

- Gigabit Ethernet capable power supply – 30 V DC, 15 W
- CMM4/CMM5 with external 29 V power supply
- CMM5 29 V power and sync injector module with external 240 W or 600 W power supply



Warning

The PMP 450 Ruggedized High Gain integrated SM (Cambium part numbers C035045C014A and C036045C014A), enclosed in a PMP 450i-type enclosure, contains 450 circuitry that must be powered via 30 V DC. Using a 56 V DC power supply can cause damage to the device.

PSU part numbers

Table 69: PSU part numbers for PMP/PTP 450 Series

Cambium description	Cambium part number
Gigabit Ethernet capable power supply - 30 V DC, 15 W	N000900L001C
Cable, UL power supply cord set, US	N000900L007A
Cable, UL power supply cord set, EU	N000900L008A
Cable, UL power supply cord set, UK	N000900L009A
Cable, UL power supply cord set, Brazil	N000900L010A

Gigabit Ethernet Capable Power Supply

The Gigabit Ethernet capable power supply interfaces are described in [Figure 37](#). This power supply requires procurement of an AC line cord that connects the outlet of the same (using IEC-60320 Type 5 connector). A list of available power supply cord options from Cambium Networks are given in [PSU part numbers for PMP/PTP 450 Series](#).

Table 70: Gigabit Ethernet capable power supply

Interface	Function
AC Input	90-264 V AC, 0.5 A rms @120 V AC/ 0.25 A rms @240 V AC, 47 to 63 Hz
DC Output	30.0 V DC +/-5%, 15 W, 500 mA max
Sockets	Two (Data In and data & power out)
LEDs	Green: LED Intensity determined by Level 5 efficiency

Figure 37: Gigabit Ethernet capable power supply



Power supply – PMP 450 MicroPoP series

The PMP 450 MicroPoP series supports powering from the following powering sources:

- Power supply, 15 W or 30 W, 56 V with 1000BASE-T or GigE
- AC+DC enhanced power injector
- PoE midspan, 60 W, -48 V DC input
- CMM4/CMM5 with external 56 V power supply and CMM4/CMM5 to PMP 450i Series ODU cable (Dongle)
- CMM5 56 V power and sync injector module with external 240 W or 600 W power supply
- IEEE 802.3at power injector
- Cambium cnMatrix switch

PSU part numbers

Table 71: PSU part numbers for PMP 450 MicroPoP Series

Cambium description	Cambium part number
Power supply, 30 W, 56 V, GbE DC injector, Indoor, Energy Level 6 supply, accepts C5 connector	N000000L034A
AC+DC enhanced power injector 58 V	C000065L002C
Line Cord, Fig 8 – US	N000065L003A
Line Cord, Fig 8 – UK	N000065L004A
Line Cord, Fig 8 – EU	N000065L005A
PoE midspan, 60 W, -48 V DC input	N000000L036A

AC Power Injector N000065L001B

The AC power injector interfaces are shown in [Figure 38](#) and described in [Table 72](#).

Figure 38: AC power injector interfaces



Table 72: AC power injector interface functions

Interface	Function
AC power in	AC power input (main supply)
ODU	RJ45 socket for connecting Cat5e cable to ODU
LAN	RJ45 socket for connecting Cat5e cable to network
Power (green) LED	Power supply detection

ODU mounting brackets and accessories

The list of supported mounting brackets are provided in [Table 73](#).

- The **Tilt bracket assembly** is the recommended bracket for the AP, SM, or BH integrated units
- The **Mounting bracket (Connectorized)** can be used where a low profile and ease of assembly of Connectorized AP, SM, or BH is required
- The **Mounting bracket (Integrated)** provides a wider range of adjustment for AP, SM, and BH integrated devices

Table 73: Accessories part numbers

Cambium description	Cambium part number
Mounting brackets	

Cambium description	Cambium part number
Tilt bracket assembly	N000045L002A
Mounting bracket (Integrated)	N000065L031A
Mounting bracket (Connectorized)	N000065L032A
Miscellaneous	
Ethernet cable adapter for CMM4/CMM5 (Dongle)	N000045L001A
RJ45 Gland spare – PG16 style (Quantity 10)	N000065L033A
Blanking plug pack (Quantity 10)	N000065L036A

Lightning protection

The 450 Platform family supports the lightning protection units listed in [Table 74](#).

The LPU provides the highest level of protection and is the recommended device. However, in cases where low-cost deployment is essential, such as for residential applications with SMs, the Gigabit Surge Suppressor may be used as an alternative.

Table 74: Lightning protection part numbers

Model	30 V DC	56 V DC	C000000L065 A Gigabit Ethernet Surge Suppressor	600SSH (10Base-T)	C000000L033 A Gigabit Ethernet Surge Suppressor	C000065L007 B Lightning Protection Unit kit	C000000L114 A DC Lightning Protection Unit kit
PMP 450 AP	X	-	X	X	-	-	-
PMP 450 SM	X	-	X	X	-	-	-
PTP 450	X	-	X	X	-	-	-
PMP 450b	X	-	X	X	-	-	-
PMP 450i AP	-	X	-	-	X	X	-
PMP 450i SM	-	X	-	-	X	X	-
PTP 450i	-	X	-	-	X	X	-
5 GHz PMP 450m AP	-	X	-	-	-	X	-

Model	30 V DC	56 V DC	C000000L065 A Gigabit Ethernet Surge Suppressor	600SSH (10Base-T)	C000000L033 A Gigabit Ethernet Surge Suppressor	C000065L007 B Lightning Protection Unit kit	C000000L114 A DC Lightning Protection Unit kit
*3 GHz PMP 450m AP	-	-	-	-	-	X	X
PMP 450 MicroPoP	-	X	-	-	X	X	-
450v	-	-	-	-	X	X	-



***Note**

The 3 GHz PMP 450m AP necessitates the utilization of the C000065L007B lightning protection unit kit for the Ethernet connection on the Main port, as well as the C000000L114A DC lightning protection unit kit for the DC PSU port.

Cambium Networks does not recommend deploying gas discharge tube-based surge protection on PMP 450i, PMP 450b, or PMP 450 MicroPoP platforms.

MicroPoP lightning arrester details

By lowering the omni antenna (mast O.D. 2.125 inches) on the mast, resulting in a 0.5m higher position than the product, it is possible to achieve lightning protection. However, this adjustment negatively impacts the omni pattern, as depicted in [Figure 39](#) by the orange trace. The orange pattern exhibits significant ripple due to the mast's proximity to the omni antenna, causing reflections. Alternatively, if a smaller diameter lightning rod is used, such as 0.3 to 0.625 inches (maximum 5/8 inches), the omni pattern remains unaffected (with ripple no worse than the baseline plastic mast). This is demonstrated by the light blue and blue traces below, representing the horizontal polarity pattern observed at 5.850 GHz. Similar results were obtained at 5.15 and 5.55 GHz.

[Figure 39](#) and [Figure 40](#) shows the desired implementation, using a 4-foot minimum lightning rod opposite of the omni radio.



Note

The 2.125 inch pipe does not extend any more than three inches above the omni mast bracket.

The locally sourced steel lightning rod should have a minimum length of 4 feet and a maximum thickness of 5/8 inches. It should be securely fastened using two separate hose clamps. The lightning rod should be positioned at least 0.5m higher than the top of the omni antenna, with a maximum extension of 3 feet (1m) above it. There are two types of lightning rods that can be used: a single blunt tip version or a dissipator on top. The dissipator concept involves clustering smaller rods together to generate multiple weak streamers instead of a single large streamer, which improves the lightning protection effectiveness. As an example, the LBA Group recommends using a 5 feet long, 5/8" O.D model DAT-160SS lightning rod.

It is mandatory to ground the mast. If it is not possible to ground the mast directly, a 6-8 AWG copper ground wire should be connected to the lightning rod base and run down to the ground (PE) bonding point.

Figure 39: MicroPoP Omni antenna implementation pattern (Horizontal)

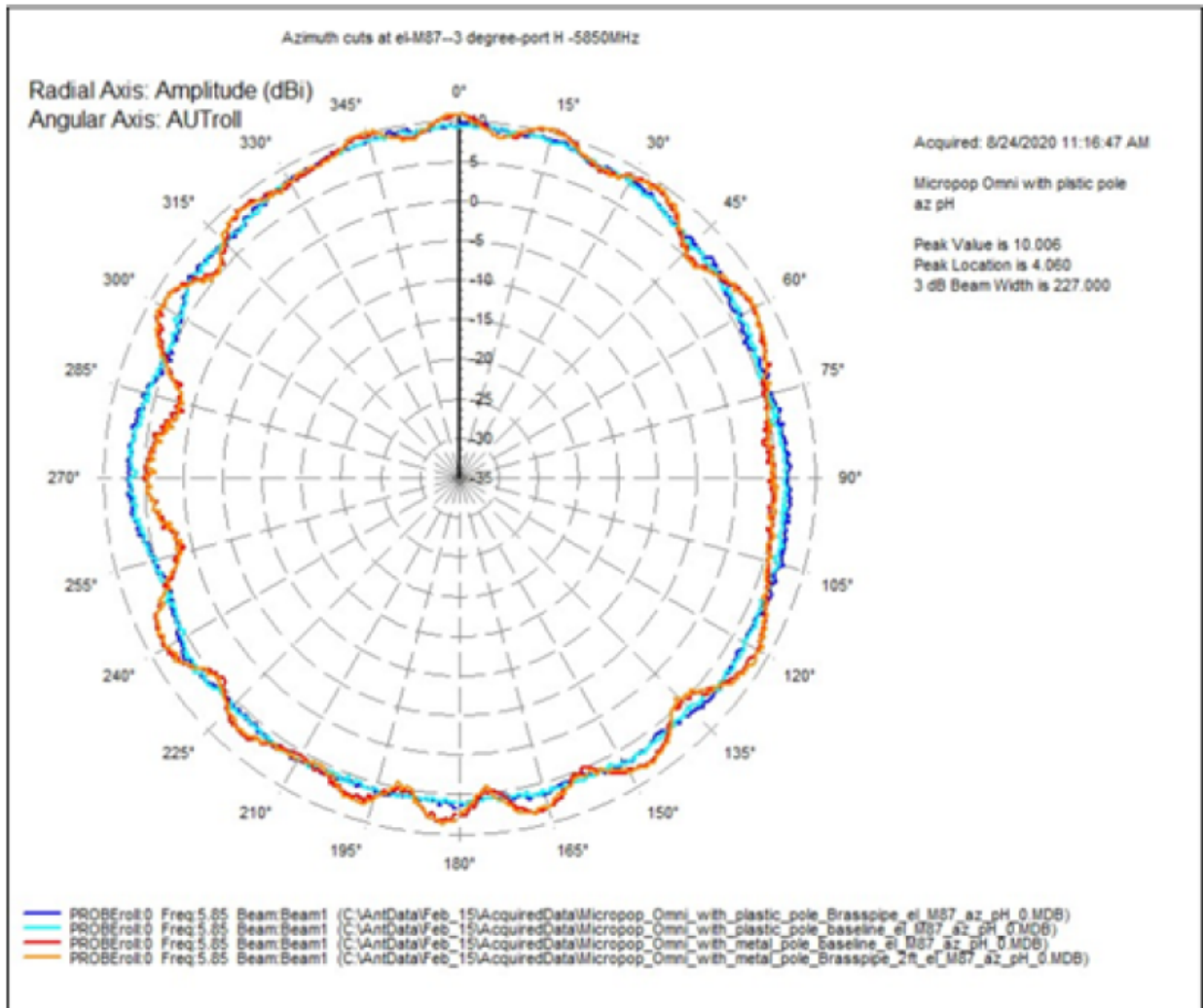

Figure 40: MicroPoP Omni antenna implementation pattern (Vertical)

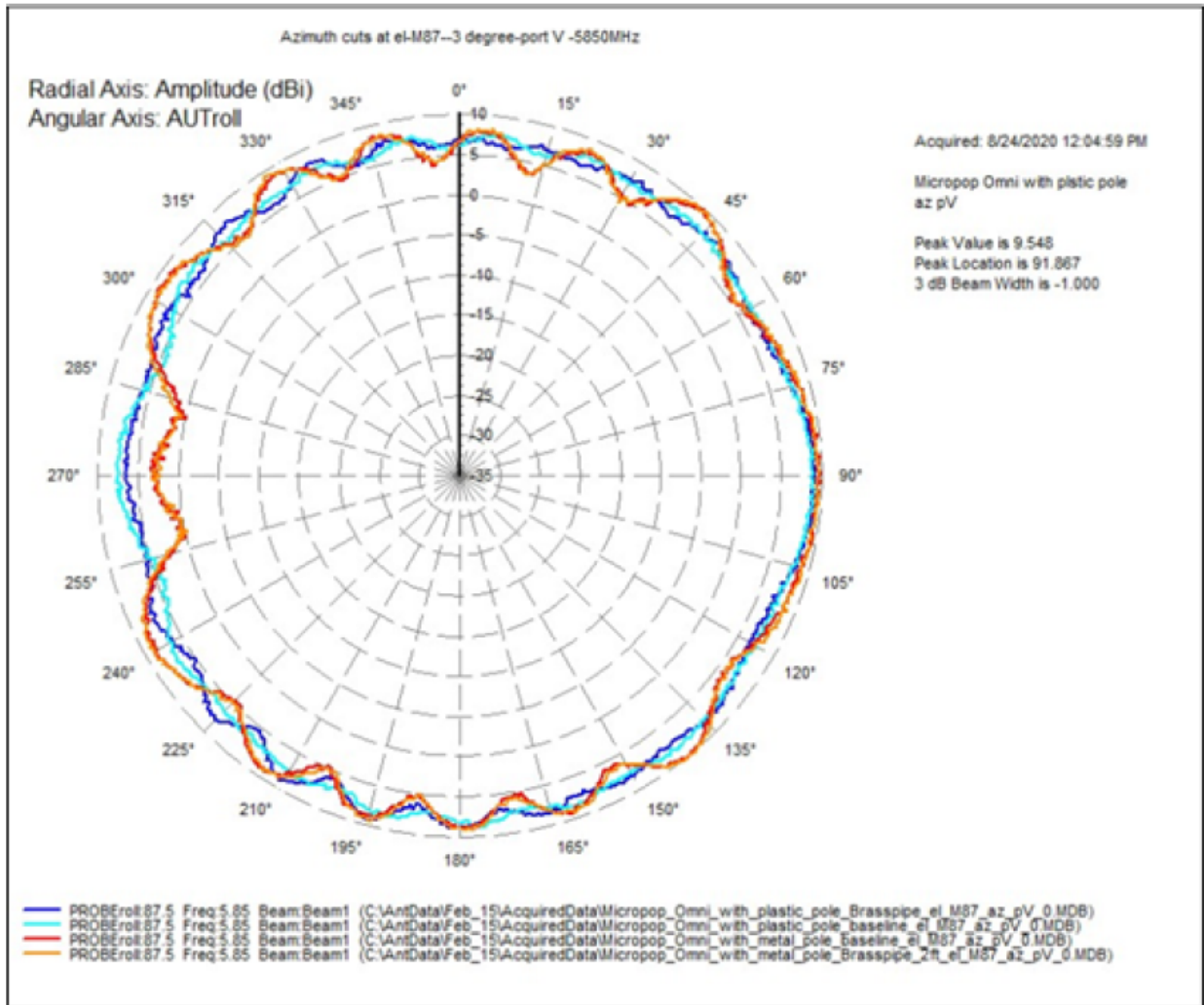
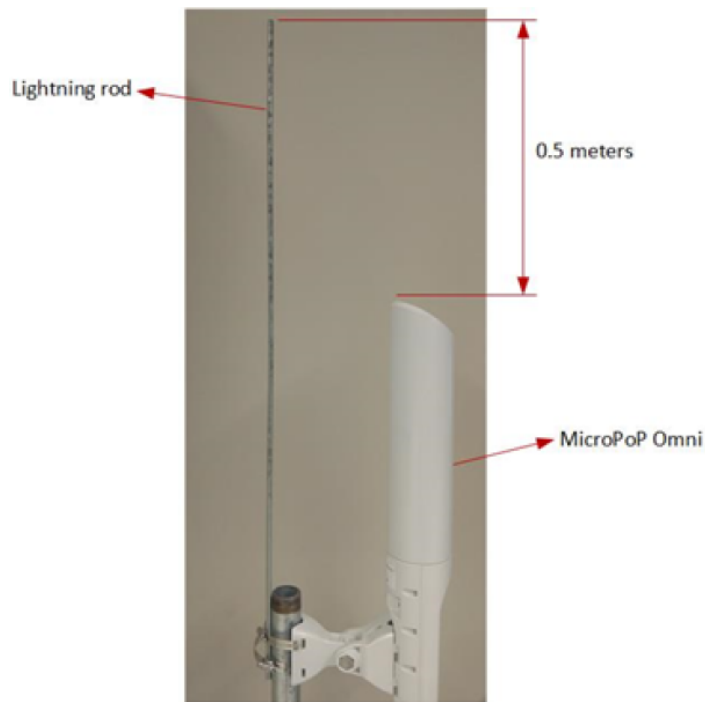

Figure 41: MicroPoP Omni with Lightning rod



Cabling

450b/450v Audio jack AUX Port synchronization cables

When the 450b is configured as a BHM and 450v SM can receive synchronization signals from either cnPulse or UGPS. The cnPulse/UGPS unit provides 1PPS (One Pulse Per Second) from its AUX output, which is connected to the Audio Jack AUX port of the 450b/450v.



Note

Aux port can also be configured to provide Sync out.

Cambium Networks provides a dedicated 3-meter accessory cable, N000000127A, designed for use with cnPulse. If a longer cable is needed, it is recommended to acquire a shielded outdoor 4-core cable and follow the wiring instructions provided in the table.

Table 75: Connections for cnPulse to 450b/450v Audio Jack Aux port

cnPulse RJ45 pin	3.5 mm TRRS jack	Signal description
4	Ring 1	GPS power out (+5 V DC)
5	Ring 2	GPS serial data in

cnPulse RJ45 pin	3.5 mm TRRS jack	Signal description
7	Shield/Ground	GPS 0 V (return)
8	Tip	GPS Sync in (1PPS)

Table 76: Connections for UGPS to 450b/450v Audio Jack Aux port

UGPS RJ11 pin	3.5 mm TRRS jack	Signal description
1	Tip	GPS Sync in (1PPS)
3	Ring 2	GPS serial data in
4	Ring 1	GPS power out (+5 V DC)
6	Shield/Ground	GPS 0 V (return)

For PMP 450b6, the AFC functionality requires the use of a certified external GPS receiver. For detailed installation instructions, please refer to the [GPS Synchronisation for PMP 450b6](#) section.

Ethernet standards and cable lengths

All configurations require a copper Ethernet connection from the ODU (Main PSU port) to the power supply.

Table 77: PSU drop cable length restrictions

System configuration		Maximum cable length (m/ft)	
Power supply	PoE powered device on AUX/SYNC port	From power supply to ODU	From ODU to PoE device on AUX/SYNC port
Power supply (30 W)	None	100 m	N/A
	IEEE 802.3at Type 2	Not supported	
AC Power Injector (60 W)	None	100 m	N/A
	IEEE 802.3at Type 2	100 m in total	
AC+DC enhanced power Injector	None	100 m	N/A
	IEEE 802.3at Type 2	100 m in total	
-48 V DC power injector	None	100 m	N/A
	IEEE 802.3at Type 2	100 m in total	
CMM4/CMM5 with 56 V supply	None	100 m	N/A
	IEEE 802.3at Type 2	Not supported	
IEEE 802.3at compliant supply	None	100 m	N/A
	IEEE 802.3at Type 2	Not supported	



Note

The Ethernet connectivity for CMM4/CMM5 requires the part **Ethernet cable adapter for CMM4/CMM5 – N000045L001A**.

Outdoor copper Cat5e Ethernet cable

Outdoor Cat5e cable is utilized for all connections that terminate outside the building. These connections include the ODU, surge suppressors, UGPS receivers, and the power supply injector. This type of cable is commonly referred to as an outdoor drop cable.

The following practices are essential to the reliability and longevity of cabled connections:

- Use only shielded cables and connectors to resist interference and corrosion.
- For vertical runs, provide cable support and strain relief.
- Include a 2 ft (0.6 m) service loop on each end of the cable to allow for thermal expansion and contraction, and to facilitate terminating the cable again when needed.
- Include a drip loop to shed water so that most of the water does not reach the connector at the device.
- Properly crimp all connectors.
- Use dielectric grease on all connectors to resist corrosion.

Order Superior Essex type BBDGe cable from Cambium Networks ([Table 78](#)). Other lengths of this cable are available from Superior Essex.

Figure 42: Outdoor drop cable

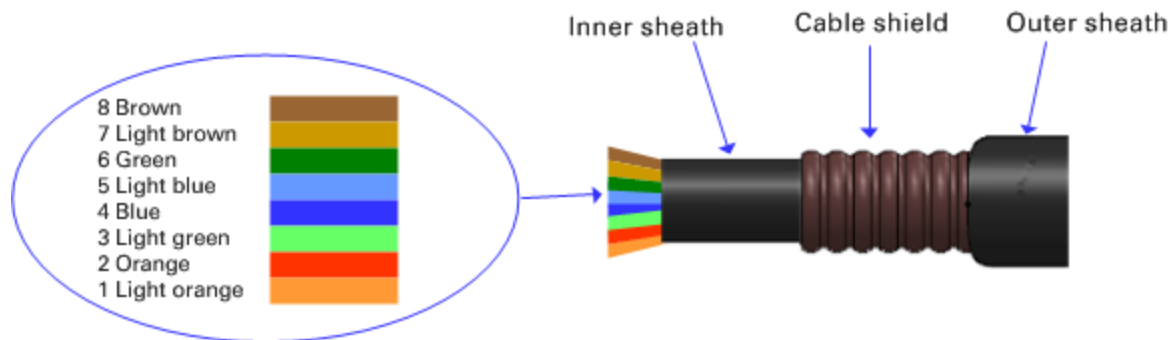

Table 78: Drop cable part numbers

Cambium description	Cambium part number
1000 ft reel outdoor copper-clad Cat5e	WB3175
328 ft (100 m) reel outdoor copper-clad Cat5e	WB3176

SFP module kits

SFP module kits enable the connection of a PMP 450 Series ODU to a network through an optical Gigabit Ethernet interface, supporting 1000BASE-LX or 1000BASE-SX in full-duplex mode.



Note

PMP 450m supports Fiber SFPs from System Release 15.0.3.

Order SFP module kits from Cambium Networks ([Table 79](#)).

Table 79: SFP module kit part numbers

Cambium description	Cambium part number
Single mode optical SFP interface per ODU 1G	SFP-1G-LX*
Multi-mode optical SFP interface per ODU 1G	SFP-1G-SX
10G SFP+ SMF LR Transceiver	SFP-10G-LR
10G SFP+ MMF SR Transceiver	SFP-10G-SR

* Cambium-branded single-mode optical SFP is suitable for 5 GHz 450m APs but is not recommended for 3 GHz 450m APs. Cambium recommends using Cambium-branded MMF modules for 3 GHz 450m APs. If SMF is absolutely required, a suggested third-party option is:

- Solid Optics SFP-1G-LX-SO

PoE Cable Pinout

Main Ethernet port

The PoE cable pinout interface for Main port is given in [Table 80](#).

Table 80: Main port PoE cable pinout

RJ45 pin	Interface	Ethernet description	PoE input description
1	1000BASE-T Ethernet with PoE In	+TxRx0	+Ve or -Ve
2		-TxRx0	
3		+TxRx1	+Ve or -Ve
6		-TxRx1	
4		+TxRx2	+Ve or -Ve
5		-TxRx2	
7		+TxRx3	+Ve or -Ve
8		-TxRx3	



Note

The PoE input on the Main port accepts any polarity.

AUX Ethernet port (450v, 450m)

The PoE cable pinout interface for AUX port is given in [Table 81](#).

Table 81: AUX port PoE cable pinout

RJ45 pin	Interface	Ethernet description	PoE Out description
1	1000BASE-T Ethernet with PoE In	+TxRx0	+Ve
2		-TxRx0	
3		+TxRx1	-Ve
6		-TxRx1	
4		+TxRx2	Data only
5		-TxRx2	
7		+TxRx3	Data only
8		-TxRx3	



Note

The PoE output on the AUX port provides power on 1, 2 (+Ve) and 3, 6 (-Ve) polarity.

Aux port on 450i

Table 82: Aux port PoE cable pinout

RJ45 pin	Interface	Signal description	PoE output description
1	100BASE-T Ethernet with PoE Out	+TxRx0	-Ve
2		-TxRx0	
3		+TxRx1	+Ve
6		-TxRx1	
4	GPS and alignment tone	GPS power out, Alignment tone out, GPS data out	N/A
5		GPS data in	
7		GPS 0 V	
8		GPS Sync in	



Note

When utilizing the Aux port, it is necessary to order a second Ethernet gland (Part number: N000065L033A).

Aux port to alignment tone headset wiring

To utilize the audio alignment tool, you can connect a standard 32 ohm stereo headset to the Aux port. The diagrams for the adapters corresponding to RJ45 and RJ12 connections can be found in [Figure 43](#) and [Figure 44](#) respectively. For optimal performance, it is recommended to use resistors with values of 220 ohm and 0.25 W. However, different resistor values can be used to optimize the audio signal level based on the characteristics of the headset and the ambient noise level.

Figure 43: Alignment tone cable

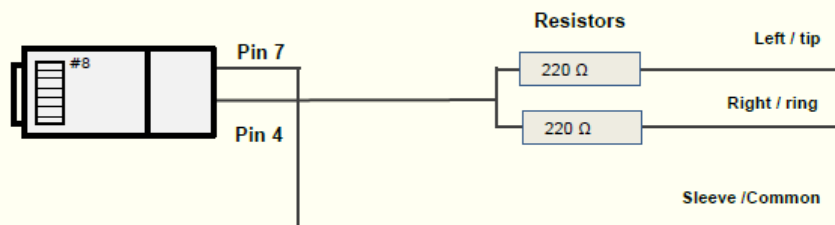

Table 83: Aux port PoE cable pinout

RJ45 pin (Aux port)	Signal description	Serial component	Jack socket (to jack plug of headset)
4	Alignment tone out	220 ohm resistor	Ring
		220 ohm resistor	Tip
7	GPS 0 V	None	Sleeve

Figure 44: RJ12 Alignment Tone Cable

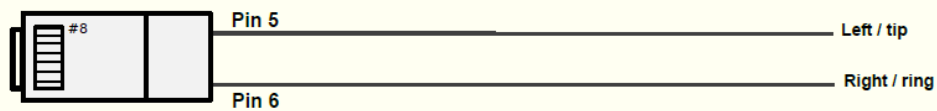

Table 84: RJ12 Aux port PoE cable pinout

RJ12 pin (Aux port)	Signal description	Jack socket (to jack plug of headset)
5	Alignment tone out	Tip
6	Alignment tone out	Ring

Alternatively, a readymade headset adapter can be ordered from Best-Tronics (<http://btpa.com/Cambium-Products/>) with the following part numbers:

Table 85: Alignment tone adapter third party product details

Reference	Product description
BT-1277	Headset alignment cable (RJ45) for the PMP/PTP 450i Series products
BT-0674	Headset alignment cable (RJ12) for the PMP/PTP 450 Series products

RJ45 connectors and spare glands

RJ45 connectors are required for plugging Cat5e cables into ODUs, LPUs, PSUs, and other devices. Order RJ45 connectors and crimp tool from Cambium Networks.

The ODU for 5 GHz 450m is supplied with one environmental sealing gland and 3 GHz 450m is supplied with two sealing glands for the drop cable. This gland is suitable for cable diameters from 5 mm to 9 mm.

- Tighten the gland body into the radio enclosure with a torque of 5 Nm (3.69 lb-ft).



Caution

To prevent damage to the drop cable, ensure that the cable remains stationary while tightening the sealing cap of the cable gland.

- Tighten the sealing cap into the gland body until the rubber inside the cap starts to bulge outwards.

Figure 45: Cable gland



Table 86: RJ45 connector and spare gland part numbers

Cambium description	Cambium part number
Tyco/AMP, Mod Plug RJ45, 100 pack	WB3177
Tyco/AMP Crimp Tool	WB3211
RJ45 spare grounding gland - PG16 size (Qty. 10)	N000065L033

Breather Vent

- A breather vent is required for plugging into the spare ports of the ODUs.
- Identify the spare port and remove the black sealing cap from the ODUs.
- Install the breather vent screw head into the spare port with a torque of 5 Nm (3.69 lb-ft).

Figure 46: Breather vent



Table 87: Breather vent part number

Cambium description	Cambium part number
Breather Vent - PG16 size (Qty. 10)	N000000L141A

Ethernet cable testing

This section describes the procedure for testing the RJ45 Ethernet cables used for Main and Aux port connectivity on 450i and 450m radios.

To test a cable, perform the following instructions:

1. Check the resistances of the cable and radio installation using a digital multimeter (DMM).
2. Disconnect the drop cable from the power source (EPI or mains adapter) first; keep the radio connected and test the resistances looking towards the radio. Test access can be made via any of the following:
 - Directly onto the pins of the RJ45 plug
 - Using a commercially available RJ45 breakout board

Measure between	Approximate resistance	Example
Wire 1 and wire 2 Wire 3 and wire 6 Wire 4 and wire 5 Wire 7 and wire 8	1 ohm + 2 ohm per 10 m of cable Maximum difference between any two readings: 0.3 ohm + 0.3 ohm per 10 m of cable A cable with a single LPU but no radio reads about 3,600 ohm. A cable with a single 1000SS but no radio reads about 7,200 ohm.	For a 20m cable: Approximate resistance = 1 ohm + 2x 2 ohm = 5 ohm Maximum difference between readings = 0.3 ohm + 2x 0.3 ohm = 0.9 ohm
Wire 1 and wire 3 Wire 1 and wire 4 Wire 1 and wire 7 Wire 3 and wire 4	> 20 Kohm	

Measure between	Approximate resistance	Example
Wire 3 and wire 7		
Wire 4 and wire 7		





Note
 These figures must be indicative only rather than hard limits. The measurement must be done with a low-voltage DMM, not a high-voltage insulation tester.

Lightning protection unit (LPU) and grounding kit

PMP 450i and PMP 450m Series LPUs offer transient voltage surge suppression for ODU installations. Two LPUs are required for each cable, with one positioned near the ODU and the other near the connected device, typically at the building entry point.

Table 88: LPU and grounding kit contents

<p>Lightning protection units (LPUs) LPU grounding point nuts and washers</p> 	<p>ODU to top LPU drop cable (600 mm) EMC strain relief cable glands</p> 
<p>U-bolts, nuts and washers for mounting LPUs</p>	<p>ODU to top LPU ground cable (M6-M6)</p>

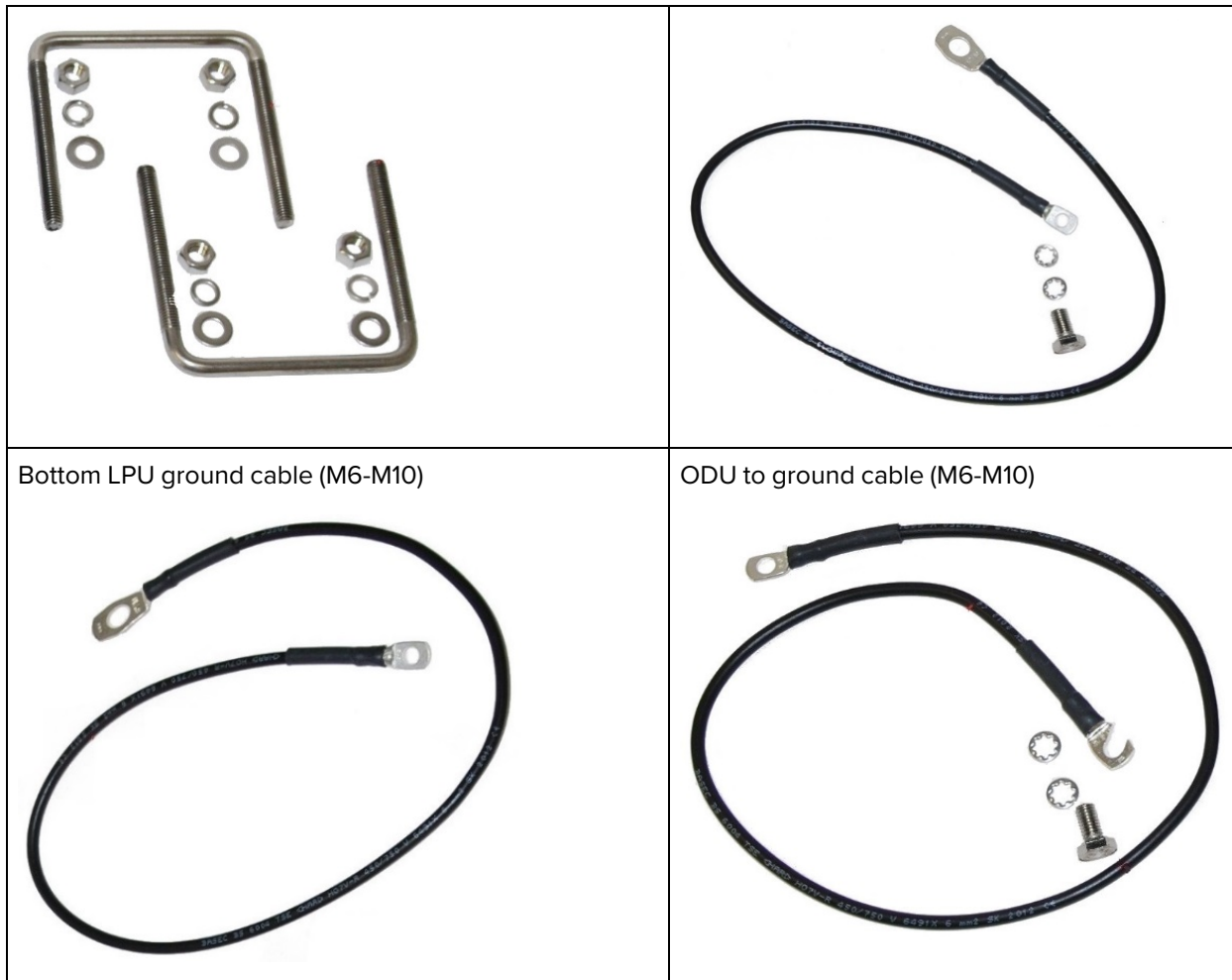

Bottom LPU ground cable (M6-M10)

ODU to ground cable (M6-M10)

For the connection of the PSU drop cable to the ODU, one LPU and grounding kit (referring to LPU and grounding kit contents) are necessary. If there is a requirement to connect the ODU to an auxiliary device, an additional LPU and grounding kit are needed for the Aux drop cable. Kindly place an order for the kits from Cambium Networks, specifying the LPU and grounding kit part number.

Table 89: LPU and grounding kit part number





Cambium description	Cambium part number
Aux ports LPU and Grounding Kit (One Kit Per End)	C000065L007B

When utilizing LPUs on the Ethernet ports of the 3 GHz PMP 450m, it is essential to employ a separate PoE power supply at the bottom of the mast to forward bias the diodes in the LPUs. This power supply should be positioned in the same manner as utilized in a PoE Ethernet port. Failure to adhere to this requirement may result in the occurrence of CRC errors on the Ethernet interface.

DC LPU and grounding kit

PMP 450m 3 GHz LPUs offer transient voltage surge suppression for ODU installations. For each cable, it is necessary to have two LPUs, one positioned near the ODU and the other placed near the linked device, typically at the building entry point.

Table 90: DC LPU and grounding kit contents

<p>LPUs LPU grounding point nuts and washers</p> 	<p>EMC strain relief cable glands</p> 
<p>U-bolts, nuts and washers for mounting LPUs</p> 	<p>ODU to top LPU ground cable (M6-M6), bolt and washers</p> 
<p>ODU to grounding system ground cable, bottom LPU ground cable (2pcs, M6 and M10 lugs), bolt and washers</p>	<p>4-pin connector kits (4 kits, one is shown below)</p>

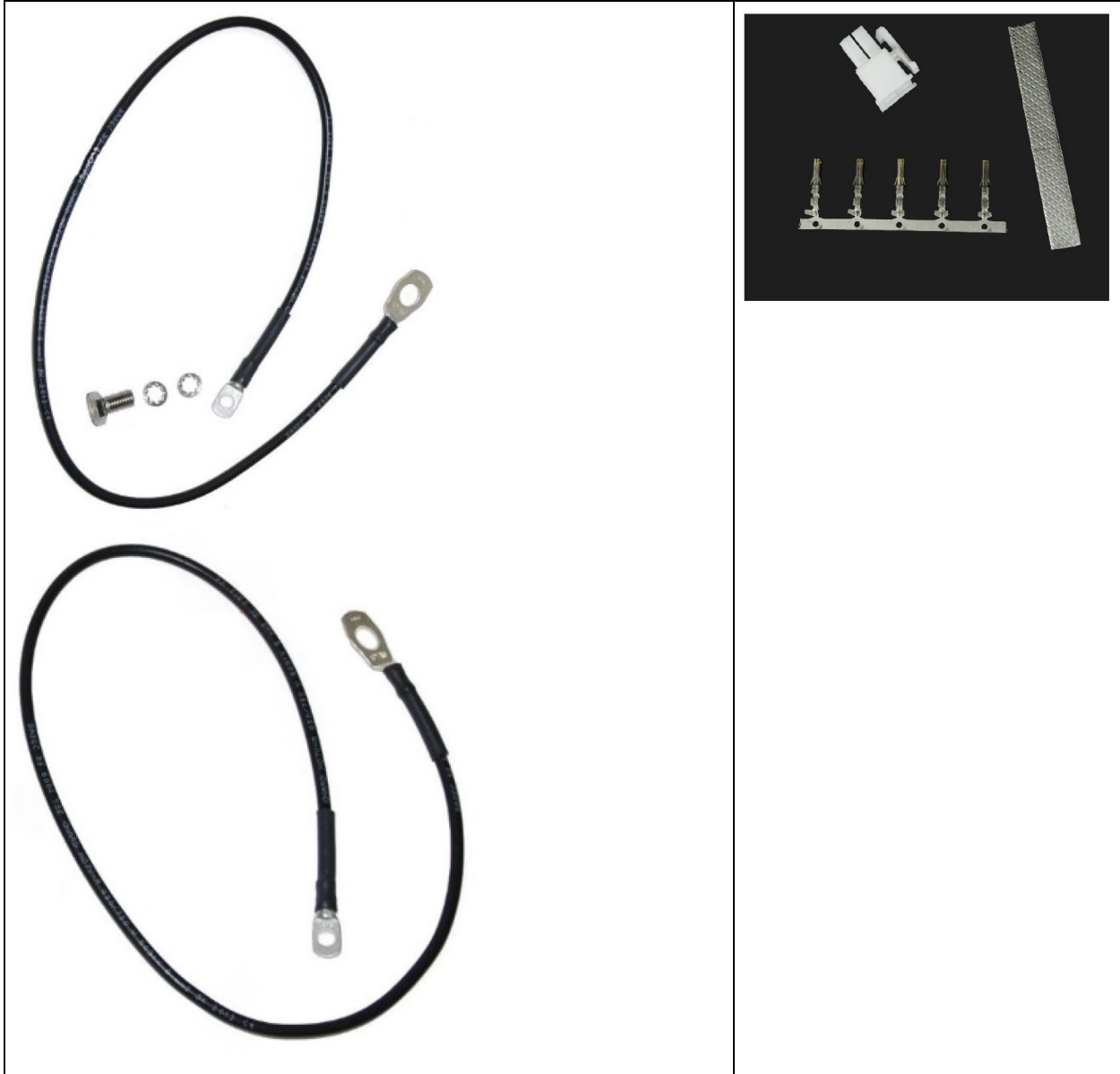

One LPU and grounding kit ([LPU and grounding kit contents](#)) is required for the PSU drop cable connection to the ODU. If the ODU is to be connected to an auxiliary device, one additional LPU and grounding kit is required for the Aux drop cable. Order the kits from Cambium Network ([DC LPU and grounding kit part number](#)).



Note

During the installation of LPUs, it is important to exclusively utilize EMC cable glands provided in the ODU and LPU kits, identifiable by their black caps. Non-EMC cable glands supplied in other kits, distinguished by their silver caps, should not be used as they are intended solely for ODU installations without LPUs.



Caution

To ensure sufficient protection, it is necessary for all grounding cables to have a minimum size of 10 mm² CSA (8 AWG), preferably 16 mm² CSA (6AWG), or 25 mm² CSA (4AWG).

Table 91: DC LPU and grounding kit part number

Cambium description	Cambium part number
DC LPU and Grounding Kit	C000000L114A

Cable grounding kit

In order to prevent lightning strike arcing, the copper drop cable shields must be bonded to the grounding system. This is crucial to mitigate fire risks and protect the equipment from damage.

For each grounding point on the cable, it is necessary to have one grounding kit, specifically the cable grounding kit. You can order the cable grounding kits from Cambium Networks using the LPU and grounding kit part number.

Figure 47: Cable grounding kit



Table 92: Cable grounding kit part numbers

Cambium description	Cambium part number
Cable grounding kits For 1/4" and 3/8" cable	01010419001

Antennas and antenna cabling

Antenna requirements

Each Connectorized ODU necessitates the use of one external antenna, typically a dual-polar antenna.

When operating Connectorized units within the USA or Canada in the 900 MHz, 4.9 GHz, 5.1 GHz, 5.2 GHz, 5.4 GHz, or 5.8 GHz bands, it is advised to select external antennas that are specifically recommended by Cambium Networks. Installing any other antennas is not recommended.

Supported AP external antennas

The recommended AP external antennas are listed in [Table 93](#).

Table 93: List of AP external antennas

Cambium description	Cambium part number
900 MHz 13 dBi 65 degree sector antenna (Dual slant)	N009045D001A
5 GHz horizontal and vertical polarization antenna for 90 degree sector	85009324001
5 GHz horizontal and vertical polarization antenna for 60 degree sector	85009325001



Note

The LINKPlanner, a planning tool offered by Cambium Networks, provides an extensive and comprehensive list of antennas that are compatible with Cambium Products.

Supported external BH/SM antenna

The appropriate external antenna for the PTP 450i Series BH or PMP 450/450i Series SM is specified in the PTP 450i Series BH or PMP 450/450i Series SM external antenna documentation.

Table 94: PTP 450i Series BH or PMP 450/450i Series SM external antenna

Cambium description	Cambium part number
900 MHz 12 dBi gain directional antenna (dual slant)	N009045D003A

RF cable and connectors

To connect the ODU to the antenna, an RF cable of the generic type LMR-400 is necessary. N type male connectors should be used to establish the connection between the RF cables and the connectorized ODU. Each ODU requires two connectors. It is advisable to opt for weatherproof connectors, preferably those equipped with adhesive-lined heat shrink sleeves, to ensure a secure and reliable interface between the cable and the connector. You can conveniently order the CNT-400 RF cable and N type male connectors from Cambium Networks (RF cable and connector part numbers).

Table 95: RF cable and connector part numbers

Cambium description	Cambium part number
50 Ohm Braided Coaxial Cable - 75 meter	30010194001
50 Ohm Braided Coaxial Cable - 500 meter	30010195001
RF Connector, N, Male, Straight for CNT-400 Cable	09010091001

Antenna accessories

Connectorized ODUs require the following additional components:

- Cable grounding kits: Order one cable grounding kit for each grounding point on the antenna cables.
- Self-amalgamating and PVC tape: Order these items to weatherproof the RF connectors
- Lightning arrestors: When mounting the connectorized ODU indoors, lightning arrestors (not LPUs) are necessary for protecting the antenna RF cables at the building entry. Each antenna cable requires one arrestor. An example of a compatible lightning arrestor is the Polyphaser LSXL-ME or LSXL (not supplied by Cambium Networks).

GPS synchronization

Cambium Networks offers GPS synchronization to mitigate self-interference within the network. The Cluster Management Module (CMM) delivers Global Positioning System (GPS) synchronization to both the AP and all associated SM. Network operators can choose between UGPS and CMM solutions to select the option that best suits their environment.

Universal GPS (UGPS)

The UGPS offers network synchronization for smaller networks where using a CMM may not be cost-effective. It provides synchronization for one or two modules, allowing even remote areas at the edge of the network to operate with synchronization, thereby improving performance. The UGPS is compatible with all Cambium PMP radios and boasts a small footprint, making it easy to deploy.

Figure 48: UGPS





Note

- In the PMP 450/450i/450m Series, APs have the capability to power up a UGPS through the Aux/Timing port.
- For the PMP 450i/450b/450m Series, if two units are to receive synchronization from the UGPS, an external power supply is necessary.
- If it is required to have the GPS position information visible on the web GUI, the UGPS power must be enabled on the AP. Additionally, it is safe to utilize both AP power and external power for a single UGPS unit.

Cluster Management Module (CMM5)

CMM5 represents the latest generation of solutions for the distribution of TDD sync signals and PoE in the field. It features a modular design, consisting of individual 4-port power injectors, and offers an optional controller for remote management.

Key features of the CMM5 include:

- Support for Gigabit Ethernet (1000BaseT)
- Modular and scalable from 4 ports to 32 ports
- Direct +/- 48 V DC input (optional AC/DC power supplies are available from Cambium Networks)
- Uses Cambium Networks UGPS for a synchronization source
- Dual resilient power inputs
- Rack mountable
- Secure remote management when used with the optional CMM5 Controller Module
- Support for PMP 450m (cnMedusa™)
- Future support for integration into cnMedusa™ for cloud or NOC-based management

It consists of four subsystems, described in the following sections:

- CMM5 controller module
- CMM5 injector (29 V and 56 V versions)
- Power supply (s) (240/600 watt)
- UGPS

Cluster Management: Scenario 1

Table 96 illustrates a CMM5 Cluster management scenario using four PMP 450i APs.

Table 96: CMM5 Cluster management Scenario 1

Scenario	Equipment Needed	Features
Four PMP 450i APs	56 V injector	<ul style="list-style-type: none"> Gigabit Ethernet Local management interface +/- 48 V DC input Broad device support Rack mountable
<ul style="list-style-type: none"> 48 V DC Available No management or resilience required 	UGPS	-

Figure 49: Cluster management: Scenario 1

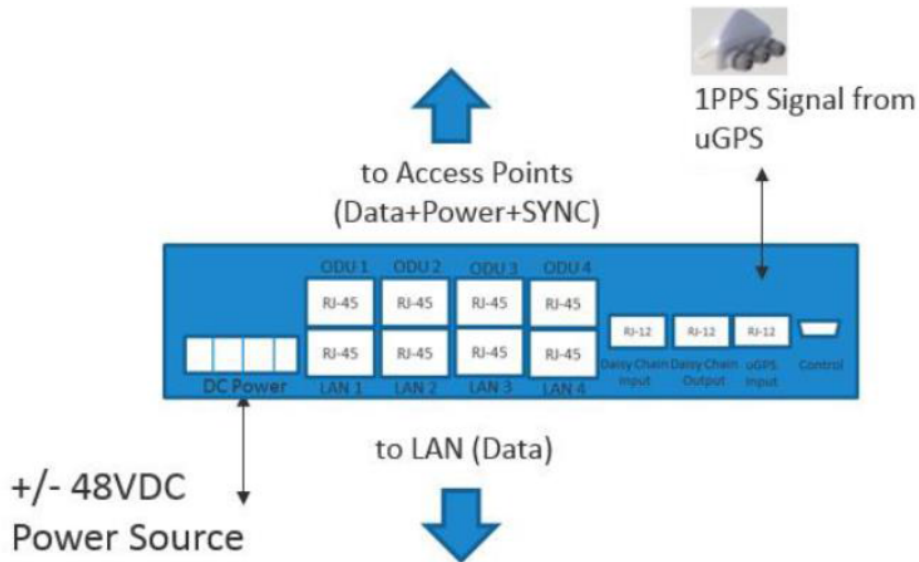

Cluster management: Scenario 2

Table 97 illustrates a CMM5 Cluster Management scenario that includes four PMP 450i APs and four PMP 450 APs.

Table 97: CMM5 cluster management scenario 2

Scenario	Equipment Needed	Features
Four PMP 450i APs Four PMP 450 APs	<ul style="list-style-type: none"> • 56 V injector • 29 V injector • 1 CMM5 controller • One UGPS 	<ul style="list-style-type: none"> • Gigabit Ethernet support • Local management interface • +/- 48 V DC Input • Broad Device Support • Rack Mountable
AC only environments	Two UGPS AC-to-48 V DC power supplies	Resilient power sources
Management required	-	Secure, remote management (https)
Resilience required	-	Scalable upto 32 devices

Figure 50: Cluster Management: Scenario 2

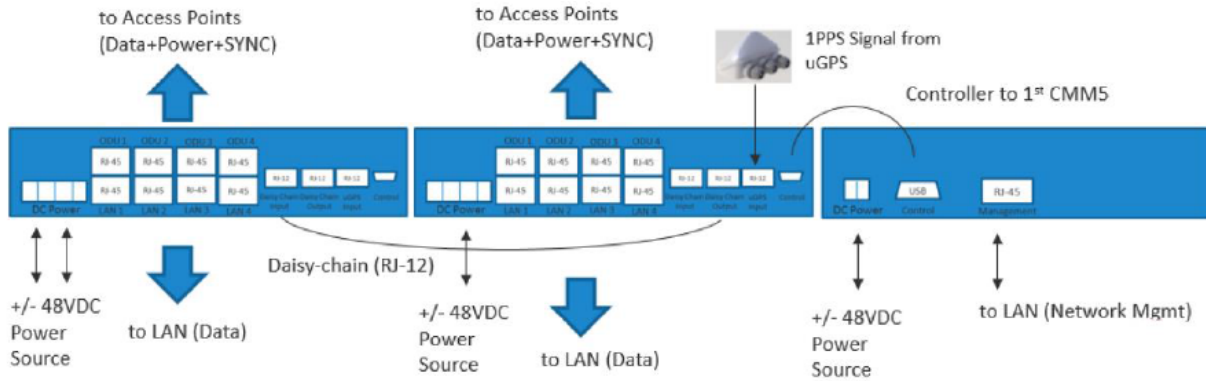

CMM5 Controller module

The major features of the CMM5 Controller Module are:

- Auto-detect/control up to 8 power injectors
- Monitor SYNC/Power/GPS status
- Manage (up/down ports)
- Web (HTTPS) and SNMPv2/v3 management (SNMP on roadmap)
- 1U/ half-width rack-mount

Figure 51: Controller Module



CMM5 injector module

The CMM5 injector module has the following features:

- Standalone mode or used with controller for management.
- +/- 48 V DC input with green/amber LEDs for status
- Injects SYNC pulse from UGPS
- 2U/half-width rack-mount



Note

There are two different versions of the injector module: 56 V and 29 V. It is crucial to select the correct injector for the types of radios being powered. Both injectors use the same input power supplies and can be powered with +/- 48 V DC. However, the output power and SYNC signal type vary between the two injector types. 29 V and 56 V injectors can be deployed together within the same system.

Figure 52: Injector Module

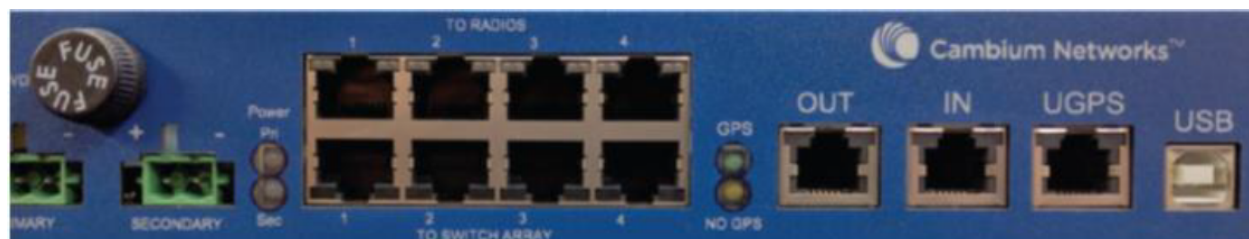

CMM5 injector compatibility matrix

Table 98 provides the Injector compatibility matrix.

Table 98: Injector compatibility matrix

Product	Power/Injector Module	Sync
PMP 450m	Yes/56 V	Yes
PMP/PTP 450i	Yes/56 V	Yes
PMP/ PTP 450b	Yes/29 V	Yes
PMP 450/PTP 450	Yes/29 V	Yes
PMP 100/PTP 100	Yes/29 V	Yes

CMM5 specifications

Table 99 provides specifications for the CMM5 power and sync injector (56 V).

Table 99: CMM5 specifications

CMM5 Power and Sync Injector 56 Volts	
Model number	C000000L556B
Data interface	4 each RJ45 Gigabit powered output ports To Radios 4 each RJ45 Gigabit data input ports To Switch Array 1 each GPS timing port (RJ-12) 1 each CMM5 USB serial port for local administration 1 each RJ12 daisy chain port IN 1 each RJ12 daisy chain port OUT
Surge suppression	Lightning suppression for each To Radios RJ45 Port
Power	Input voltage: + or - 48 V DC Input power consumption: 400 watts Output Voltage: + or - 55 V DC Output Current: 0 - 1.8 A per channel Output Power: 0 - 90 Watts per channel
Cabinet temperature	-40° C to +55° C (-40° F to +131° F), 90% humidity, condensing
Physical	Maximum distance from managed radios: 328 cable feet (100m) Maximum distance to GPS Antenna: 100 cable feet (30.5m)
Dimensions	8.85" W x 15.75" D x 1.65" H (225mm x 400mm x 42mm)
Unit weight	6.6 pounds (3kg)
Power interface terminals	Two power input ports for 48 V DC power (Power supplies sold separately)



Note

The DC Power Input requirement is +/- 48 V DC and must not exceed 100 V for surges. If surges above 100 V DC are anticipated, it is necessary to use a suitable in-line DC surge suppressor with a nominal voltage of 48 V DC.

CMM4/CMM5 (Rack mount)

The CMM serves as the heart of the Cambium system's synchronization capability, enabling network operators to reuse frequencies and add capacity while ensuring consistency in the quality of service to customers.

For operators who prefer indoor CMM mounting, Cambium offers the Rack-Mounted CMM4/CMM5. The unit is designed to mount onto a standard 19-inch telecommunications rack, allowing the Cambium CMM4/CMM5 to be co-located with other telecommunications equipment.

Figure 53: CMM4/CMM5 (Rack mount)

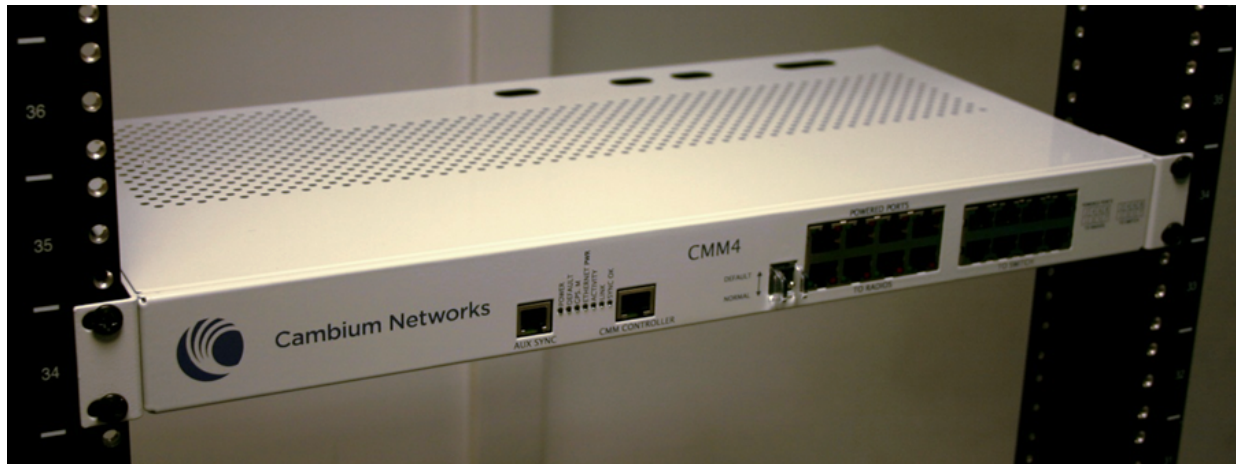

The CMM4/CMM5 is equipped with two DC power inputs: one operating at 29 V and the other at 56 V. It can efficiently power and synchronize both legacy 29 V products like the PMP 450 Series and 56 V products such as the PMP 450i Series simultaneously.

When connecting the 29 V legacy products to CMM4/CMM5, a 29 V power supply must be connected. Likewise, when connecting the 450i Series to CMM4/CMM5, a 56 V power supply is required. The CMM4/CMM5 supports redundancy by allowing the use of two 56 V power supplies and two 29 V power supplies.



Warning

The PMP 450i Series requires different wiring between the CMM4/CMM5 and the device. If a PMP 450 Series ODU is replaced by a PMP 450i Series, and the existing drop cable needs to be reused, the **Ethernet cable adapter for CMM4/CMM5 - N000045L001A** must be used between the CMM4/CMM5 and the existing drop cable.

Figure 54: CMM4/CMM5 56 V power adapter (dongle)



CMM4/CMM5 56 V power adapter cable pinout

Figure 55: CMM4/CMM5 power adapter cabling diagram

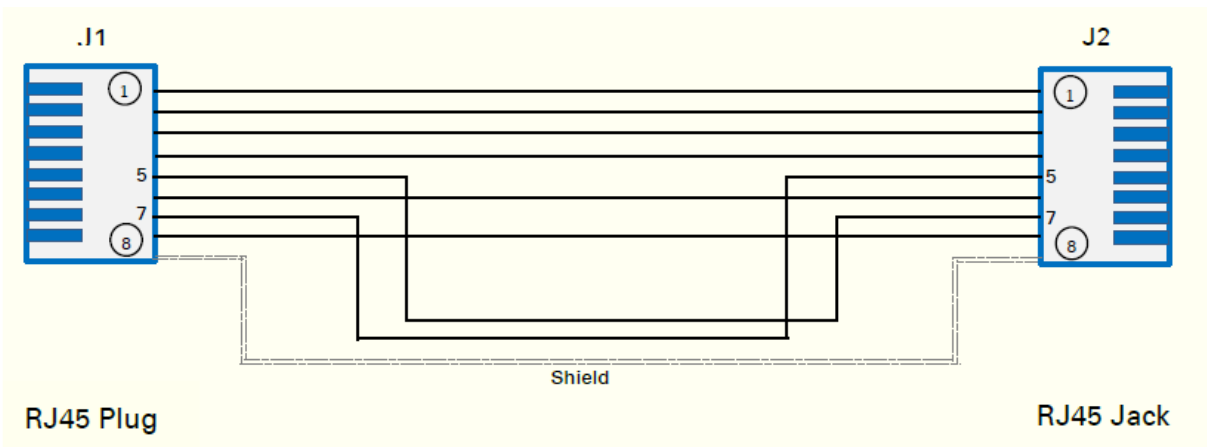

Table 100: CMM4/CMM5 power adapter cable pinout

Plug J1 pin	Jack J2 pin
1	1
2	2
3	3
4	4

Plug J1 pin	Jack J2 pin
5	7
6	6
7	5
8	8
Screen	Screen



Note

Pins 5 and 7 are wired in a cross-over configuration.

CMM4/CMM5 (Cabinet with switch)

The CMM4/CMM5, a cabinet with a switch, is designed to deliver consistent and reliable wireless broadband service. The PMP/PTP system gracefully scales to support large deployments. At the core of its synchronization capability lies the cluster management module, which enables network operators to re-use frequencies, add capacity, and maintain consistency in the quality of service provided to customers. As a result, subscribers can enjoy carrier-grade service even at the outer edge of the network.

Figure 56: CMM4/CMM5 (Cabinet with switch)



CMM4/CMM5 (Cabinet without switch)

The CMM4/CMM5 includes all the functionality listed above, except for a built-in switch. This design choice allows the network operator the flexibility to use their preferred switch while still benefiting from the power and synchronization capabilities of the CMM4/CMM5.

CMM3/CMMmicro

The CMM3 or CMMmicro provides power, GPS timing, and networking connections for an AP cluster. The CMM3 is configurable through a web interface.

The CMM3 features an 8-port managed switch that supports Cambium PoE, specifically designed for Cambium fixed wireless broadband IP networks. Each port can provide PoE and connect a combination of APs, BHMs, BHSs, or Ethernet feeds. It is important to note that Cambium PoE should not be mixed with the IEEE Standard 803.3af PoE.

The CMM3 has the capability to auto-negotiate speed to match inputs that are either 100BASE-TX or 10BASE-T, as well as full duplex or half duplex, when the connected device is set to auto-negotiate. Alternatively, these parameters can be manually set.

A CMM3 requires only one cable, terminating in an RJ45 connector, for each connected module to distribute:

- Ethernet signaling.
- The CMM3 can provide power to up to 8 co-located modules, including APs, BHMs, or BHSs. Through a web interface to the managed switch, ports can be enabled or disabled for power.
- The CMM3 synchronizes with APs and BHMs by receiving 1-pulse-per-second timing information from Global Positioning System (GPS) satellites through an included antenna. It then passes the timing pulse, embedded in the 24 V power, to the connected modules.

GPS status information is available at the CMM3, however:

- The CMM3 provides time and date information to BHMs and APs if the CMMmicro is operating on CMMmicro Release 2.1 or later and the AP/BHM is operating on System Release 4.2 or later. For more details, refer to the **Configuring Time Settings** section in the *Configuration Guide*.
- When the CMM3 operates on a release prior to CMMmicro Release 2.1 or when the AP/BHM operates on a release prior to System Release 4.2, the CMM3 does not provide time and date information to BHMs and APs.

A CMM3/CMMMicro is shown in [Figure 57](#) and [Figure 58](#)..

Figure 57: CMM3	Figure 58: Pole mounted CMM3
---------------------------------	--

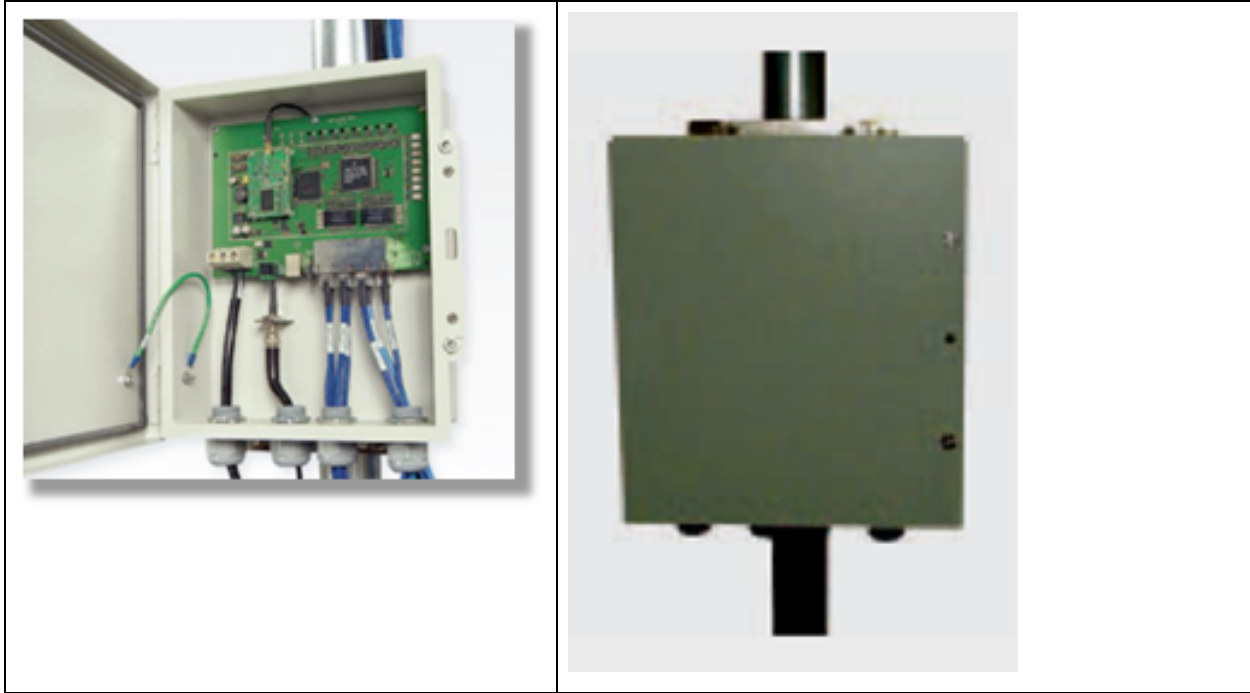

Note

A CMM3 cannot be used to power up a 450i or 450m Series ODUs.

GPS Synchronisation for PMP 450b6

The requirements of the Automatic Frequency Coordination (AFC) system for operating in the 6 GHz band mandate the use of a certified GPS Receiver to obtain latitude, longitude, and altitude parameters.

Supporting the AFC system, the 450b6 SM allows for the connection of an external GPS receiver via the 3.5mm Audio Jack Interface (N000045L004A: GPS puck kit for PMP 450b6).

Figure 59: External GPS



Installing a GPS receiver

To install a GPS receiver as the timing reference source, use the following procedures:

- Mounting the GPS receiver
- Cabling the GPS Antenna
- Installing and connecting the GPS LPU



Caution

Prior to powering up of equipment, ensure that all cables are connected to the correct interfaces of the CMM4/CMM5 unit and the UGPS receiver module. Failure to do so may result in damage to the equipment.

GPS receiver location

Mount the GPS receiver at a location that meets the following requirements:

- It must be possible to protect the installation as described in [Grounding and lightning protection](#).
- It must have an uninterrupted view of at least half of the southern (resp. northern) sky in the northern (resp. southern) hemisphere. For a receiver mounted on a wall there must be no other significant obstructions in the view of the sky.
- It must be mounted at least 1 m (3 ft), preferably 2 m (6 ft), away from other GPS receiving equipment.
- It must not be situated in the field of radiation of co-located radio communications equipment and should be positioned at a distance of at least 3 m (10 ft) away.

Mount the UGPS receiver on the wall of the equipment building if there is a suitable location on the wall that can meet these requirements.

Mounting the GPS receiver module on the equipment building

If mounting the GPS receiver on the equipment building ([GPS receiver wall installation](#)), select a position on the wall that meets the following requirements:

- It must be below the roof height of the equipment building or below the height of any roof-mounted equipment (such as air conditioning plant).
- It must be below the lightning air terminals.
- It must not project more than 600mm (24 inches) from the wall of the building.

If these requirements cannot all be met, then the module must be mounted on a metal tower or mast.

Mounting the GPS receiver module on a metal tower or mast

If mounting the GPS receiver module on a metal tower or mast ([GPS receiver tower or mast installation](#)), select a position that meets the following requirements:

- It must not be mounted any higher than is necessary to receive an adequate signal from four GPS satellites
- It must be protected by a nearby lightning air terminal that projects farther out from the tower than the GPS receiver module

Mounting the GPS receiver

To ensure proper installation of the GPS receiver, follow the manufacturer's instructions. You can mount the GPS receiver on either an external wall ([GPS receiver wall installation](#)) or a metal tower or mast ([GPS receiver tower or mast installation](#))

Figure 60: GPS antenna mounting

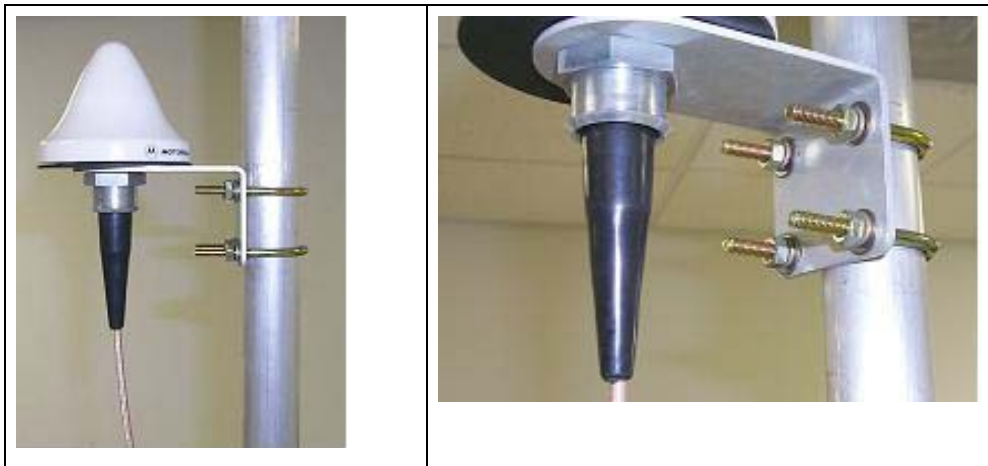

Procedure 1: Mounting the GPS receiver

1	<p>Ensure that the mounting position</p> <ul style="list-style-type: none">• has an unobstructed view of the sky to 20° above the horizon• is not the highest object at the site. (The GPS antenna does not need to be particularly high on a site, which would give it more exposure to lightning. It just needs to have an unobstructed view of the sky)• is not further than 100 feet (30.4 meters) of cable from the CMM
2	<p>Select a pole that has an outside diameter of 1.25 to 1.5 inches (3 to 4 cm) to which the GPS antenna bracket can be mounted.</p>

3	Place the U-bolts (provided) around the pole.
4	Slide the GPS antenna bracket onto the U-bolts.
5	Slide the ring washers (provided) onto the U-bolts.
6	Slide the lock washers (provided) onto the U-bolts.
7	Use the nuts (provided) to securely fasten the bracket to the U-bolts.

Please refer to the PMP Synchronization Solutions User Guide located on the Cambium website (<http://www.cambiumnetworks.com/resource/pmp-synchronization-solutions>).

Cabling the GPS Antenna

Connect the GPS coax cable to the female N-connector on the GPS antenna. Please refer to the PMP Synchronization Solutions User Guide located on the Cambium website (<http://www.cambiumnetworks.com/resource/pmp-synchronization-solutions>).

Installing and connecting the GPS LPU

Install and ground the GPS drop cable LPU at the building (or cabinet) entry point, as described in [Install the bottom LPU](#).

Installing GPS Module for PMP 450b6

To install the GPS module for the PMP 450b6 device, follow the below steps:

1. Use a nose plier to break the tab on the cover before connecting the 3.5mm audio jack cable from the GPS receiver to the 450b6 radio.



2. Ensure to connect the GPS module cable into the 3.5mm TRRS Audio Jack on the ODU.



3. Once the cable is secured, ensure that the GPS module is placed on the pole as shown in the below figure.



Ordering the components

This section describes how to select components for 450m Series, 450i Series and 450 Series Greenfield network or 450m/450i Series network migration. It specifies Cambium part numbers for 450 Platform Family components.

Order PMP 450m Series, PMP/PTP 450i Series and PMP/PTP 450 Series ODUs from Cambium Networks.

PMP 450m

Table 101: 3 GHz PMP 450m Series ODU part numbers

Cambium description	Superseded Sales SKU	Revised SKU suffix
3 GHz PMP 450m AP (Access Point)		
3 GHz PMP 450m Integrated Access Point, 90°	C030045A101A	C030045A101B
3 GHz PMP 450m Integrated Access Point, 90°	C030045A104A (No Encryption)	C030045A104B (No Encryption)
3 GHz PMP 450m Integrated Access Point, 90°	C030045A111A (Limited)	C030045A111B (Limited)
3 GHz PMP 450m Integrated Access Point, 90°	C030045A114A (Limited, No Encryption)	C030045A114B (Limited, No Encryption)

Table 102: 5 GHz PMP 450m Series ODU part numbers

Cambium description	Cambium part number
5 GHz PMP 450m AP (Access Point)	
5 GHz PMP 450m Integrated Access Point, 90° (ROW)	C050045A101A
5 GHz PMP 450m Integrated Access Point, 90° (FCC)	C050045A102A
5 GHz PMP 450m Integrated Access Point, 90° (EU)	C050045A103A
5 GHz PMP 450m Integrated Access Point, 90° (DES Only)	C050045A104A
5 GHz PMP 450m Integrated Access Point, 90° (IC)	C050045A105A
5 GHz PMP 450m Integrated Access Point, 90° (ROW)	C050045A111A (Limited)
5 GHz PMP 450m Integrated Access Point, 90° (FCC)	C050045A112A (Limited)
5 GHz PMP 450m Integrated Access Point, 90° (EU)	C050045A113A (Limited)

Cambium description	Cambium part number
5 GHz PMP 450m Integrated Access Point, 90° (DES Only)	C050045A114A (Limited)
5 GHz PMP 450m Integrated Access Point, 90° (IC)	C050045A115A (Limited)

PMP 450i

Table 103: PMP 450i Series ODU part numbers - Connectorized

Cambium description	Superseded Sales SKU	Revised SKU suffix
ODU model		
450i Connectorized	5085CHH	5085CJH
450i Integrated 90° sector	5082JH	5082KH
450i Integrated High Gain directional	5092JH	5092KH
450i Connectorized ATEX/HAZLOC - ATEX CONTROLLED ITEM	5085CHH	5085CJH
450i Integrated 90° sector ATEX/HAZLOC - ATEX CONTROLLED ITEM	5085HH	5085JH
450i Integrated High Gain Directional ATEX/HAZLOC - ATEX CONTROLLED ITEM	5095HH	5095JH
PMP 450i AP (Access Point)		
900 MHz PMP 450i Connectorized Access Point	C009045A001A	
3 GHz PMP 450i Connectorized Access Point	C030045A001A	
3 GHz PMP 450i Integrated Access Point, 90°	C030045A002A	
3 GHz PMP 450i Connectorized Access Point, DES Only	C030045A003A	
3 GHz PMP 450i Integrated Access Point, 90°, DES Only	C030045A004A	
5 GHz PMP 450i Connectorized Access Point (RoW)	C050045A001A*	C050045A001B**
5 GHz PMP 450i Connectorized Access Point (FCC)	C050045A002A*	C050045A002B**
5 GHz PMP 450i Connectorized Access Point (EU)	C050045A003A*	C050045A003B**
5 GHz PMP 450i Connectorized Access Point (DES Only)	C050045A004A*	C050045A004B**
5 GHz PMP 450i Connectorized Access Point (IC)	C050045A015A*	C050045A015B**
5 GHz PMP 450i AP, Integrated 90° sector antenna (RoW)	C050045A005A	
5 GHz PMP 450i AP, Integrated 90° sector antenna (FCC)	C050045A006A	

Cambium description	Superseded Sales SKU	Revised SKU suffix
5 GHz PMP 450i Integrated Access Point, 90° (EU)	C050045A007A	
5 GHz PMP 450i AP, Integrated 90° sector antenna (DES only)	C050045A008A	
5 GHz PMP 450i AP, Integrated 90° sector antenna (IC)	C050045A016A	
PMP 450i SM (Subscriber Module)		
3 GHz PMP 450i Connectorized Subscriber Module	C030045C001A	
3 GHz PMP 450i SM, Integrated High Gain Antenna	C030045C002A	
5 GHz PMP 450i Connectorized Subscriber Module	C050045C001A*	C050045C001B**
5 GHz PMP 450i SM, Integrated High Gain Antenna	C050045C002A	

* Previous model end (April 2019)

** Revised model starts (May 2019)



Note

The 450i SM does not have license keys.

Table 104: PMP 450i Integrated ODU models/part numbers

Cambium description	Superseded Sales SKU	Revised SKU suffix
ODU model		
450i Connectorized	5085CHH	5085CJH
450i Integrated 90° Sector	5082JH	5082KH
450i Integrated High Gain directional	5092JH	5092KH
450i Connectorized ATEX/HAZLOC - ATEX CONTROLLED ITEM	5085CHH	5085CJH
450i Integrated 90° sector ATEX/HAZLOC - ATEX CONTROLLED ITEM	5085HH	5085JH
450i Integrated High Gain Directional ATEX/HAZLOC - ATEX CONTROLLED ITEM	5095HH	5095JH
Part number		
5 GHz PMP 450i Connectorized Access Point (ROW), ATEX/HAZLOC	C050045A009A	C050045A009B

Cambium description	Superseded Sales SKU	Revised SKU suffix
5 GHz PMP 450i Connectorized Access Point (FCC), ATEX/HAZLOC	C050045A010A	C050045A010B
5 GHz PMP 450i Connectorized Access Point (EU), ATEX/HAZLOC	C050045A011A	C050045A011B
5 GHz PMP 450i Integrated Access Point, 90 degree (ROW), ATEX/HAZLOC	C050045A012A	C050045A012B
5 GHz PMP 450i Integrated Access Point, 90 degree (FCC), ATEX/HAZLOC	C050045A013A	C050045A013B
5 GHz PMP 450i Integrated Access Point, 90 degree (EU), ATEX/HAZLOC	C050045A014A	C050045A014B
5 GHz PMP 450i Connectorized Access Point (IC), ATEX/HAZLOC	C050045A017A	C050045A017B
5 GHz PMP 450i Integrated Access Point, 90° (IC), ATEX/HAZLOC	C050045A018A	C050045A018B
5 GHz PMP 450i Connectorized Access Point (DES Only), ATEX/HAZLOC	C050045A019A	C050045A019B
5 GHz PMP 450i Integrated Access Point, 90° (DES Only), ATEX/HAZLOC	C050045A020A	C050045A020B
5 GHz PMP 450i Connectorized Subscriber Module, ATEX/HAZLOC	C050045C003A	C050045C003B
5 GHz PMP 450i Integrated High Gain Antenna, ATEX/HAZLOC	C050045C004A	C050045C004B
5 GHz PMP 450i Integrated Access Point, 90° (ROW)	C050045A005B	C050045A005C
5 GHz PMP 450i Integrated Access Point, 90° (FCC)	C050045A006B	C050045A006C
5 GHz PMP 450i Integrated Access Point, 90° (EU)	C050045A007B	C050045A007C
5 GHz PMP 450i Integrated Access Point, 90° (DES Only)	C050045A008B	C050045A008C
5 GHz PMP 450i Integrated Access Point, 90° (IC)	C050045A016B	C050045A016C
5 GHz PMP 450i Integrated Narrow Beam Access Point, 10 degree (ROW)	C050045A049A	C050045A049B
5 GHz PMP 450i Subscriber Module, Integrated High Gain Antenna	C050045C002B	C050045C002C
5 GHz PMP 450i Integrated High Gain Antenna (Eolo)	C050045C009A	C050045C009B

PTP 450i

Table 105: PTP 450i Series – Con ODU part numbers

Cambium description	Superseded Sales SKU	Revised SKU suffix
450i Connectorized	5085CHH	5085CJH
450i Integrated 90° sector	5082JH	5082KH
450i Integrated High Gain directional	5092JH	5092KH
450i Connectorized ATEX/HAZLOC - ATEX CONTROLLED ITEM	5085CHH	5085CJH
450i Integrated 90° Sector ATEX/HAZLOC - ATEX CONTROLLED ITEM	5085HH	5085JH
450i Integrated High Gain directional ATEX/HAZLOC - ATEX CONTROLLED ITEM	5095HH	5095JH
3 GHz PTP 450i END, Connectorized	C030045B001A	
3 GHz PTP 450i END, Integrated High Gain Antenna	C030045B002A	
3 GHz PTP 450i END, Connectorized (DES only)	C030045B003A	
3 GHz PTP 450i END, Integrated Access Point, 90 degree (DES only)	C035045B004A	
5 GHz PTP 450i END, Connectorized (RoW)	C050045B001A*	C050045B001B**
5 GHz PTP 450i END, Connectorized (FCC)	C05004B003A*	C050045B003
5 GHz PTP 450i END, Connectorized (EU)	C050045B005A*	C050045B005B**
5 GHz PTP 450i END, Connectorized (DES only)	C050045B007A*	C050045B007B**
5 GHz PTP 450i END, Connectorized (IC)	C050045B015A*	C050045B015B**
5 GHz PTP 450i END, Integrated High Gain Antenna (RoW)	C050045B002A^	C050045B002B**
5 GHz PTP 450i END, Integrated High Gain Antenna (FCC)	C050045B004A	C050045B004B
5 GHz PTP 450i END, Integrated High Gain Antenna (EU)	C050045B006A	C050045B006B
5 GHz PTP 450i END, Integrated High Gain Antenna (DES only)	C050045B008A^	C050045B008B**
5 GHz PTP 450i END, Integrated High Gain Antenna (IC)	C050045B016A	C050045B016B
Ethernet cable adapter for CMM4/CMM5	N000045L001A	

* Previous model end (April 2019)

^ Previous model end (May 2019)

** Revised model starts (May 2019)

Table 106: PTP 450i Integrated models/part numbers

Cambium description	Superseded Sales SKU	Revised SKU suffix
ODU model		
450i Connectorized	5085CHH	5085CJH
450i Integrated 90° sector	5082JH	5082KH
450i Integrated High Gain directional	5092JH	5092KH
450i Connectorized ATEX/HAZLOC - ATEX CONTROLLED ITEM	5085CHH	5085CJH
450i Integrated 90° Sector ATEX/HAZLOC - ATEX CONTROLLED ITEM	5085HH	5085JH
450i Integrated High Gain directional ATEX/HAZLOC - ATEX CONTROLLED ITEM	5095HH	5095JH
5 GHz PTP 450i END, Connectorized (ROW), ATEX/HAZLOC	C050045B009A	C050045B009B
5 GHz PTP 450i END, Integrated High Gain Antenna (ROW), ATEX/HAZLOC	C050045B010A	C050045B010B
5 GHz PTP 450i END, Connectorized (FCC), ATEX/HAZLOC	C050045B011A	C050045B011B
5 GHz PTP 450i END, Integrated High Gain Antenna (FCC), ATEX/HAZLOC	C050045B012A	C050045B012B
5 GHz PTP 450i END, Connectorized (EU), ATEX/HAZLOC	C050045B013A	C050045B013B
5 GHz PTP 450i END, Integrated High Gain Antenna (EU), ATEX/HAZLOC	C050045B014A	C050045B014B
5 GHz PTP 450i END, Connectorized (IC), ATEX/HAZLOC	C050045B017A	C050045B017B
5 GHz PTP 450i END, Integrated High Gain antenna (IC), ATEX/HAZLOC	C050045B018A	C050045B018B
5 GHz PTP 450i END, Connectorized (DES Only), ATEX/HAZLOC	C050045B019A	C050045B019B
5 GHz PTP 450i END, Integrated High Gain Antenna (DES Only), ATEX/HAZLOC	C050045B020A	C050045B020B

PMP/PTP 450b

Table 107: PMP/PTP 450b Series ODU part numbers

Cambium description	Cambium part number
450b (PMP SM and PTP)	
5 GHz 450b - Mid-Gain – ROW	C050045B031A
5 GHz 450b - Mid-Gain – FCC	C050045B032A
5 GHz 450b - Mid-Gain – ISED	C050045B033A
5 GHz 450b - Mid-Gain – EU	C050045B034A
5 GHz 450b - Mid-Gain – No Encryption	C050045B035A
5 GHz 450b - High Gain – ROW – Radio Only	C050045B021A
5 GHz 450b - High Gain – FCC – Radio Only	C050045B022A
5 GHz 450b - High Gain – ISED – Radio Only	C050045B023A
5 GHz 450b - High Gain – EU – Radio Only	C050045B024A
5 GHz 450b - High Gain – No Encryption – Radio Only	C050045B025A
5 GHz 450b, 50 Mbps – High Gain – ROW – Radio Only	C050045B051A
5 GHz 4 Pack High Gain antenna assembly, IP55	N050045D002A
3 GHz 450b - High Gain – Radio Only	C030045B021A
3 GHz 450b - High Gain – No Encryption – Radio Only	C030045B025A
3 GHz High Gain antenna assembly, IP55 – 4-pack	N030045D001A
5 GHz 450b Retro - ROW	C050045B101A
5 GHz 450b Retro - FCC	C050045B102A
5 GHz 450b Retro - ISED	C050045B103A
5 GHz 450b Retro - EU	C050045B104A
5 GHz 450b Retro - No encryption	C050045B105A

PMP 450

Table 108: PMP 450 Series ODU part numbers

Cambium description	Cambium part number
PMP 450 AP (Access Point)	
2.4 GHz PMP 450 Connectorized Access Point	C024045A001A
2.4 GHz PMP 450 Connectorized Access Point (No Encryption)	C024045A003A
3.5 GHz PMP 450 Connectorized Access Point	C035045A001A
3.5 GHz PMP 450 Connectorized Access Point (No Encryption)	C035045A003A
3.6 GHz PMP 450 Connectorized Access Point	C036045A001A
3.6 GHz PMP 450 Connectorized Access Point (DES)	C036045A003A
PMP 450 AP Lite	
2.4 GHz PMP 450 Connectorized Access Point - Lite	C024045A011A
3.3-3.6 GHz PMP 450 Connectorized Access Point - Lite	C035045A011A
3.55-3.8 GHz PMP 450 Connectorized Access Point - Lite	C036045A011A
PMP 450 SM (Subscriber Module)	
900 MHz PMP 450 Connectorized Subscriber Module	C009045C001A
2.4 GHz PMP 450 Subscriber Module, 4 Mbps	C024045C001A
2.4 GHz PMP 450 Subscriber Module, 10 Mbps	C024045C002A
2.4 GHz PMP 450 Subscriber Module, 20 Mbps	C024045C003A
2.4 GHz PMP 450 Subscriber Module, uncapped	C024045C004A
2.4 GHz PMP 450 Connectorized Subscriber Module, 4 Mbps	C024045C005A
2.4 GHz PMP 450 Connectorized Subscriber Module, 10 Mbps	C024045C006A
2.4 GHz PMP 450 Connectorized Subscriber Module, 20 Mbps	C024045C007A
2.4 GHz PMP 450 Connectorized Subscriber Module, uncapped	C024045C008A
3.5 GHz PMP 450 High Gain directional integrated subscriber	C035045C014A
3.5 GHz PMP 450 Subscriber Module, 4 Mbps	C035045C001A
3.5 GHz PMP 450 Subscriber Module, 10 Mbps	C035045C002A

Cambium description	Cambium part number
3.5 GHz PMP 450 Subscriber Module, 20 Mbps	C035045C003A
3.5 GHz PMP 450 Subscriber Module, uncapped	C035045C004A
3.5 GHz PMP 450 Connectorized Subscriber Module, 4 Mbps	C035045C005A
3.5 GHz PMP 450 Connectorized Subscriber Module, 10 Mbps	C035045C006A
3.5 GHz PMP 450 Connectorized Subscriber Module, 20 Mbps	C035045C007A
3.5 GHz PMP 450 Connectorized Subscriber Module, uncapped	C035045C008A
3.6 GHz PMP 450 High Gain directional integrated subscriber	C036045C014A
3.6 GHz PMP 450 Subscriber Module, 4 Mbps	C036045C001A
3.6 GHz PMP 450 Subscriber Module, 10 Mbps	C036045C002A
3.6 GHz PMP 450 Subscriber Module, 20 Mbps	C036045C003A
3.6 GHz PMP 450 Subscriber Module, uncapped	C036045C004A
3.6 GHz PMP 450 Connectorized Subscriber Module, 4 Mbps	C036045C005A
3.6 GHz PMP 450 Connectorized Subscriber Module, 10 Mbps	C036045C006A
3.6 GHz PMP 450 Connectorized Subscriber Module, 20 Mbps	C036045C007A
3.6 GHz PMP 450 Connectorized Subscriber Module, uncapped	C036045C008A
5 GHz PMP 450 Integrated Subscriber Module, 4 Mbps	C054045C001B
5 GHz PMP 450 Integrated Subscriber Module, 10 Mbps	C054045C002B
5 GHz PMP 450 Integrated Subscriber Module, 20 Mbps	C054045C003B
5 GHz PMP 450 Integrated Subscriber Module, uncapped	C054045C004B
5 GHz PMP 450 Connectorized Subscriber Module, 4 Mbps	C054045C005B
5 GHz PMP 450 Connectorized Subscriber Module, 10 Mbps	C054045C006B
5 GHz PMP 450 Connectorized Subscriber Module, 20 Mbps	C054045C007B
5 GHz PMP 450 Connectorized Subscriber Module, uncapped	C054045C008B
5 GHz PMP 450d Subscriber Module, 20 Mbps – 4-pack	C054045H013B
5 GHz PMP 450d Subscriber Module, uncapped – 4-pack	C054045H014B

PMP 450 MicroPoP

Cambium description	Cambium part number
5 GHz 450 MicroPoP Omni - ROW	C050045A201A
5 GHz 450 MicroPoP Omni - FCC	C050045A202A
5 GHz 450 MicroPoP Omni - ISED	C050045A203A
5 GHz 450 MicroPoP Omni - EU	C050045A204A
5 GHz 450 MicroPoP Omni - No Encryption	C050045A205A
5 GHz 450 MicroPoP Sector - 90° - ROW	C050045A206A
5 GHz 450 MicroPoP Sector - 90° - FCC	C050045A207A
5 GHz 450 MicroPoP Sector - 90° - ISED	C050045A208A
5 GHz 450 MicroPoP Sector - 90° - EU	C050045A209A
5 GHz 450 MicroPoP Sector - 90° - No Encryption	C050045A210A
5 GHz 450 MicroPoP Connectorized - ROW	C050045A211A
5 GHz 450 MicroPoP Connectorized - FCC	C050045A212A
5 GHz 450 MicroPoP Connectorized - ISED	C050045A213A
5 GHz 450 MicroPoP Connectorized - EU	C050045A214A
5 GHz 450 MicroPoP Connectorized - No Encryption	C050045A215A
5 GHz 450b Connectorized - ROW	C050045B041A
5 GHz 450b Connectorized - FCC	C050045B042A
5 GHz 450b Connectorized - ISED	C050045B043A
5 GHz 450b Connectorized - EU	C050045B044A
5 GHz 450b Connectorized - No Encryption	C050045B045A

PTP 450

Table 109: PTP 450 Series ODU part numbers

Cambium description	Cambium part number
PTP 450 900 MHz END – Connectorized	C009045B001A
PTP 450 3.5 GHz END – Integrated	C035045B001A

Cambium description	Cambium part number
PTP 450 3.5 GHz END – Connectorized	C035045B002A
PTP 450 3.5 GHz END – Integrated – DES only	C035045B003A
PTP 450 3.5 GHz END – Connectorized – DES only	C035045B004A
PTP 450 3.65 GHz END – Integrated	C036045B001A
PTP 450 3.65 GHz END – Connectorized	C036045B002A
PTP 450 3.65 GHz END – Integrated – DES only	C036045B003A
PTP 450 3.65 GHz END – Connectorized – DES only	C036045B004A
PTP 450 5 GHz END – Integrated (ROW)	C054045B001A
PTP 450 5 GHz END – Connectorized (ROW)	C054045B002A
PTP 450 5 GHz END – Integrated (ROW) – DES only	C054045B003A
PTP 450 5 GHz END – Connectorized (ROW) – DES only	C054045B004A
PTP 450 5 GHz END – Integrated (FCC)	C054045B005A
PTP 450 5 GHz END – Connectorized (FCC)	C054045B006A

PMP/PTP 450/450i Series Accessories

Table 110: PMP/PTP 450/450i Series Accessories

Cambium description	Cambium part number
PMP 450 AP antenna options	
900 MHz 65° sector antenna (Dual slant)	N009045D001A
900 MHz 12 dBi gain directional antenna (Dual slant)	N009045D003A
2.4 GHz Dual slant antenna for 60° sector	C024045D601A
3.5 GHz and 3.6 GHz dual slant antenna for 90° sector	C030045D901A
5 GHz antenna for 60° sector	85009325001
5 GHz antenna for 90° sector	85009324001
N-type to N-type cable (16-inch length)	30009406002
Power supplies	
Power supply, 60 W, 56 V with Gbps support	N000065L001B
AC+DC enhanced power injector	C000065L002C

Cambium description	Cambium part number
Line cord, Fig 8 – US	N000065L003A
Line cord, Fig 8 – UK	N000065L004A
Line cord, Fig 8 – EU	N000065L005A
PoE midspan, 60 W, -48 V DC input	N000000L036A
Power supply, 30 W, 56 V – Gbps support	N000000L034A
Gigabit Ethernet capable power supply - 30 V DC, 15 W	N000900L001A
Cable, UL power supply cord set, US	N000900L007A
Cable, UL power supply cord set, EU	N000900L008A
Cable, UL power supply cord set, UK	N000900L009A
AP Optional equipment	
CMM micro (Outdoor enclosure) (450 only)	1070CKHH
CMM5 controller	C000000L500B
CMM5 power and sync injector 56 V	C000000L556B
CMM5 power supply, AC, 54 V 240 W	N000000L054B
CMM5 power supply AC, 48 V, 600 W	N000000L101A
CMM5 spare controller cable – 1m	N000000L102A
CMM5 to UGPS shielded cable (20 meter)	N000000L103A
CMM5 spare DC power connector (10 pack)	N000000L104A
CMM4/CMM5 W/Ruggedized switch and GPS	1090CKHH
CMM4/CMM5 no switch	1091HH
CMM4/CMM5 rack mount assembly	1092HH
Ethernet cable adapter for CMM4/CMM5	N000045L001A
cnPulse – sync generator with Cambium sync	C000000L066B
RJ45 gland spare – PG16 style (Quantity 10)	N000065L033A
Blanking plug pack (Quantity 10)	N000065L036A
SM Optional equipment	
Power supply, 30 W, 56 V – Gbps support	N000000L034A
Gigabit Ethernet capable power supply – 30 V DC, 15 W	N000900L001A

Cambium description	Cambium part number
Cable, UL power supply cord set, US	N000900L007A
Cable, UL power supply cord set, EU	N000900L008A
Cable, UL power supply cord set, UK	N000900L009A
53CM offset, reflector dish kit, 4PK	HK2022A
Alignment tool headset	ACATHS-01A
IP67 doors and glands for 450b High Gain, 4-pack	N000000L135A
Accessories	
Surge suppressor (30 V DC)	600SSH
Gigabit surge suppressor (56 V DC)	C000000L033A
LPU and grounding kit (1 kit per ODU)	C000065L007B
Single mode optical SFP interface per ODU	C000065L008A
Multimode kit	C000065L009A
50 Ohm braided coaxial cable - 75 meter	30010194001
50 Ohm braided coaxial cable - 500 meter	30010195001
RF connector, N, male, straight for CNT-400 cable	09010091001
Tyco/AMP, mod plug RJ45, 100 pack	WB3177
Tyco/AMP crimp tool	WB3211
RJ45 spare grounding gland - PG16 size (Quantity 10)	N000065L033
DC LPU and grounding Kit	C000000L114A
Cable assy, shielded, 4C stereo plug -3.5mm to RJ45	N000000L127A
Mounting brackets	
Tilt bracket assembly	N000045L002A
Mounting bracket (Integrated)	N000065L031A
Mounting bracket (Connectorized)	N000065L032A
Upgrade keys	
PMP 450 4 to 10 Mbps upgrade key	C000045K002A
PMP 450 4 to 20 Mbps upgrade key	C000045K003A
PMP 450 4 to uncapped upgrade key	C000045K004A

Cambium description	Cambium part number
PMP 450 10 to 20 Mbps upgrade key	C000045K005A
PMP 450 10 to uncapped MBPS upgrade key	C000045K006A
PMP 450 20 to uncapped MBPS upgrade key	C000045K007A
PMP 450 lite AP to full AP upgrade key	C000045K008A
Extended warranty	
PMP 450 Platform AP extended warranty, 1 additional year	SG00TS4009A
PMP 450 Platform AP extended warranty, 2 additional years	SG00TS4017A
PMP 450 Platform AP extended warranty, 4 additional years	SG00TS4025A
PMP 450 Platform SM extended warranty, 1 additional year	SG00TS4010A
PMP 450 Platform SM extended warranty, 2 additional years	SG00TS4018A
PMP 450 Platform SM extended warranty, 4 additional years	SG00TS4026A

450v Series ODUs, Accessories, and Upgrade keys

Table 111: 450v Series ODUs, Accessories, and Upgrade keys

Cambium description	Cambium part number
6 GHz 450v 4x4 Integrated Access Point, 90 Degree - ROW	C060045A401B
6 GHz 450v 4x4 Integrated Access Point, 90 Degree - FCC	C060045A402B
6 GHz 450v 4x4 Integrated Access Point, 90 Degree - ISED	C060045A403B
6 GHz 450v 4x4 Integrated Access Point, 90 Degree - No Encryption	C060045A405B
6 GHz 450v 2x2 BH-SM - ROW - Radio Only 4-pack, priced per unit	C060045B201B
6 GHz 450v 2x2 BH-SM - FCC - Radio Only 4-pack, priced per unit	C060045B202B
6 GHz 450v 2x2 BH-SM - ISED - Radio Only 4-pack, priced per unit	C060045B203B
6 GHz 450v 2x2 BH-SM - No Encryption - Radio Only 4-pack, priced per unit	C060045B205B
6 GHz 450v 2x2 SM - Radio Only, 4-pack, priced per unit, 250 Mbps Throughput	C060045C200B
6 GHz 450v 2x2 SM Radio Only, 4-pack, priced per unit, uncapped	C060045C201B
6 GHz 450v 2x2 BH-SM Mechanical Dish Assembly, 4-pack, priced per unit	N060045D201A
6 GHz 450v 4x4 BH-SM - ROW - Radio Only 4-pack, priced per unit	C060045B401B
6 GHz 450v 4x4 BH-SM - FCC - Radio Only 4-pack, priced per unit	C060045B402B
6 GHz 450v 4x4 BH-SM - ISED - Radio Only 4-pack, priced per unit	C060045B403B

Cambium description	Cambium part number
6 GHz 450v 4x4 BH-SM - No Encryption - Radio Only 4-pack, priced per unit	C060045B405B
6 GHz 450v 4x4 SM Radio Only, 4-pack, priced per unit	C060045C401B
6 GHz 450v 4x4 BH-SM Mechanical Dish Assembly, 4-pack, priced per unit	N060045D401A
Upgrade keys	
6 GHz 450v Upgrade to allow SM to operate as PTP	C060045K001A
6 GHz 450v 2x2 SM Throughput Upgrade License – 250 Mbps to Uncapped	C060045K201B



Note

Some models may have a part number ending in “A” instead of “B”. This indicates a previous manufacturing location and does not affect the fit, form, or function of the radio.

Chapter 3: System Planning

This chapter provides information that helps you plan a PMP/PTP 450 Platform link.

The chapter covers the following topics:

- [Typical deployment](#)
- [Site planning](#)
- [Hazardous locations](#)
- [Radio frequency planning](#)
- [Link planning](#)
- [Planning for connectorized units](#)
- [Data network planning](#)
- [Network management planning](#)
- [Security planning](#)
- [Remote AP deployment](#)

Typical deployment

This section contains diagrams that illustrate typical PMP/PTP 450 Platform site deployments.

ODU with PoE interface to PSU

The basic configuration consists of a single Ethernet interface and a copper cable used for Power over Ethernet (PoE). This cable connects the PSU to the ODU through the PSU port, as shown in [Figure 61](#), [Figure 62](#), [Figure 63](#), [Figure 64](#), and [Figure 65](#).

Figure 61: Mast or tower installation

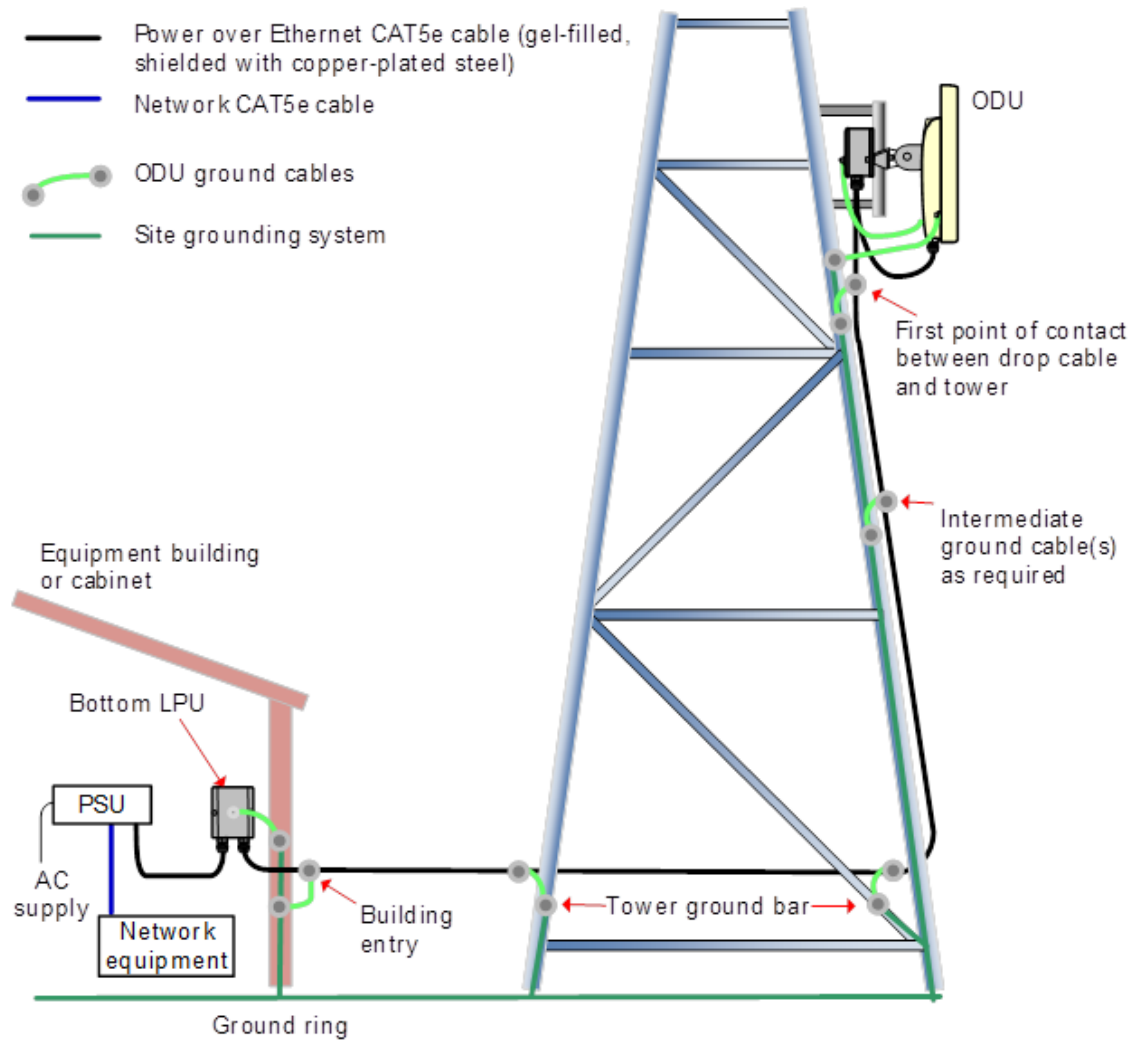

Figure 62: Wall installation

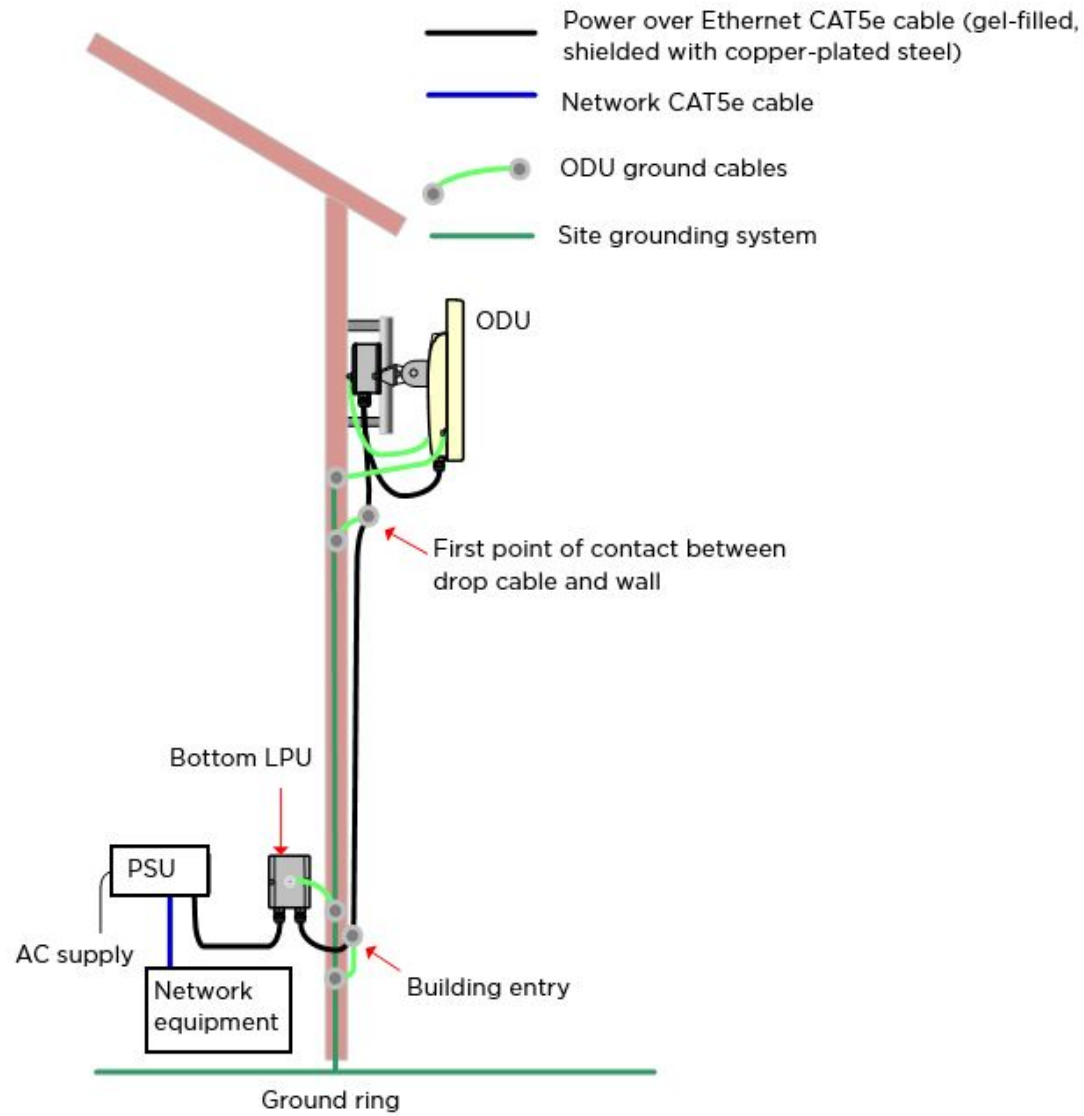

Figure 63: Roof installation

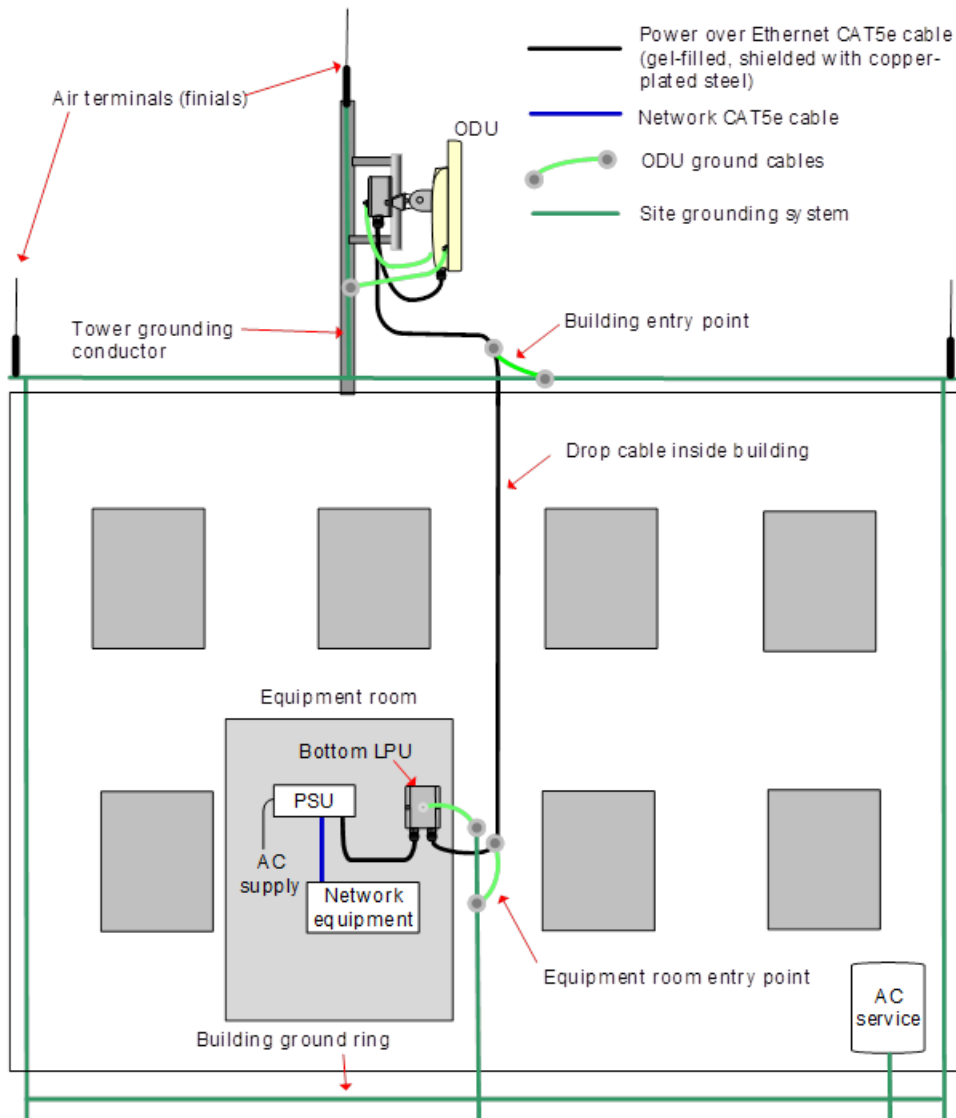

Figure 64: GPS receiver wall installation

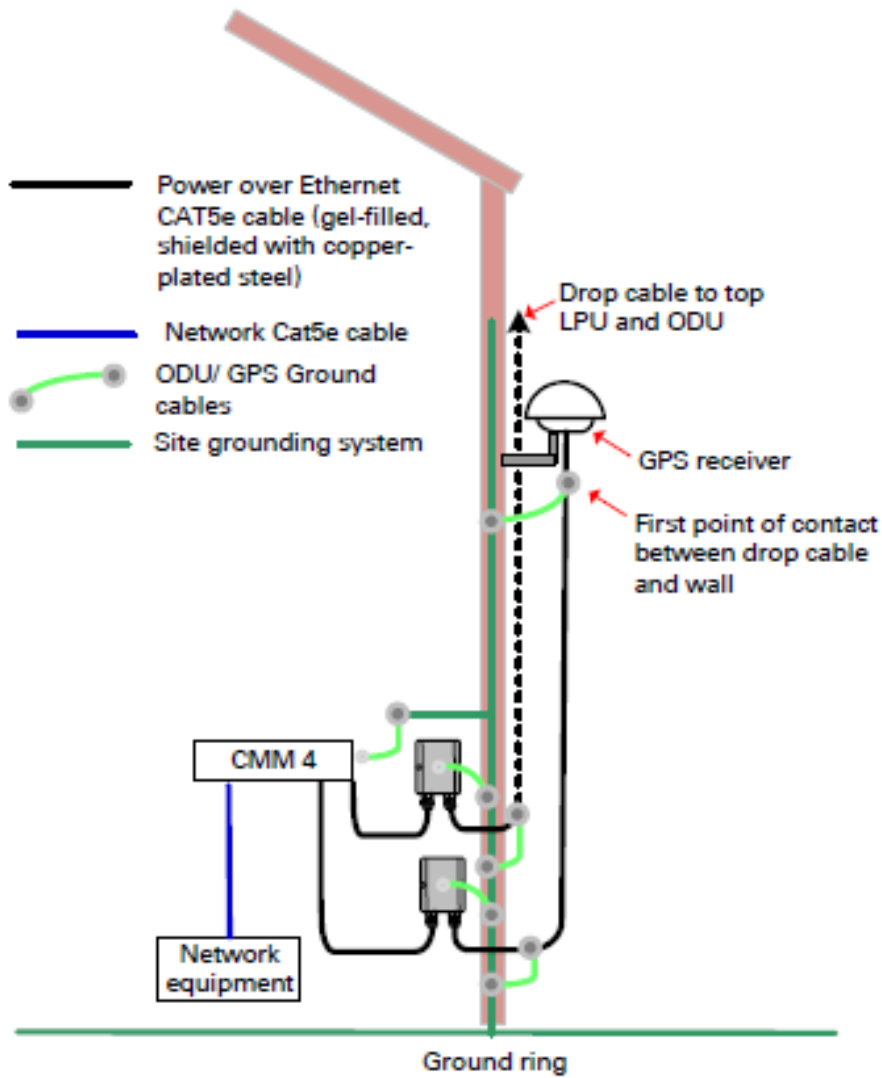
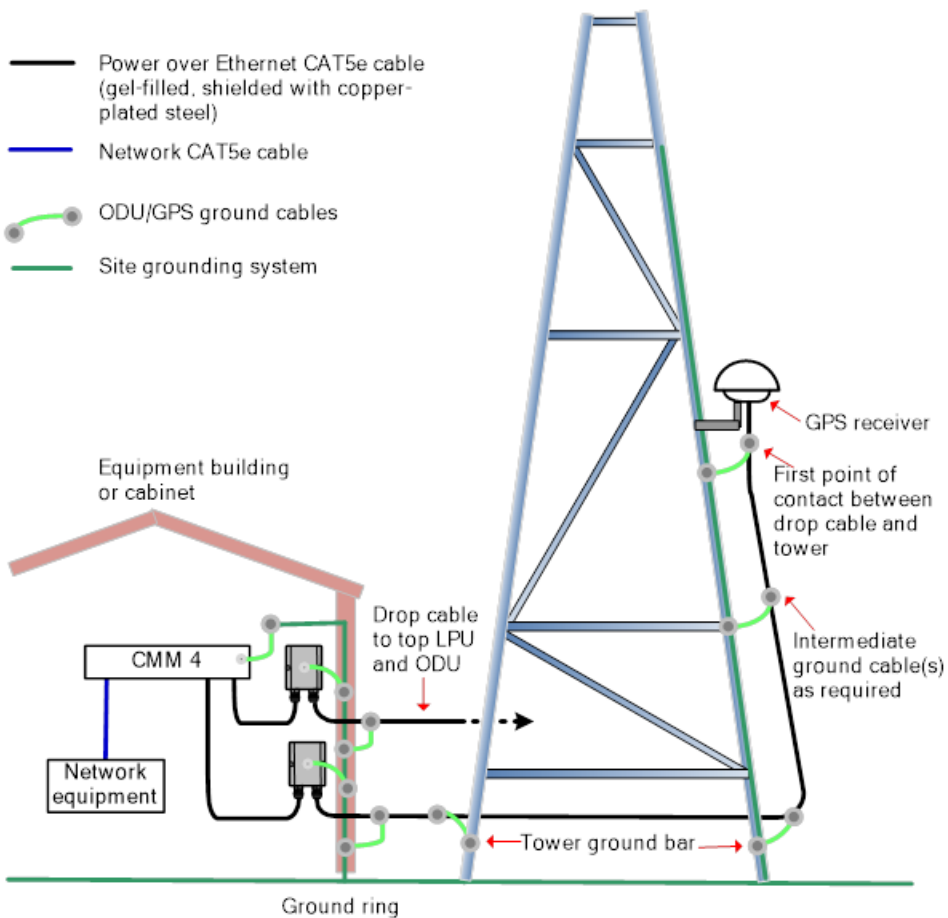

Figure 65: GPS receiver tower or mast installation



Site planning

This section describes factors to be considered when choosing sites for PMP or PTP radios, power supplies, CMM4/CMM5 and UGPS.

Site selection for PMP/PTP radios

When selecting a site for the ODU, consider the following factors:

- Height and location to achieve the best radio path.
- Indoor locations must be chosen where the power supply LED indicators are visible, ensuring that the drop cable length remains within the maximum recommended limit.
- Ability to meet the requirements specified in [Grounding and lightning protection](#).
- Aesthetics and planning permission issues.
- Cable lengths; see [Ethernet standards and cable lengths](#).

- The effect of strong winds on the installation; see [ODU wind loading](#).
- Height and location to ensure that people are kept away from the antenna.

Power supply site selection

When selecting a site for the ODU power supply, consider the following factors:

- Indoor location with no possibility of condensation, flooding or high humidity.
- Availability of a mains electricity supply.
- Located in an environment where it is not likely to exceed its operational temperature rating, allowing for natural convection cooling.
- Accessibility for viewing status indicator LED and connecting Ethernet cables.
- Cable lengths; see [Ethernet standards and cable lengths](#).

Maximum cable lengths

- When installing PMP/PTP 450i Series ODU, the maximum permitted length of the shielded copper Ethernet interface cable is 330 feet (100m) from AP/BHM/SM/BHS to their associated power supplies or CMM4/CMM5.
- When installing PMP 450m Series ODU, the maximum permitted length of the shielded copper Ethernet interface cable is 330 feet (100m) from ODU to the network interface equipment.
- The 3 GHz PMP 450M ODU can use a 1.0 mm 984.25 feet (300m) power cable.

Grounding and lightning protection



Warning

While electro-magnetic discharge (lightning) damage is not covered under warranty, following the recommendations in this guide correctly provides users with the best possible protection against the harmful effects of EMD. It's essential to note that achieving 100% protection is neither implied nor attainable.

To safeguard structures, equipment, and individuals from power surges, often resulting from lightning strikes, it is crucial to establish a dedicated and robust path for directing surge currents safely to the ground. The extent of protection required varies based on local conditions and relevant regulations. For comprehensive protection of a PMP/PTP 450 Platform installation, both ground bonding and transient voltage surge suppression measures are essential.

Comprehensive guidance on lightning protection methods and requirements can be found in internationally recognized standards such as IEC 61024-1 and IEC 61312-1, as well as in national codes like the U.S. National Electric Code ANSI/NFPA No. 70-1984 and section 54 of the Canadian Electric Code.



Warning

Never mount equipment in Zone A. Doing so poses a significant risk to equipment, structures, and lives.

Lightning protection zones

Determining lightning protection zones is achieved using the Rolling Sphere Method. In this approach, we roll an imaginary sphere, typically with a 50-meter radius, across the structure. When the sphere touches the ground and a strike termination device like a finial or ground bar, all the space beneath the sphere is designated as Zone B, indicating it falls within the protection zone. Likewise, if the sphere rests on two finials, the area underneath is also considered part of the protection zone.

Figure 66: Rolling sphere method to determine the lightning protection zones

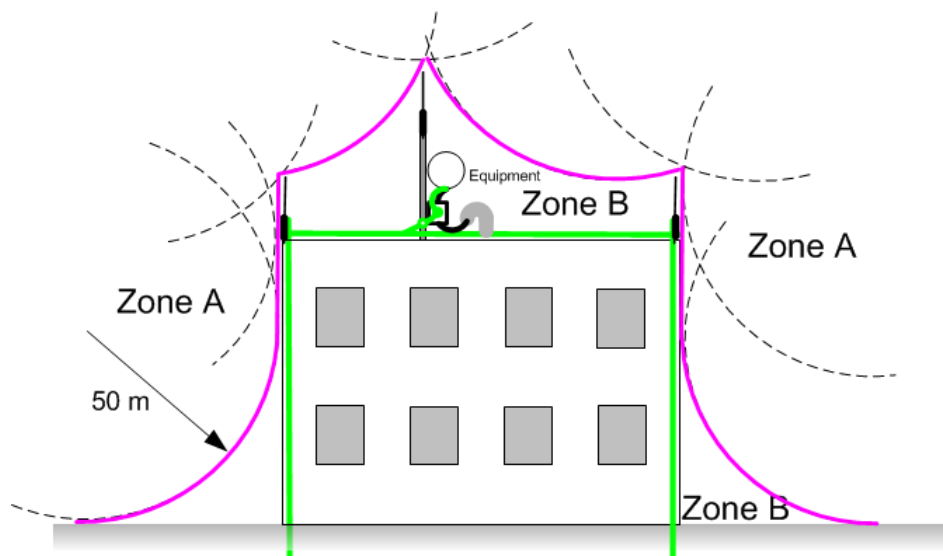

Zone A: In this zone, a direct lightning strike is possible. Do not install equipment in this zone.

Zone B: In this zone, while direct electromagnetic discharge (lightning) effects are still possible, installing equipment significantly reduces the likelihood of a direct strike. You can safely install equipment in this zone.

Site grounding system

Confirm that the site has a correctly installed grounding system on a common ground ring with APs for grounding the 450 Platform Family ODU.

If the outdoor equipment is to be installed on the roof of a high building (Roof installation), confirm that the following additional requirements are met:

- A grounding conductor is installed around the roof perimeter to form the main roof perimeter lightning protection ring.

- Air terminals are installed along the length of the main roof perimeter lightning protection ring, typically every 6.1m (20ft).
- The main roof perimeter lightning protection ring contains at least two down conductors connected to the grounding electrode system. The down conductors must be physically separated from one another, as far as practical.

ODU and external antenna location

Select a location for the ODU (and external antenna for connectorized units) that satisfies the following criteria:

1. Optimal Elevation for Radio Path:
 - Ensure sufficient elevation to optimize the radio path.
2. Compliance with Safety Distances:
 - Maintain adherence to calculated safe separation distances for personnel.
3. Lightning Protection and Structure Height:
 - Position the equipment below the top of the supporting structure (e.g., tower, mast, or building) or its lightning air terminal.
4. Connectorized ODU Considerations:
 - When dealing with a connectorized ODU, choose a mounting position that maximizes protection against environmental elements while allowing straightforward access for cable connections and weatherproofing.
 - Minimize antenna cable lengths to reduce signal losses.
 - Note that when deploying diverse or dual external antennas, there is no requirement to mount the ODU at the midpoint of the antennas.

ODU ambient temperature limits

Select a location where the ODU can operate within specified ambient temperature limits, taking into account the following considerations:

1. Restricted Access Location (per EN 60950-1):
 - If the operating ambient temperature, including solar radiation, may exceed 40°C, mount the ODU in a Restricted Access Location as defined in EN 60950-1.

2. Temperature Limits for External Metal Case Parts:

- If the ambient temperature remains below 40°C, the temperature of the external metal case parts of the ODU does not exceed the touch temperature limit of 70°C.
- If the ambient temperature remains below 60°C, the temperature of the external metal case parts of the ODU does not exceed the touch temperature limit of 90°C.



Note

A restricted access location is defined (in EN 60950-1) as one where access may only be gained by use of a tool or lock and key, or other means of security, and access is controlled by the authority responsible for the location. Access must only be gained by persons who have been instructed about the reasons for the restrictions applied to the location and about any precautions that must be taken. Examples of permissible restricted access locations are a lockable equipment room or a lockable cabinet.

ODU wind loading

Ensure that the ODU and the mounting structure can withstand the prevailing wind speeds at the proposed 450 Platform site. Wind speed data can be obtained from national meteorological offices.

The ODU and its mounting bracket are rated for the following wind speeds:

- Up to 200 mph (322 kph) for PMP 450m Series – AP 5 GHz
- Up to 124 mph (200 kph) for PMP 450m Series – AP 3 GHz
- Up to 124 mph (Integrated) for PMP/PTP 450i – all models 3 GHz and 5 GHz
- Up to 200 mph (Connectorized) for PMP/PTP 450i – all models 3 GHz and 5 GHz
- Up to 200 mph (322 kph) for PMP/PTP 450 – all models
- Up to 200 mph (322 kph) for PMP 450 – Ruggedized
- Up to 200 mph (322 kph) for PMP 450i – all models 900 MHz
- Up to 118 mph (191 kph) for PMP 450b Mid-Gain
- Up to 90 mph (145 kph) for PMP 450b High Gain
- Up to 90 mph (145 kph) for PMP 450d
- Up to 100 mph (161 kph) for 900 MHz antennas
- Up to 124 mph (200 kph) for PMP 450 MicroPoP Series - AP 5 GHz

- Up to 124 mph (200 kph) for PMP/PTP 450b Retro Series - 5 GHz
- Up to 124 mph (200 kph) for 450v series

Wind blowing on the ODU subjects the mounting structure to significant lateral force, with the force magnitude depending on both wind strength and the surface area of the ODU. Wind loading is estimated using the following formulas:

- Force (in kilograms) = $0.1045aV^2$
where:
 - **a** is the surface area in square meters, and **V** is the wind speed in meters per second
- Force (in pounds) = $0.0042Av^2$
- where:
 - **A** is the surface area in square feet, and
 - **v** is the wind speed in miles per hour

By applying these formulas to the 450 Platform at various wind speeds, the resulting wind loadings are presented in the tables below.

Table 112: PMP 450m Series wind loading (Newton)

Type of ODU	Max surface area (square feet)	Wind speed (kilometer per hour)				
		160	170	180	190	200
Integrated 90° sector antenna	0.331	671	757	849	946	1048

Table 113: PMP/PTP 450i Series wind loading (Newton)

Type of ODU	Max surface area (square meters)	Wind speed (kilometer per hour)				
		160	170	180	190	200
Connectorized	0.035	94	106	119	132	146
Directional Yagi antenna - 900 MHz	0.025	67	76	85	94	105
External 65° sector antenna – 900 MHz	0.253	677	764	857	954	1058
Directional antenna – 3.x GHz	0.1	142	160	180	200	222
Integrated 90° sector antenna -3.x GHz	0.18	83	94	105	117	130
Directional antenna – 5 GHz	0.093	249	281	315	351	389
Integrated 90° sector antenna - 5 GHz	0.126	337	381	427	475	527

Table 114: PMP 450m Series wind loading (lb force)

Type of ODU	Max surface area (square feet)	Wind speed (miles per hour)				
		100	105	110	115	120
Integrated 90° sector antenna	3.565	150	165	181	198	216

Table 115: PMP/PTP 450i Series wind loading (lb force)

Type of ODU	Max surface area (square feet)	Wind speed (miles per hour)				
		100	105	110	115	120
Connectorized	0.377	16	17	19	21	23
Directional antenna – 5 GHz	1.001	42	46	51	56	61
Integrated 90° sector antenna - 5 GHz	1.356	57	63	69	75	82
Directional Yagi antenna - 900 MHz	0.27	11	13	14	15	16
External 65° sector antenna – 900 MHz	2.72	114	126	138	151	165

For a connectorized ODU, add the wind loading of the external antenna to that of the ODU. The antenna manufacturer must be able to quote wind loading.

Table 116: PMP/PTP 450 Series wind loading (Newton)

Type of ODU	Max surface area (square meters)	Wind speed (kilometer per hour)				
		160	170	180	190	200
External 60° sector antenna – 2.4 GHz AP	0.27	722	815	914	1019	1129
External 60° sector antenna – 5 GHz AP	0.066	177	199	223	249	276
External 90° sector antenna – 5 GHz AP	0.083	222	251	281	313	347
SM	0.027	72	82	91	102	113
Integrated High Gain, Ruggedized	0.093	249	281	315	351	389
Integrated Dish	0.14	375	423	474	528	585

Table 117: PMP/PTP 450 Series wind loading (lb force)

Type of ODU	Max surface area (square feet)	Wind speed (miles per hour)				
		100	105	110	115	120
External 60° sector antenna – 2.4 GHz AP	2.9	122	134	147	161	175
External 60° sector antenna – 5 GHz AP	0.71	29.8	33	37	39	43
External 90° sector antenna – 5 GHz AP	0.89	37	41	45	49	54
SM	0.29	12	13	15	16	18
Integrated High Gain, Ruggedized	1	42	46	51	56	60
Integrated Dish	1.49	63	69	76	83	90

Table 118: PMP 450b Series wind loading (Newton)

Type of ODU	Max surface area (square meters)	Wind speed (miles per hour)				
		160	170	180	190	200
Integrated Mid-Gain	0.03	80	90	101	113	125
Integrated High Gain	0.13	347	392	440	490	543

Table 119: PMP 450b Series wind loading (lb force)

Type of ODU	Max surface area (square feet)	Wind speed (miles per hour)				
		100	105	110	115	120
Integrated Mid-Gain	0.33	13	15	16	18	19
Integrated High Gain	1.41	59	65	71	78	85

Hazardous locations

Confirm that the ODUs are not exposed to hazardous gases, as defined by HAZLOC (USA) and ATEX (Europe) regulations. In case of potential exposure, order the PTP/PMP 450i ATEX/Hazloc product variants, designed for operation in gas hazard environments. The ATEX and HAZLOC standards impose limits on the EIRP, detailed in EIRP limits from ATEX and HAZLOC standards.

Table 120: EIRP limits from ATEX and HAZLOC standards

ATEX gas group	HAZLOC gas group	Typical gas type	Maximum EIRP (Watt)
IIA	D	Propane	6
IIB	C	Ethylene	3.5
IIC	B	Hydrogen	2
IIC	A	Acetylene	2

Drop cable grounding points

To determine the number of grounding kits needed for each drop cable, refer to the site installation diagrams (Mast or tower installation, Wall installation, and Roof installation), and apply the following criteria:

- Ground the drop cable shield at the first point of contact between the drop cable and the mast, tower, or building, near the ODU.
- Ground the drop cable shield at the building entry point.

For Mast or Tower Installations (Mast or tower installation), include the following additional criteria:

- Ground the drop cable shield at the bottom of the tower, near the vertical to horizontal transition point. Bond this ground cable to the tower or tower ground bus bar (TGB), if present.
- If the tower exceeds 61 meters (200 feet) in height, ground the drop cable shield at the tower midpoint and at additional points as necessary to maintain distances between ground cables at 61 meters (200 feet) or less.
- In regions prone to frequent lightning strikes, ground the drop cable shield at intervals ranging from 15 to 22 meters (50 to 75 feet), particularly on towers exceeding 45 meters (150 feet) in height.

For Roof Installations (Roof installation), follow these additional criteria:

- Bond the drop cable shield to the building grounding system at its upper entry point (typically on the roof).
- Bond the drop cable shield to the building grounding system at the entry point to the equipment room.

Lightning Protection Unit (LPU) location

Select a location for the bottom LPU that fulfills the following criteria:

- Ensure that the bottom LPU can be connected to the drop cable from the ODU.
- Position the bottom LPU within 600 mm (24 inches) of the point where the drop cable enters the building, enclosure, or equipment room within a larger building.
- Ensure that the bottom LPU can be effectively bonded to the grounding system.

Radio Frequency planning

This section outlines how to plan 450 Platform Family links to align with spectrum analysis and the regulatory restrictions applicable in the country of operation.

Regulatory limits

- Many countries impose EIRP limits (Allowed EIRP) on products operating in the bands used by the 450 Platform Family.
 - Refer to the **Country Specific Radio Regulations** section of the *PMP 450 Series Configuration Guide* to determine the maximum transmitted power and EIRP for PMP/PTP 450 Platform that can be used in each of the countries and frequency bands.



Caution

The user is responsible for ensuring that the PMP/PTP ODU is operated in compliance with local regulatory limits.



Note

Contact the relevant radio regulator to determine if registration of the PMP/PTP 450 Platform link is necessary.

Available spectrum

The available spectrum for operation depends on the regulatory band. When configured correctly, the unit restricts operation to channels permitted by the regulations. Some regulations have designated specific

channels as unavailable for use:

- FCC has allocated a portion of the 5.1 & 5.2 GHz bands.
- ETSI has allocated a section of the 5.4 GHz band to weather radar.
- The UK and some other European countries have allocated a portion of the 5.8 GHz band to Road Transport and Traffic Telematics (RTTT) systems.

The number and identity of restricted channels within a given regulatory band depend on the channel bandwidth and channel raster selected.

Analyzing the RF Environment

An indispensable component of RF network planning involves the assessment of spectrum utilization and the strength of signals occupying the spectrum. Irrespective of the methods used for measurement and recording of results (utilizing the Spectrum Analyzer feature or employing a spectrum analyzer), it is crucial to ensure that measurements are conducted:

- At various times of the day
- On different days of the week
- Periodically in the future

This approach helps to keep users informed about the dynamic potential for interference within the network, especially as new RF neighbors enter or as consumer devices proliferate in currently used spectrum.

Channel bandwidth selection

Choose the necessary channel bandwidth for the link, contingent upon the selected regulatory band.

- A wider channel bandwidth results in greater capacity.
- In locations with high spectrum congestion, opting for a narrower channel bandwidth is often a more suitable choice as it occupies less spectrum.

It is essential to configure both ends of the link to operate on the same channel bandwidth.

Anticipating reflection of radio waves

In the signal path, any object larger than the wavelength of the signal can reflect the signal. This can include surfaces such as the earth, rivers, bays, or lakes. The wavelength of the signal varies, approximately:

- 2 inches (or 5 cm) for 5.4 GHz and 5.8 GHz signals.
- 12 inches for 900 MHz signals.

A reflected signal may arrive at the receiver's antenna later than the non-reflected signal, resulting in multipath conditions. Multipath can either increase or decrease the signal level, leading to overall

attenuation that may differ from that caused solely by the link distance. This phenomenon is particularly critical at the margin of the link budget, where the standard operating margin (fade margin) may be compromised.

Obstructions in the Fresnel zone

The Fresnel (pronounced fre-NEL) Zone constitutes a three-dimensional volume surrounding the line of sight of an antenna transmission. Objects that intrude into this region can lead to signal fading in the received strength of the transmitted signal. Signal cancellation occurs due to out-of-phase reflections and signal absorption.

Foliage from trees and plants within the Fresnel Zone can contribute to signal loss. The degree of loss may vary based on seasonal foliage density, moisture content, and other factors such as wind. If it's necessary to transmit through foliage, consider conducting frequent and regular link tests to assess and mitigate the impact.

Planning for co-location

Co-location between OFDM (450 Series) and FSK (PMP/PTP 1x0)

To prevent interference in wireless systems, follow these steps:

1. Set all AP/BHMs to receive timing from a synchronization source, such as the Cluster Management Module or Universal Global Positioning System. This synchronization ensures that the modules are aligned and commence transmission simultaneously in each frame.
2. Configure parameters on all AP/BHMs within the same frequency band and proximity to have compatible transmit/receive ratios. Ensure that all modules stop transmitting before any start receiving. This arrangement prevents situations where one AP/BHM attempts to receive a signal from a distant SM/BHS while a nearby AP/BHM is transmitting, potentially overpowering the received signal.



Note

Refer to Frame Alignment Legacy Mode parameter of **Configuration > Radio > Advance** tab for legacy product settings.

Determining transmit/receive ratio parameters:

The following parameters on the AP/BHM are responsible for determining the transmit/receive ratio:

- Downlink Data percentage
- Frame Period
- Max Range
- (Reserved) Contention slots

When OFDM (450 Platform Family) and FSK (PMP/PTP 1x0) APs/BHMs sharing the same frequency band and channel bandwidth are in close proximity or when you wish to configure BHMs with different parameters, the Frame Calculator becomes invaluable. It helps identify compatible settings for APs/BHMs.

Co-location is also supported for 900 MHz PMP 450i Series APs (OFDM) and PMP 100 Series APs (FSK).

You can access the Frame Calculator through the web management interface at Tools > Frame Calculator. To utilize the Frame Calculator, input various configurable parameter values for each nearby AP/BHM and note the resulting AP/BHM Receive Start value. Then, adjust the Downlink Data percentage in each calculation and iterate until you obtain a calculated AP/BHM Receive Start value where the transmit end does not precede the receive start.

Cambium also provides co-location tool which helps in co-location planning:

<https://support.cambiumnetworks.com/files/colocationtool>

For more information on 450 Platform Family co-location, see <http://www.cambiumnetworks.com/solution-papers>

For Cambium co-location tool refer section **Cambium co-location tool** in *Configuration Guide*.

Co-location between Cambium 3 GHz PMP devices and LTE and 5G-NR devices

When co-locating deployments in the same geographical area it is important to select the correct system parameters in order to avoid interference.

Cambium PMP, LTE, and 5G-NR are all TDD systems, which means that the same frequency resources are used both in the downlink and in the uplink but multiplexed in time. A TDD cycle, or frame, is the minimum amount of time used to communicate in both directions, including gaps for hardware turnaround and over-the-air propagation delays.

When multiple APs are deployed in the same geographical area, they all must transmit and receive at the same time. If one AP transmits when another receives, the AP that is receiving might not be able to correctly decode the signal coming from the SMs communicating with it, because of the interfering signal coming from the other AP.

To avoid such interference, consider these three aspects:

1. The TDD cycle, or frame, needs to have the same length for all APs
2. The TDD cycle, or frame, needs to start at the same time for all APs
3. The frame parameters need to be selected in each AP so that there is no overlap between one AP transmitting and another receiving. An example of these parameters is the duty cycle, i.e. the ratio of the time dedicated to communication in the downlink direction over the total time frame.



Note

The above parameters do not need to be the same in all APs, but they need to be selected to avoid interference. These features are needed regardless of the technology used by the APs.

Co-location with LTE

LTE frame configuration options

Table 121 summarizes the LTE frame configuration options.

LTE supports two frame lengths, 5 ms and 10 ms. Each 10 ms interval contains 10 subframes, which are labeled in the Table 121 as **D** for downlink transmission, **U** for uplink transmission, and **S** for special subframe. The special subframe contains the turnaround time between downlink and uplink transmissions.

In Table 121, each subframe corresponds to 1 ms.

Configuration options with a 10 ms frame time have one **S** frame only, as they switch from transmit to receive only one time within the 10 ms.

Configuration options with a 5 ms frame time have two **S** frames, as they switch twice from transmit to receive within the 10 ms. Configurations 0, 1, and 2 have the same D/U/S subframes in the first 5 ms and the second 5 ms of the 10 ms period. Essentially, the 5 ms structure is repeated.

Configuration 6 is the only one with two S frames where the two 5 ms portions are not identical.

Table 121: LTE frame configuration options

Configuration	Frame time	Subframe number									
		0	1	2	3	4	5	6	7	8	9
0	5 ms	D	S	U	U	U	D	S	U	U	U
1	5 ms	D	S	U	U	D	D	S	U	U	D
2	5 ms	D	S	U	D	D	D	S	U	D	D
3	10 ms	D	S	U	U	U	D	D	D	D	D
4	10 ms	D	S	U	U	D	D	D	D	D	D
5	10 ms	D	S	U	D	D	D	D	D	D	D
6	5 ms	D	S	U	U	U	D	S	U	U	D

Frame length

TDD systems can be co-located only if they have the same frame length.

Figure 67 shows why it is not possible to co-locate APs supporting mismatched frame lengths.

Let us assume that AP1 operates with a 10 ms frame while AP2 operates with a 5 ms frame. Figure 67 shows that in a 10 ms interval, AP1 has one transmit time and one receive time, while AP2 has two transmit times and two receive times.

The interference that most affects the system performance is the one at the AP receiver.

For example, in the time indicated with the green arrow in Figure 67, AP1 transmits when AP2 receives. This may completely corrupt the reception of AP2's uplink signal.

Also, in the time indicated with the orange arrow in [Figure 67](#), AP2 transmits when AP1 receives. This may completely corrupt the reception of AP1's uplink signal.

Figure 67: Mismatched frame length

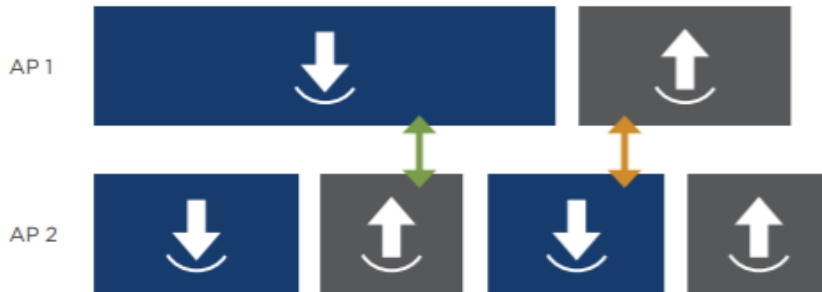

As indicated above, LTE supports 5 ms and 10 ms frame lengths. Cambium PMP devices support 2.5 ms and 5 ms frame length. The only option for co-locating LTE and Cambium PMP devices is for both systems to operate with a 5 ms frame. This means that a Cambium PMP system can be co-located with an LTE system operating with Frame Configurations 0, 1 or 2.

Ensure that frame configuration 6 also turns around twice in the 10 ms interval, and its frame length is 5 ms. However, the two 5 ms frames in the 10 ms interval are not identical.

Since in the Cambium PMP system all frames have the same downlink/uplink structure, the Cambium PMP system cannot be co-located with an LTE system operating with Frame Configuration 6.

In the Cambium PMP UI the frame length is selected in the **Configuration > Radio > Radio Configuration** page under Frame Period, as shown in [Chapter 3](#).

This parameter must be configured to 5 ms.

Figure 68: Frame length selection in Cambium PMP GUI

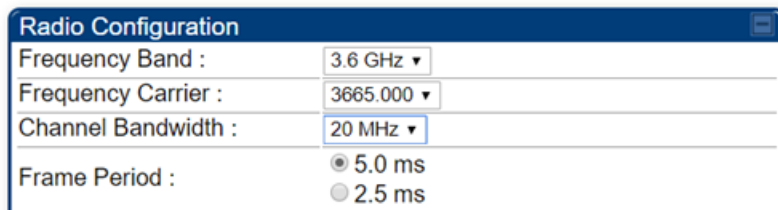

Frame start

GPS synchronization is a way of guaranteeing that the frame start is the same for all APs. This is what is used by the Cambium PMP devices.

However, the timing between the GPS signal and the start of the TDD frame is not necessarily the same for all systems. The Cambium PMP devices and the LTE devices have different start times for their frames, and additionally, LTE has different frame start times for each frame configuration.

The Cambium PMP Radio configuration page offers an LTE co-location option in the GUI Radio page, that allows the user to co-locate Cambium PMP devices with LTE devices by shifting the start of the PMP frame to match the start of the selected LTE frame.

This can be found under **Configuration > Radio > Frame Configuration**, as shown in [Figure 69](#).

Figure 69: Options for co-location with LTE systems

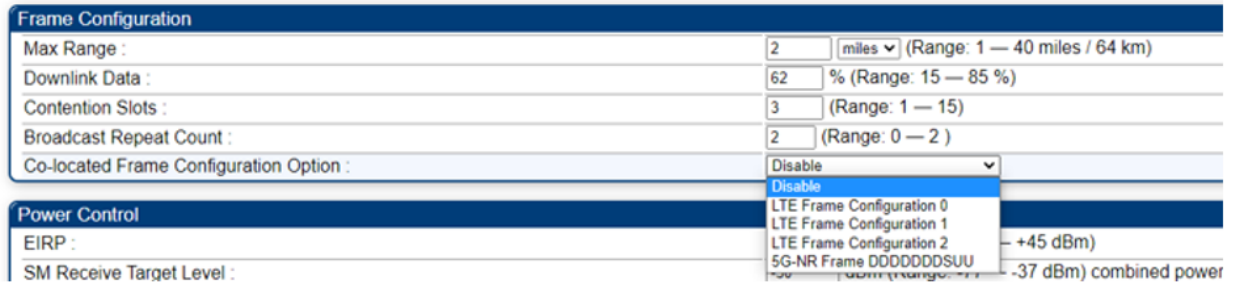

If the Co-located Frame Configuration Option is selected as Disable, then the Cambium PMP frame start is not shifted from its default timing.

If any of the three LTE options (LTE Frame Configuration 0, 1, or 2) is selected, the Cambium PMP frame start is shifted to align with the LTE frame start for the selected frame configuration.

The Cambium PMP frame always starts with the downlink portion of the frame, followed by the turnaround time and then the uplink portion of the frame.

The LTE 10-ms interval, however, always starts with subframes D, S, and U as the first three subframes, but it may have additional downlink subframes in the same frame.

For example, in Frame Configuration 1 the 10 ms interval is composed of two repetitions of the following subframes: D, S, U, U, D. To align the Cambium PMP frame to this LTE frame, the downlink start has to align to the beginning of subframe 4, not subframe 0. With this shift, the sequence of subframes in the LTE frame becomes D, D, S, U, U, which is the same structure as the Cambium PMP frame (downlink, turnaround time, uplink).

When selecting one of the LTE Frame Configuration options from the Co-located Frame Configuration Option drop-down menu, a shift is applied to the Cambium PMP frame to correctly line up with the selected LTE frame.

When enabling co-location with LTE, as well as any time a different LTE Frame configuration is selected, the AP needs to be rebooted.

Frame parameters

After following the steps described above, the Cambium PMP and the LTE APs are synchronized, and their frame length is the same. Next, the frame parameters have to be selected to avoid any overlap between one AP transmitting and another receiving.

Figure 70 and Figure 71 provide examples of frames that illustrate the distinction between non-interfering and interfering scenarios. In both Figures, the downlink time and the uplink time of the two APs are not identical.

In Figure 70 there is no overlap between one AP transmitting and the other AP receiving, and the two APs can be co-located.

In Figure 71 however, AP1 is still transmitting when AP2 is already receiving. This creates interference at the AP2's receiver and the APs cannot be co-located with these parameters.

Figure 70: Example of APs that can be co-located



Figure 71: Example of APs that cannot be co-located

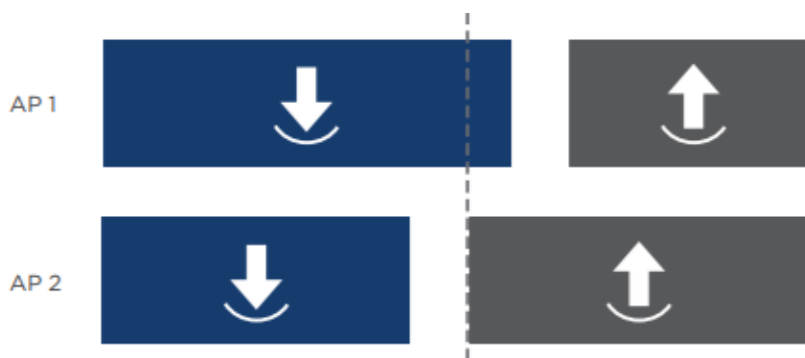

Once the LTE Frame Configuration is selected from the drop-down menu, the LTE downlink and uplink times are defined.

The Cambium PMP frame times are determined by the following configuration parameters:

- **Channel bandwidth:** This parameter defines the amount of spectrum allocated for communication in the sector. In the 3 GHz band, you have various options for Channel bandwidth, including 5 MHz, 7 MHz, 10 MHz, 15 MHz, 20 MHz, 30 MHz, and 40 MHz.
- **Maximum range:** Maximum range represents the distance between the AP and the farthest SM communicating with the AP. Maximum range can be selected in miles, ranging from 1 to 40.
- **Downlink data:** This parameter indicates the duty cycle, which is the ratio between the time dedicated to downlink transmission and the total frame time. Downlink data is selected as a percentage, with options between 15% and 85%.
- **Contention slots:** Contention slots represent time symbols reserved in the uplink portion of the frame for random access, registration, and bandwidth request purposes. Contention slots can be set as a number between 1 and 15.

The Channel bandwidth can be configured under **Configuration > Radio > Radio Configuration**, as shown in [Figure 72](#).

Figure 72: Channel bandwidth configuration

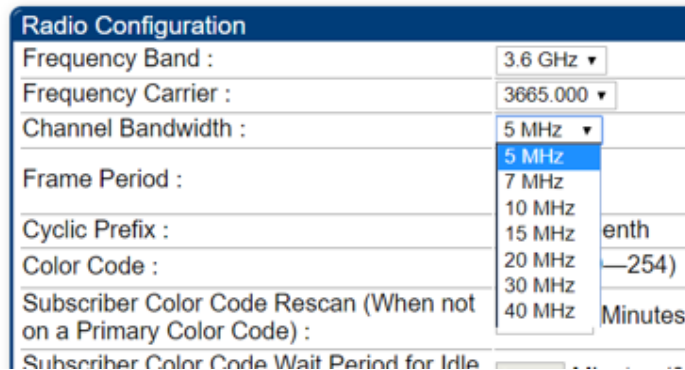

All other parameters can be configured under **Configuration > Radio > Frame Configuration**, as shown in Figure 73.

Figure 73: Cambium PMP frame configuration parameters

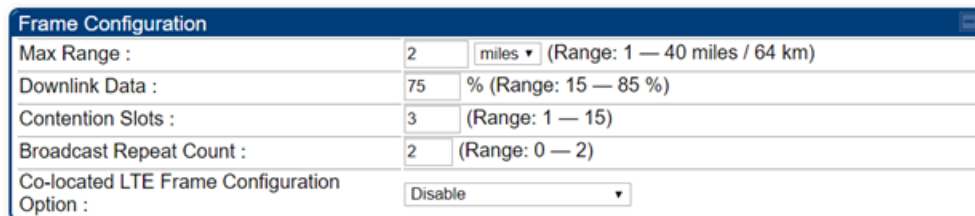

PMP–LTE co-location tool

Prior to Release 22.0, the user had to use the PMP-LTE co-location tool provided by Cambium to correctly select the configuration parameters for co-location with LTE.

Starting with Release 22.0, the radio automatically adjusts the duty cycle to allow co-location, but the co-location tool is described here because it can still be used as a reference ahead of time, to know what to expect in terms of the radio's calculations of the duty cycle.

The PMP – LTE co-location tool is available here: <https://support.cambiumnetworks.com/files/colocationtool/>

The PMP and LTE configuration parameters are entered in the spreadsheet, and the frame structure for the two systems is displayed on the right side.

The tool checks that there is no overlap between one AP transmitting and the other receiving.

This translates into two equations:

- The downlink time of AP1 ends before the uplink time of AP2 starts
- The downlink time of AP2 ends before the uplink time of AP1 starts

In the example in Figure 74, the second equation is not satisfied, and the two systems cannot be co-located. The plot to the right also shows that with this frame configuration the LTE AP is still transmitting when the PMP AP is already receiving. This creates interference at the PMP AP receiver.

Figure 74: Example of PMP - LTE co-location with invalid parameters

PMP - LTE co-location tool					
PMP Configuration		LTE Configuration			
Mode	PMP	Frame Configuration	2		
Channel Bandwidth (MHz)	20	S frame configuration	7		
Max Range (mi)	5	DL Cyclic Prefix	Normal		
		UL Cyclic Prefix	Normal		
Dowlink Data		70%			
Contention slots		3			
Frame Period (ms)		5			
PMP Timing (ms)		LTE Timing (ms)			
DL end	3.271	DL end	3.715		
UL start	3.457	UL start	3.857		
CHECKS					
PMP DL end	3.271	<	LTE UL start	3.857	OK
LTE DL end	3.715	<	PMP UL start	3.457	OK

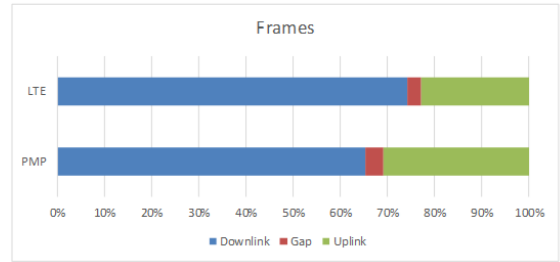

Using the tool, parameters can be updated in order to find a set of values that allows for co-location. For example, changing the duty cycle of the PMP AP from 70% to 80% makes both equations true, and there is no longer overlap between one AP transmitting and the other receiving.

Figure 75: Example of PMP - LTE co-location with valid parameters

PMP - LTE co-location tool					
PMP Configuration		LTE Configuration			
Mode	PMP	Frame Configuration	2		
Channel Bandwidth (MHz)	20	S frame configuration	7		
Max Range (mi)	5	DL Cyclic Prefix	Normal		
		UL Cyclic Prefix	Normal		
Dowlink Data		80%			
Contention slots		3			
Frame Period (ms)		5			
PMP Timing (ms)		LTE Timing (ms)			
DL end	3.708	DL end	3.715		
UL start	3.894	UL start	3.857		
CHECKS					
PMP DL end	3.708	<	LTE UL start	3.857	OK
LTE DL end	3.715	<	PMP UL start	3.894	OK

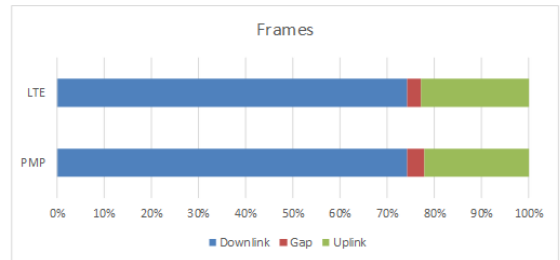

Automatic duty cycle adjustment

Starting in Release 22.0, the user no longer needs to use the PMP-LTE co-location tool. The AP now automatically adjusts the allowed range of Downlink Data percentage (duty cycle) on the AP's **Configuration > Radio** page to ensure no overlap with the LTE system occurs.

Figure 76: Example of co-location Downlink Data range and additional LTE parameters

Frame Configuration	
Max Range :	5 miles (Range: 1 — 120 miles / 193 km)
Downlink Data :	35 % (Range: 32 — 37 %)
Contention Slots :	3 (Range: 0 — 15)
Broadcast Repeat Count :	2 (Range: 0 — 7)
Co-located Frame Configuration Option :	LTE Frame Configuration 0
Co-located LTE S Frame Configuration :	7
Co-located LTE Cyclic Prefix :	Normal

Figure 76 shows an example of the Downlink Data range being automatically adjusted to 32%-37% after selecting the co-location with the LTE Frame Configuration 0 option. The user is only allowed to enter a value within this updated range.

To use this new improvement, the user also needs to specify the LTE subframe configuration in use as well as whether a normal or extended cyclic prefix is used. These additional parameters are also shown in Figure 76.

For any existing PMP sector already running LTE co-location, when upgrading to Release 22.0, if the current configuration introduces an overlap with LTE, the Downlink Data percentage is automatically adjusted for the operator to the nearest allowed value.

Ensure that when upgrading to Release 22.0 with LTE co-location already enabled, the two new configuration parameters default to the following values:

- Co-located LTE S Frame Configuration: 7
- Co-located LTE Cyclic Prefix: Normal

If the user needs to configure different values for these parameters, they can either change them in the AP GUI after the upgrade, or they can send a template from cnMaestro to all the APs that need to be updated with the same parameters.

The template to use is available on the Cambium support page:

<https://support.cambiumnetworks.com/files/pmp450/>.

If the sector is upgraded with the LTE co-location feature turned off, and then in Release 22.0 the feature is turned on, the two parameters above default to the following values:

- Co-located LTE S Frame Configuration: 0
- Co-located LTE Cyclic Prefix: Normal

Again, if the user wants to select different values, they can change them in the AP GUI or send a template to all the APs that need to be updated with the same parameters.

Co-location with 5G-NR

Release 22.0 also introduces the option to co-locate with 5G-NR devices.

5G-NR frame configuration options

The 5G-NR standard offers a lot of flexibility in terms of frame structure options. The PMP system will first allow co-location with some of these options, and more can be added over time as needed.

Currently, co-location with these 5G-NR frame options is supported:

- DDDSU
 - Frame length: 2.5 ms
 - Number of full DL slots: 3

- Number of full UL slots: 1
- Special subframe: 10 DL symbols + 2 guard symbols + 2 UL symbols
- DDDDDDSUU – 4 guard symbols
 - Frame length: 5 ms
 - Number of full DL slots: 7
 - Number of full UL slots: 2
 - Special subframe: 6 DL symbols + 4 guard symbols + 4 UL symbols DDDSU
- DDDDDDSUU (6 guard symbols)
 - Frame length: 5 ms
 - Number of full DL slots: 7
 - Number of full UL slots: 2
 - Special subframe: 4 DL symbols + 6 guard symbols + 4 UL symbols

Frame length

Cambium PMP devices support 2.5 ms and 5 ms frame lengths. 5G-NR options supported for co-location must also have a frame duration of either 2.5 ms or 5 ms.

Out of the options listed above, the first becomes selectable if the PMP frame length is configured as 2.5 ms, while the last two become selectable if the PMP frame length is configured as 5 ms.

Frame start

The Cambium PMP Radio configuration page offers a co-location with 5G-NR option in the GUI Radio page, that allows the user to co-locate Cambium PMP devices with 5G-NR devices by shifting the start of the PMP frame to match the start of the 5G-NR frame.

The Co-located Frame Configuration Option is available in the Configuration → Radio page, in the Frame Configuration section. The options in the drop-down menu depend on the Frame Period selected for the device.

If the Frame Period is selected as 2.5 ms, the options in the Co-located Frame Configuration Option are:

- Disable
- 5G-NR Frame DDDSU

Figure 77: Co-location options with 2.5 ms frame

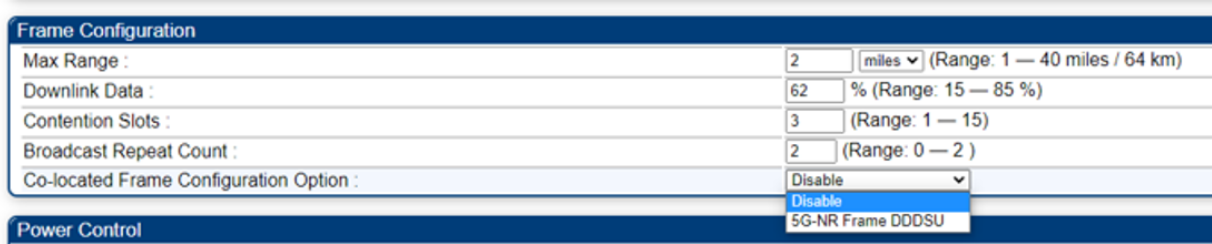

If the Frame Period is selected as 5 ms, the options in the Co-located Frame Configuration Option are:

- Disable
- LTE Frame Configuration 0
- LTE Frame Configuration 1
- LTE Frame Configuration 2
- 5G-NR Frame DDDDDDSUU

Figure 78: Co-location options with 5 ms frame

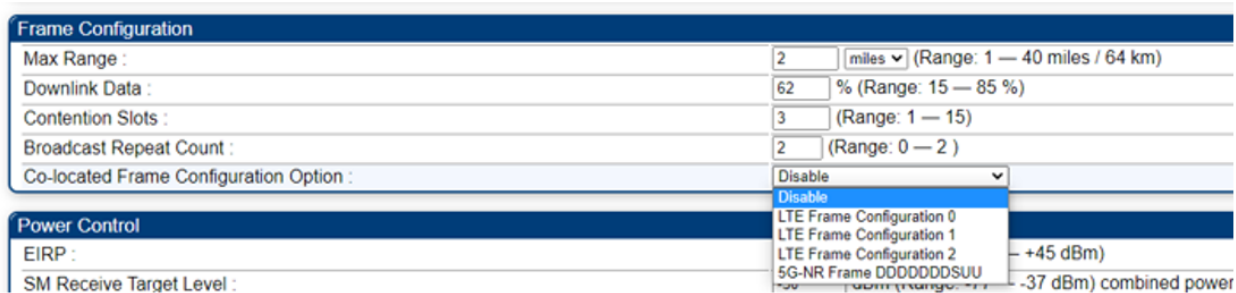

If the 5G-NR frame is selected, after saving the selection, a new field becomes available. The Co-located 5G-NR Guard Symbols offer a selection between 4 or 6 guard symbols in the S subframe.

Figure 79: Selection of guard symbols in 5 ms 5G-NR frame

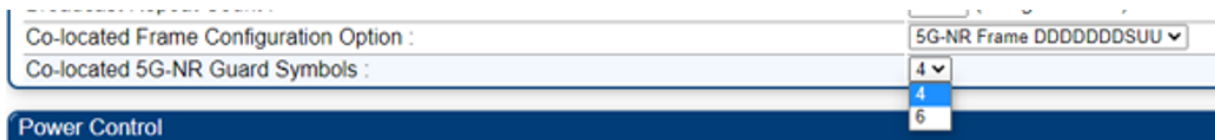

If the co-location option is disabled, then the Cambium PMP frame start is not shifted from its default timing.

If co-location with one of the 5G-NR frames is selected, the Cambium PMP frame start is shifted to align with the selected 5G-NR frame start.

The Cambium PMP frame always starts with the downlink portion of the frame, followed by the turnaround time and then the uplink portion of the frame. This is not always the case with the 5G-NR frame. For example,

the 5G-NR 5 ms frame has this structure over a 10 ms period: DDDSUUDDDD DDDSUUDDDD. To align the Cambium PMP frame to this 5G-NR frame, the downlink start has to align to the beginning of subframe 6, not subframe 0. With this shift, the sequence of subframes in the 5G-NR frame becomes DDDDDDDSUU DDDDDDDSUU, which is the same structure as the Cambium PMP frame (downlink, turnaround time, uplink).

When selecting one of the 5G-NR frame configuration options, a shift is applied to the Cambium PMP frame to correctly line up with the selected LTE 5G-NR frame.

Automatic duty-cycle adjustment

When co-location with one of the 5G-NR frames is selected, the PMP radio automatically calculates the range of Downlink Data that allows for co-location. The default range of 15-85% is modified to reflect the new allowed range.

Figure 80 shows an example where the allowed range for Downlink Data (duty cycle) is restricted to 78%-85% to guarantee successful co-location with the selected 5G-NR frame.

Figure 80: Reduced duty cycle range

Frame Configuration	
Max Range :	2 miles (Range: 1 — 40 miles / 64 km)
Downlink Data :	80 % (Range: 78 — 85 %)
Contention Slots :	3 (Range: 1 — 15)
Broadcast Repeat Count :	2 (Range: 0 — 2)
Co-located Frame Configuration Option :	5G-NR Frame DDDDDDDSUU
Co-located 5G-NR Guard Symbols :	4

PMP–5G-NR co-location tool

When selecting a co-location with a 5G-NR frame, the radio automatically adjusts the Downlink Data parameters to avoid interference. However, other parameters affect the PMP frame structure, and the user could adjust some of those parameters instead of or in addition to just changing the duty cycle.

To help with the selection of system parameters, Cambium Networks offers a PMP – 5G-NR co-location tool, available at <https://support.cambiumnetworks.com/files/colocationtool/>.

The PMP and 5G-NR configuration parameters are entered in the spreadsheet, and the frame structure for the two systems is displayed on the right side.

The tool checks that there is no overlap between one AP transmitting and the other receiving.

This translates into two equations:

- The downlink time of AP1 ends before the uplink time of AP2 starts
- The downlink time of AP2 ends before the uplink time of AP1 starts

In the example in Figure 81 the second equation is not satisfied, and the two systems cannot be co-located. The plot to the right also shows that with this frame configuration, the 5G-NR AP is still transmitting when the PMP AP is already receiving. This creates interference at the PMP AP receiver.

Figure 81: Example of PMP – 5G-NR co-location with invalid parameters

PMP - 5G-NR co-location tool					
PMP Configuration		5G-NR Configuration			
Mode	PMP	Frame Configuration	DDDDDDSUU		
Channel Bandwidth (MHz)	20	Guard symbols	4		
Max Range (mi)	5				
Downlink Data	75%				
Contention slots	4				
Frame Period (ms)	5				
PMP Timing (ms)		5G-NR Timing (ms)			
DL end	3.466	DL end	3.714		
UL start	3.651	UL start	3.857		
CHECKS					
PMP DL end	3.466	<	5G-NR UL start	3.857	OK
5G-NR DL end	3.714	<	PMP UL start	3.651	OK

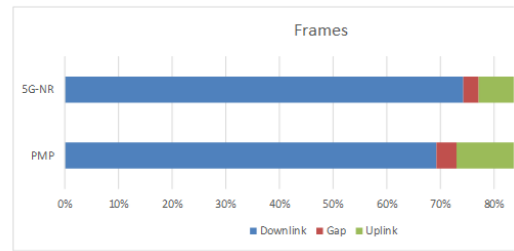

Using the tool, parameters can be updated to find a set of values that allows for co-location.

For example, changing the duty cycle of the PMP AP from 75% to 80% makes both equations true, and there is no longer an overlap between one AP transmitting and the other receiving.

Figure 82: Example of PMP – 5G-NR co-location with valid parameters

PMP - 5G-NR co-location tool					
PMP Configuration		5G-NR Configuration			
Mode	PMP	Frame Configuration	DDDDDDSUU		
Channel Bandwidth (MHz)	20	Guard symbols	4		
Max Range (mi)	5				
Downlink Data	80%				
Contention slots	4				
Frame Period (ms)	5				
PMP Timing (ms)		5G-NR Timing (ms)			
DL end	3.684	DL end	3.714		
UL start	3.870	UL start	3.857		
CHECKS					
PMP DL end	3.684	<	5G-NR UL start	3.857	OK
5G-NR DL end	3.714	<	PMP UL start	3.870	OK

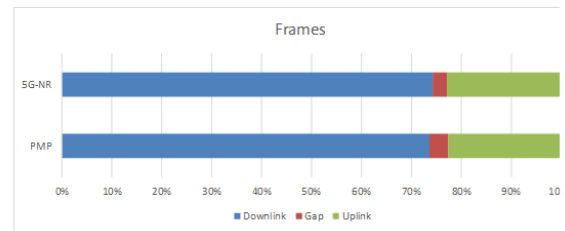

Another option is to select the 5G-NR frame with 6 guard symbols instead of 4. The PMP duty cycle can be left at 75%, but now the second equation is also true and there is no interference between the two APs.

Figure 83: Another example of PMP - 5G-NR co-location with valid parameters

PMP - 5G-NR co-location tool					
PMP Configuration		5G-NR Configuration			
Mode	PMP	Frame Configuration	DDDDDDSUU		
Channel Bandwidth (MHz)	20	Guard symbols	6		
Max Range (mi)	5				
Downlink Data	75%				
Contention slots	4				
Frame Period (ms)	5				
PMP Timing (ms)		5G-NR Timing (ms)			
DL end	3.466	DL end	3.643		
UL start	3.651	UL start	3.857		
CHECKS					
PMP DL end	3.466	<	5G-NR UL start	3.857	OK
5G-NR DL end	3.643	<	PMP UL start	3.651	OK

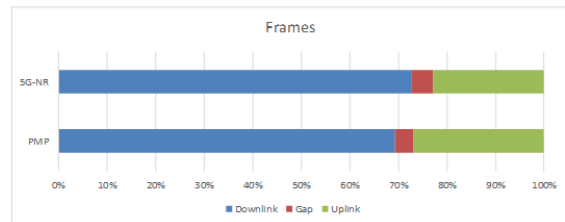

Multiple OFDM AP Clusters

When deploying multiple AP clusters in a dense area, consider aligning the clusters as shown in [Figure 84](#). However, this is only a recommendation. The specific requirements of an installation may dictate a different pattern of channel assignments.

Figure 84: Example layout of 16 AP sectors (ABCD), 90-degree sectors

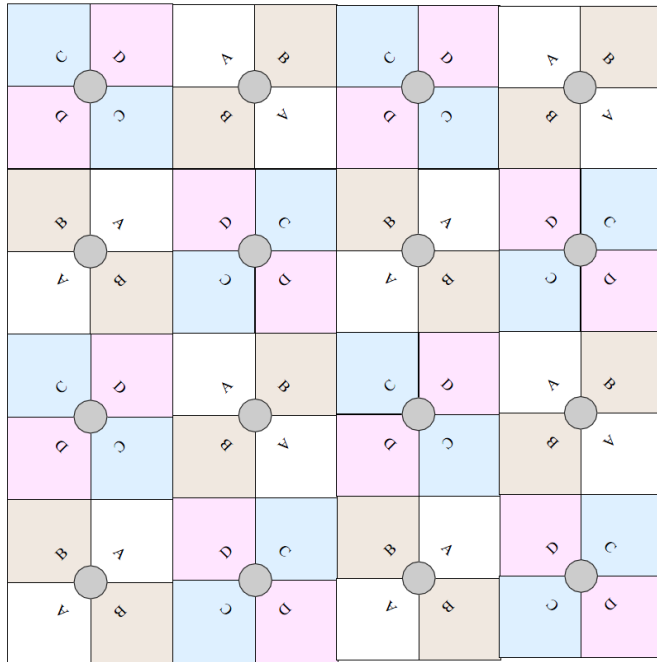

An example of frequency channel assignments is provided in [Table 122](#).

Table 122: Example 5.8 GHz 4-channel assignment by access site

Symbol	Frequency
A	5.740 GHz
B	5.780 GHz
C	5.760 GHz
D	5.800 GHz

Figure 85: Example layout of 6 AP sectors (ABC), 60-degree sectors

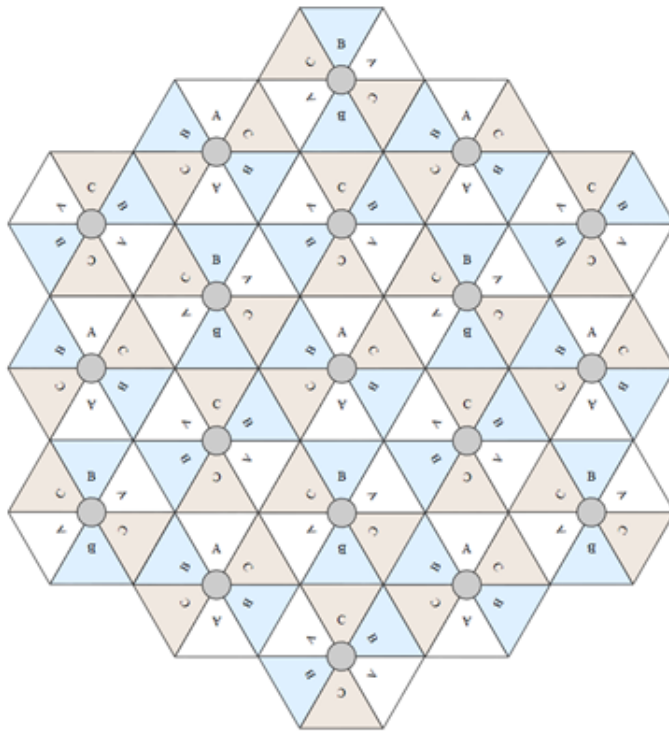

An example for assignment of frequency channels and sector IDs is provided in [Table 123](#).

Table 123: Example 5.8 GHz 3-channel assignment by access site

Symbol	Frequency
A	5.740 GHz
B	5.760 GHz
C	5.780 GHz

Considerations on back-to-back frequency reuse

When considering back-to-back frequency reuse, Cambium Networks recommends employing the ABAB frequency reuse pattern, ([Figure 85](#) in the example layout of 16 AP sectors (ABCD) with 90-degree sectors). This approach allows for the creation of a base site with four sectors using only two frequencies, which is particularly effective in situations where high capacity is needed within a limited spectrum.

To implement this plan successfully, the following conditions must be met:

1. **GPS synchronization:** All APs must transmit simultaneously.
2. **Uplink and Downlink timings:** Timings across APs must not overlap, and adjustments can be made using Cambium's frame calculators and co-location tools.

3. **Uplink power control:** Ensure that all signals are received on the uplink at the same level; this feature is typically enabled on all sectors.
4. **Absence of reflecting objects:** There must be no large reflecting objects within the exclusion zones defined in this section.
5. **Line-of-Sight (LoS):** SMs must not have a typical line-of-sight to an interfering base station. In the example layout of 16 AP sectors, the worst-case range ratio is 5:1, providing only 14 dB protection in LoS, which falls short of the required 30 dB for 256QAM capability. Down tilt can be beneficial when the elevation beamwidth is low. Additionally, the range ratio varies for shorter distance SMs, offering better performance. While this frequency reuse plan may not always achieve 256QAM for the longest distance SMs, it often strikes a good balance between spectrum utilization and guaranteed modulation rates."

Reflecting objects

Figure 86 presents two depictions of the same reflecting object. In the **Uplink Interference** scenario, two SMs are transmitting simultaneously. SM2 must ideally be received cleanly by AP for Sector 3. However, interference may arise from SM1 via the reflecting object, leading to a lower Signal-to-Interference ratio than what is required at AP3. This interference can result in either transmission errors, which may be corrected by Automatic Repeat Request (ARQ), or a reduction in the selected modulation rate. Either of these outcomes can lead to decreased throughput from SM2, affecting Sector 3's performance.

In the **Downlink Interference** scenario, AP3 interferes with SM1. Once again, this interference may result in reduced transmission due to errors or a lower modulation rate.

Figure 86: Reflection

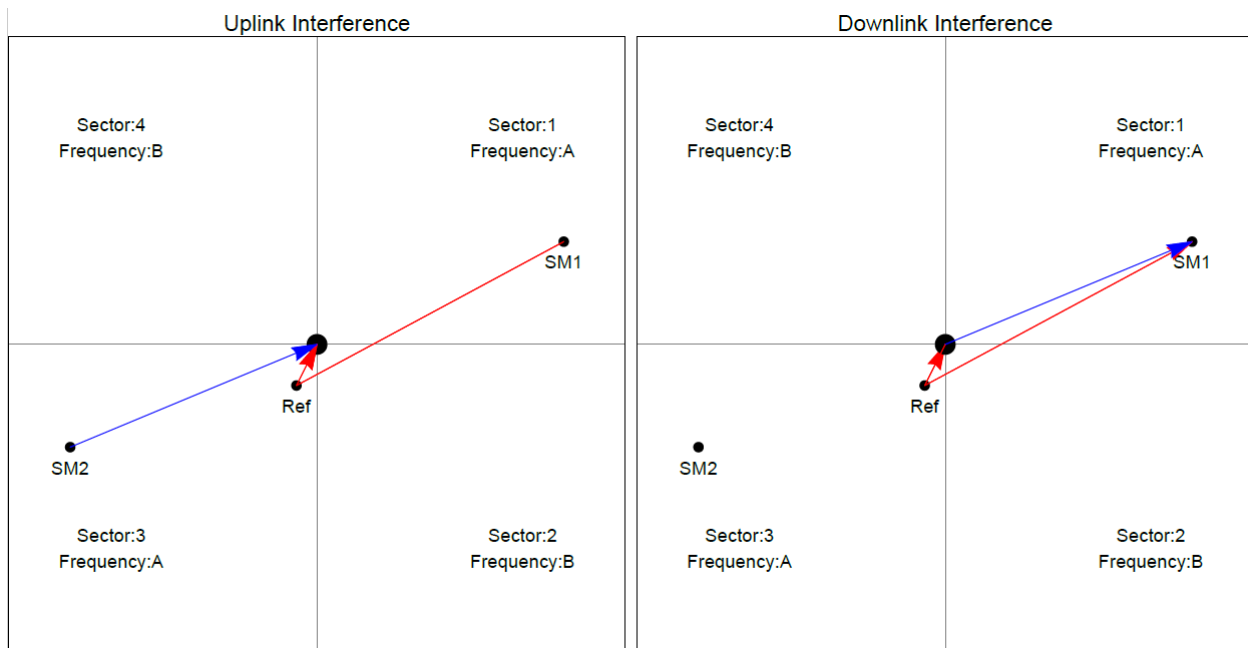

Reflection likelihood guidance

As demonstrated in the previous section, reflection has the potential to reduce throughput in an ABAB base site. This section provides guidance on assessing the likelihood of interference caused by reflections. The primary condition for reflections to impact data rates is that the reflecting object must be within the line of sight of both the AP and the SM for signal re-transmission to occur. If this condition is not met, the object cannot cause interference.

Assuming that the potential reflecting object is visible to both the AP and the SM, several factors come into play, including object sizes and specific zones where we can anticipate interference that may affect throughput when both Sector 1 and Sector 3 are transmitting data.

The **Sector Antenna** and **cnMedusa Antenna** diagrams depict regions labeled as A, B, C, and D. In addition, we must consider objects of varying sizes, denoted as 1, 2, 3, and 4, and define the areas where these objects may potentially interfere:

- Object Size 1: Represents a flat building face with clear reflecting properties from the sector to the AP.
- Object Size 2: Encompasses random metal structures, such as wireless towers.
- Object Size 3: Refers to a flat metallic face or tree measuring 0.5 x 0.5 meters.
- Object Size 4: Includes random metal structures measuring 0.2 x 0.2 meters or foliage measuring 0.5 x 0.5 meters.

The conditions for no interference are:

- size 2 outside zone B
- size 3 outside zone C
- size 4 outside zone D

Object Size 1 has the potential to cause interference at relatively large distances. It's essential to examine the geometry of how reflections could occur and lead to interference. Typically, this phenomenon occurs within a limited range of azimuth angles and distances.

Figure 87: Sector Antenna

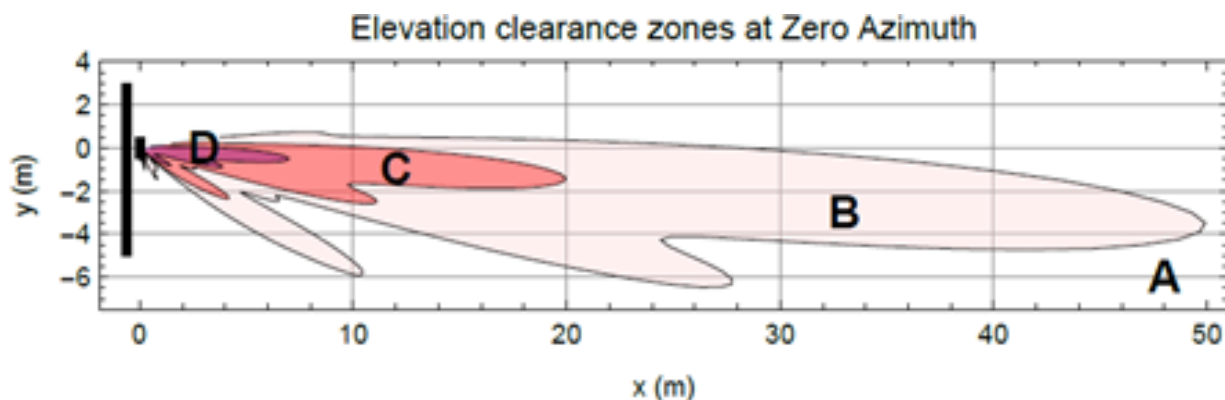

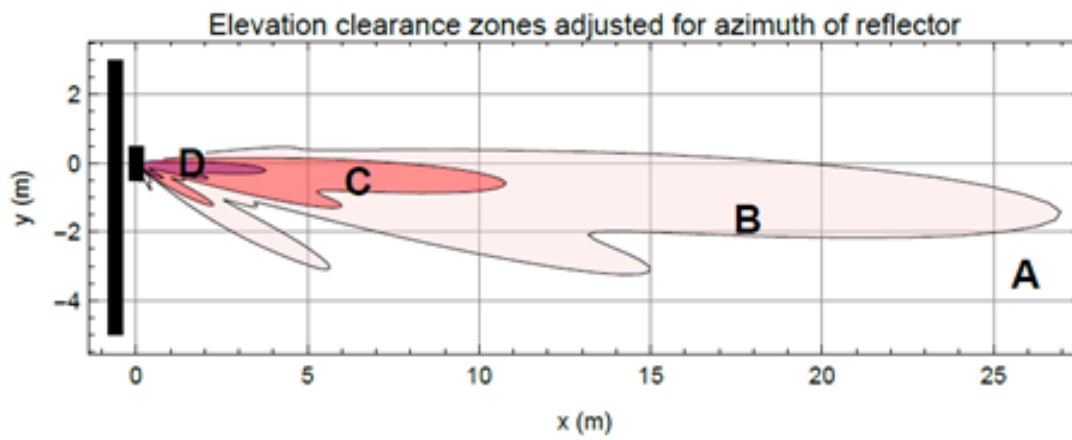
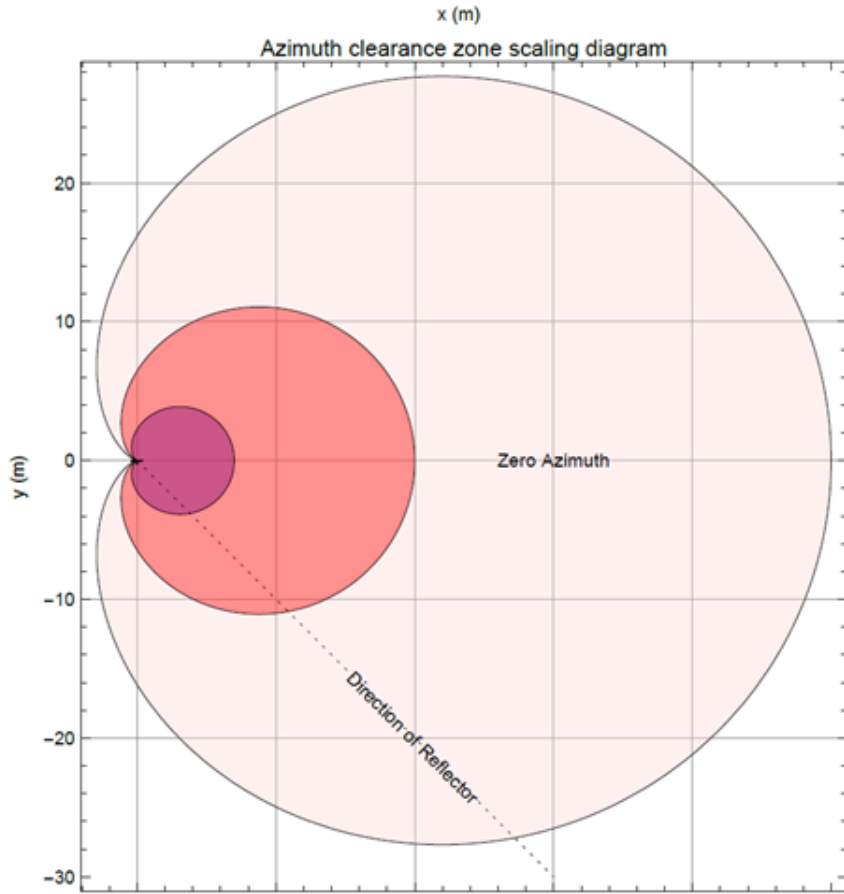
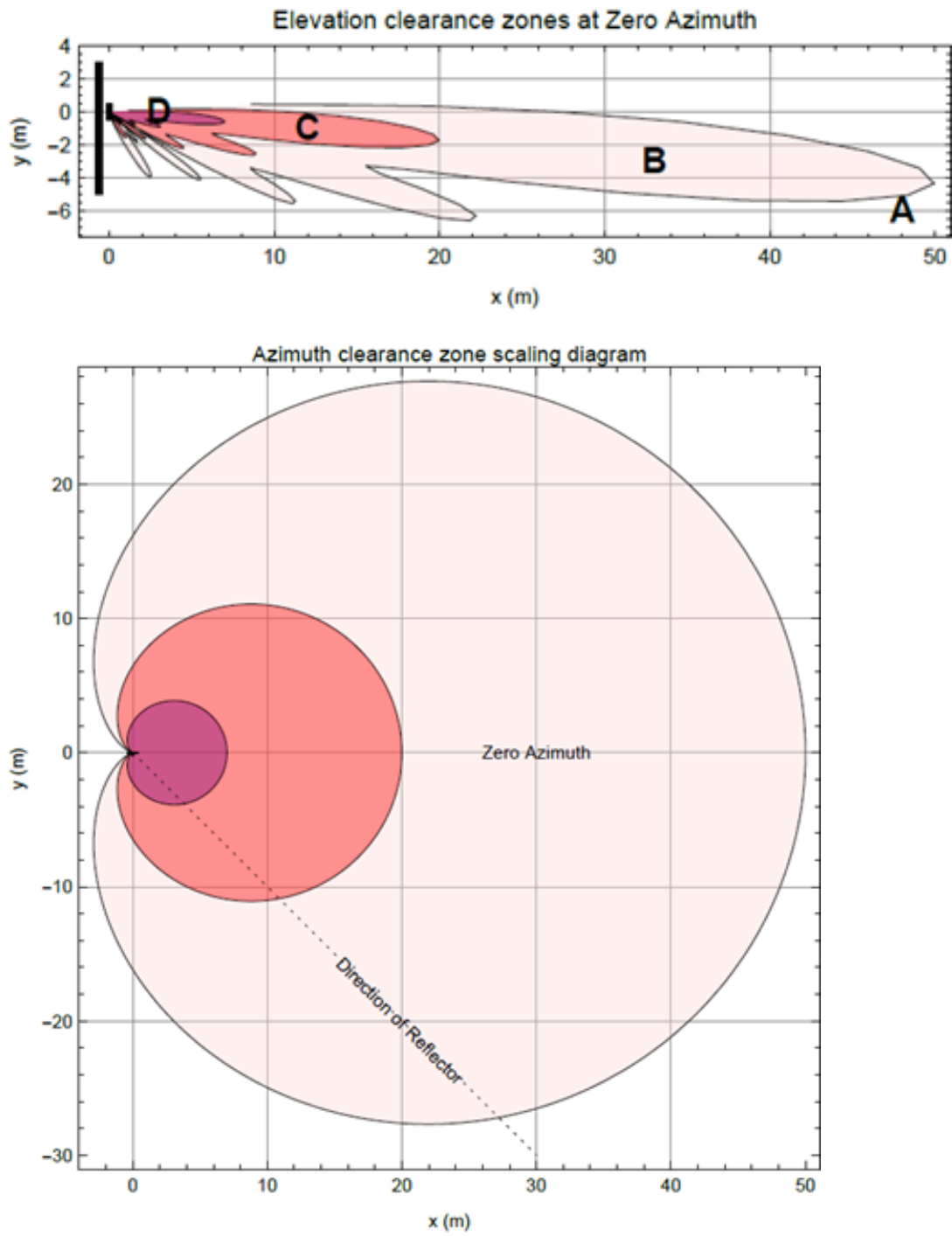
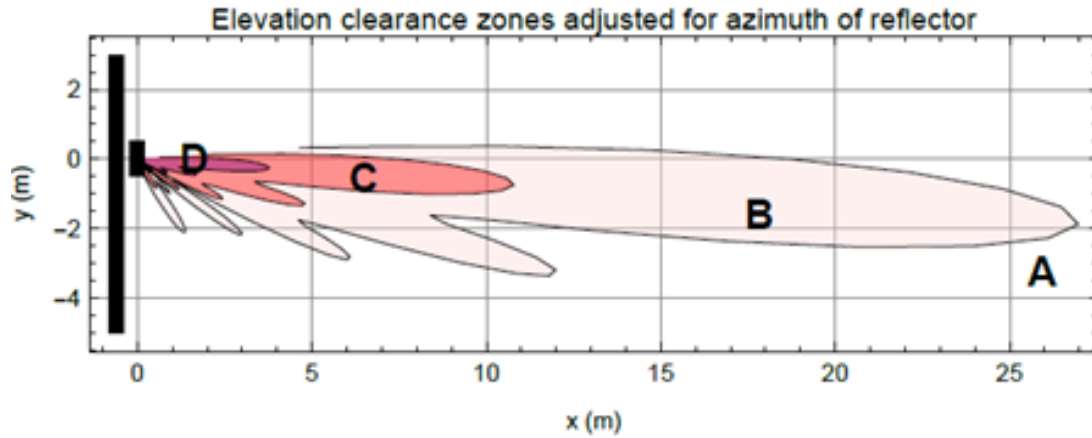

Figure 88: *cnMedusa* Antenna





Both the Sector Antenna and cnMedusa Antenna have three figures with measurements scaled in meters, assuming a typical down tilt of 4°.

In each set of figures:

- The top figure illustrates the clearances required at zero azimuth.
- The middle figure shows the scaling required in relation to the top Figure to account for variations in the azimuth of the reflecting object.
- The bottom figure is a scaled version of the top figure, factoring in the dotted azimuth line from the middle figure.

The PMP 450m Series AP is built on Massive MU-MIMO technology. The 5 GHz 450m features a 14x14 MIMO system, enabling simultaneous communication with up to seven SMs. The 3 GHz 450m utilizes an 8x8 MIMO system, allowing simultaneous communication with up to four SMs.

Figure 89: PMP 450m Series AP antenna beam

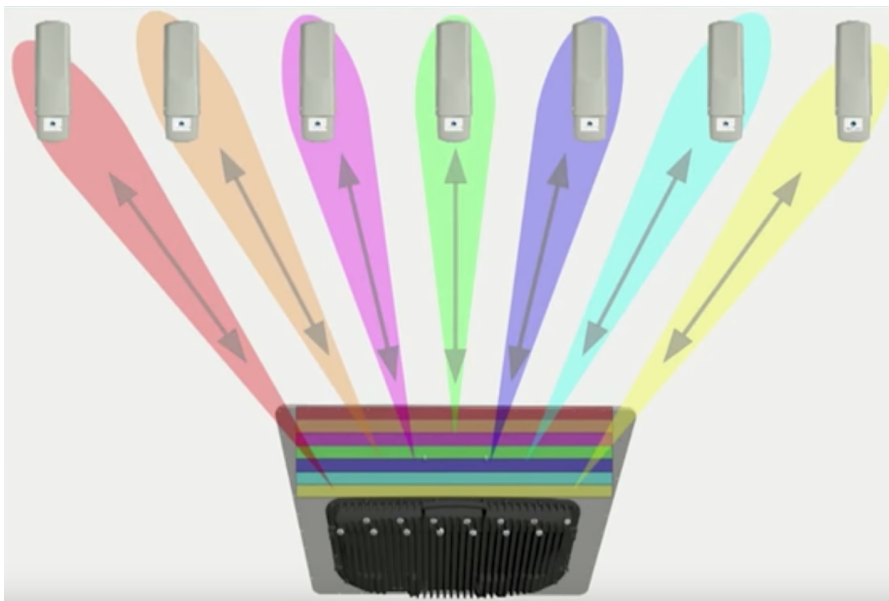

PMP 450m installation recommendations

- For optimal performance, it is advisable to maintain a clearance zone around the mast. The size of this clearance zone varies depending on the surrounding environment and the down tilt of the antenna. In situations where the mast is surrounded by metal structures, a larger clearance is necessary compared to areas with foliage.
- To achieve the best results, spread the SMs evenly across the azimuth of the AP antenna.
- The PMP 450m is sensitive to movement. To ensure the highest MU-MIMO performance, it is strongly recommended to mount or install the PMP 450m AP on a mast that is exceptionally rigid, with no movement, and oriented vertically.
- For efficient SM placement across the azimuth of the AP antenna, consider using LINKPlanner, a planning tool designed for this purpose.

Link planning

Link planning is crucial for successful wireless communication deployments. Factors like range, obstacle clearance, path loss, and expected throughput play significant roles in designing effective links. It's highly recommended to use LINKPlanner, a specialized tool, to facilitate this process efficiently.

Range and obstacles

Range and obstacle assessment are crucial factors when planning a link deployment. Consider these key considerations:

1. **Calculate link range:** Determine the range between the AP and SM to establish the link feasibility. This calculation must consider factors like desired throughput, frequency band, and available power.
2. **Obstacle identification:** Conduct a comprehensive survey of the installation area to identify potential obstructions along the radio path. These obstructions may include trees, buildings, or other structures.
3. **Assess obstruction impact:** Assess the impact of identified obstacles on radio performance. Obstructions can disrupt line-of-sight (LoS) and create non-line-of-sight (NLoS) conditions. NLoS environments have obstacles that block the optical line-of-sight between antennas.
4. **NLoS and OFDM:** Understand that the 450 Platform Family is designed to operate in both NLoS and LoS environments. OFDM (Orthogonal Frequency-Division Multiplexing) technology can mitigate the effects of NLoS by utilizing multipath propagation. It's particularly effective when obstacles are positioned in the middle of the link path, but less so when they are closer to the ODU.
5. **Frequency bands:** Consider the frequency band you're operating in. Higher frequency bands like 5.4 GHz and 5.8 GHz are more susceptible to attenuation through walls and obstacles like trees and buildings. Lower frequency bands, such as 900 MHz, offer better penetration through obstacles and

are well-suited for NLoS scenarios.

6. **Penetration expectations:** Even with OFDM technology, it's important to note that products in the 5.4 GHz and 5.8 GHz bands are not expected to penetrate walls or dense foliage effectively. For applications requiring obstacle penetration, especially in NLoS situations, 900 MHz radios are a more suitable choice.

By thoroughly evaluating these factors, you can make informed decisions about the link feasibility, antenna placement, and radio frequency band selection for your deployment. This helps optimize performance and minimizes the impact of obstacles on your wireless network.

Path loss

Path loss is a critical factor that measures the attenuation of a radio signal as it travels between two points in a wireless link. It encompasses several components, including:

1. **Free Space Path Loss (FSPL):** This represents the theoretical attenuation of a signal if there were no obstacles or interference along the path. It is calculated based on the basic properties of radio waves, including frequency and distance.
2. **Excess path loss:** This accounts for the additional attenuation caused by obstacles such as buildings, trees, and other structures in the signal path. It quantifies the impact of physical obstructions on the signal's strength.
3. **Fade margin:** To ensure reliable communication, a margin is added to account for signal fading due to environmental factors like weather conditions, interference, or signal variations. This margin provides a buffer against potential signal degradation.

To determine the feasibility of a wireless link, you must perform a comprehensive calculation that considers these factors. This calculation helps assess whether the link can be successfully established, accounting for the inherent challenges posed by the physical environment and potential signal fluctuations.

By evaluating these aspects, you can make informed decisions about link planning, antenna placement, and the selection of appropriate equipment to ensure reliable wireless communication between the two endpoints. The following calculation needs to be performed to judge whether a link can be installed:

$L_{free_space} + L_{excess} + L_{fade} + L_{seasonal} < L_{capability}$	
Where:	Is:
L_{free_space}	Free Space Path Loss (dB)

L_{excess}	Excess Path Loss (dB)
L_{fade}	Fade Margin Required (dB)
$L_{seasonal}$	Seasonal Fading (dB)
$L_{capability}$	Equipment Capability (dB)

Calculating Link Loss

The link loss is the total attenuation of the wireless signal between two point-to-multipoint units. The link loss calculation is presented below:

Link Loss (dB) = Transmit power of the remote wireless unit (dBm) - Tx Cable loss (dB) - Received power at the local unit (dBm) - Rx cable loss (dB) + Antenna gain at the remote unit (dBi) + Antenna gain at the local unit (dBi).

Calculating Rx Signal Level

The determinants in Rx signal level are illustrated in [System Planning](#). Below figure determinants in Rx signal level.

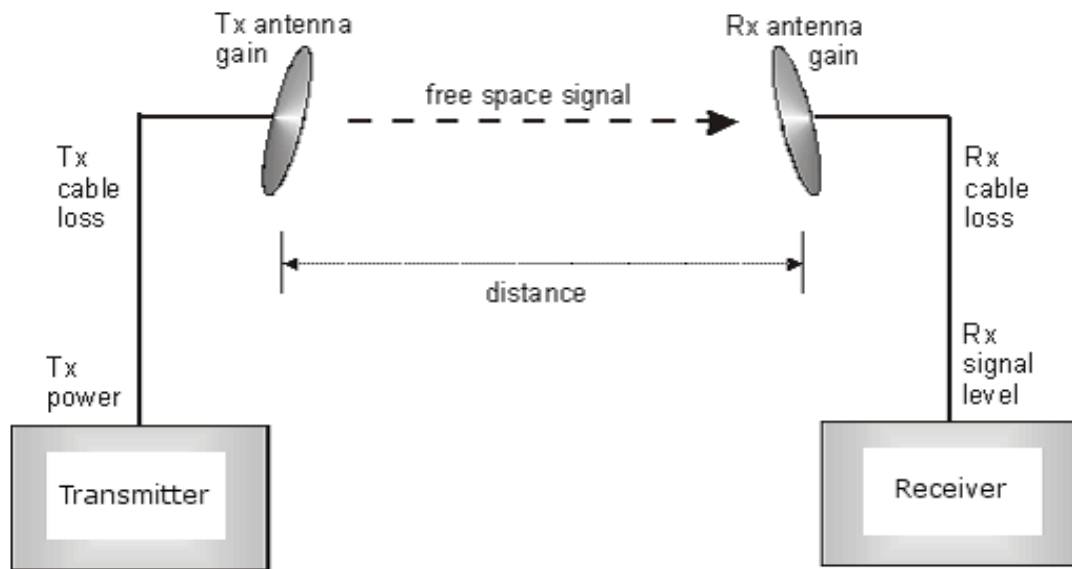

The Rx signal level (in dB) can be calculated using the following formula:

Rx Signal Level (dB) = Tx Power (dBm) - Tx Cable Loss (dB) + Tx Antenna Gain (dBi) - Free Space Path Loss (dB) + Rx Antenna Gain (dBi) - Rx Cable Loss (dB).



Note

The Rx signal level calculation presumes that a clear line of sight is established between the transmitter and receiver and that no objects encroach in the Fresnel zone.

Calculating fade margin

Free space path loss is a significant factor in determining the received (Rx) signal level. The Rx signal level, in turn, plays a crucial role in calculating the system's operating margin, also known as the fade margin. The calculation for fade margin is as follows:

System operating margin (fade margin) dB = Rx signal level dB – Rx sensitivity dB

The fade margin represents the difference between the strength of the received signal and the strength required by the receiver to maintain a reliable link. A higher fade margin indicates a more reliable link.

Adaptive modulation

Adaptive modulation ensures that the highest achievable throughput is obtained, taking into account factors such as propagation and interference. After the link installation, web pages provide real-time information about the measured link loss, both instantaneous and averaged. To assess the link's radio reliability, the averaged value must include the maximum seasonal fading. Detailed information about system throughput,

link loss, and maximum distance for each frequency band in all modulation modes can be found in the *Configuration Guide*.

Planning for connectorized units

This section describes factors to be considered when planning to use connectorized ODUs with external antennas in 450 Platform Family links.

When to install connectorized units

Most of radio links can be successfully deployed with the integrated ODU. However, the integrated units may not be sufficient in some areas, for example:

- Where the path is heavily obscured by dense woodland on an NLOS link.
- Where long LoS links are required.
- Where there are known to be high levels of interference.

In these areas, connectorized ODUs and external antennas must be used.

Choosing external antennas

When selecting external antennas, consider the following factors:

- The required antenna gain.
- Ease of mounting and alignment.
- Use dual-polarization antenna (as the integrated antenna).



Note

When using the Installation Wizard, input the antenna gain and cable loss. If the selected country has an EIRP limit, the unit automatically calculates the corresponding maximum transmit power.

Calculating RF cable length (5.8 GHz FCC only)

The FCC approval for the 5.8 GHz band for this product is based on tests conducted with a cable loss between the ODU and antenna not less than 1.2 dB. If the cable loss falls below 1.2 dB when using a 1.3 m (4 ft) diameter external antenna, the connectorized 450 Platform Family may exceed the maximum radiated spurious emissions allowed under FCC 5.8 GHz rules.

The cable loss primarily depends on the cable type and length. To ensure compliance with or exceeding the minimum loss requirement of 1.2 dB, it is crucial to use cables of the type and length specified in the document titled "RF Cable Lengths Required to Achieve 1.2 dB Loss at 5.8 GHz" (source: Times Microwave). This data excludes connector losses.

Table 124: RF cable lengths required to achieve 1.2 dB loss at 5.8 GHz

RF cable type	Minimum cable length
LMR100	0.6 m (1.9 ft)
LMR200	1.4 m (4.6 ft)
LMR300	2.2 m (7.3 ft)
LMR400	3.4 m (11.1 ft)
LMR600	5.0 m (16.5 ft)



Note

In cases where the IP address set in the module does not fall within the 169.254.x.x network address range, it becomes necessary for the network operator to assign the computer a static IP address within the same subnet.

Data network planning

This section describes factors to be considered when planning 450 Platform Family data networks.

Understanding addresses

A basic understanding of Internet Protocol (IP) address and subnet mask concepts is required for engineering your IP network.

IP address

The IP address consists of a 32-bit binary number divided into four parts, commonly referred to as octets. These four octets are further segmented based on the class of the IP address. The first segment is responsible for identifying the network, while the second segment is used to identify the hosts or devices connected to that network. The subnet mask plays a crucial role in delineating this boundary between the network and its associated devices.

Dynamic or static addressing

To enable communication between a computer and a module, the computer must be configured with one of the following options:

1. **Dynamic Host Configuration Protocol (DHCP):** When utilizing DHCP, the computer automatically acquires an IP address, typically within the 169.254 network, if it is not connected to a network. This assignment usually occurs within two minutes.

2. **Static IP address assignment:** Alternatively, you can manually assign a static IP address to the computer, such as 169.254.1.5, within the 169.254 network.

When a DHCP server is not found

For a computer to function on a network, it requires essential configuration information, including an IP address, subnet mask, and possibly a gateway address. This configuration can either be automatically provided by a DHCP server when a computer connects to a network, or it must be manually entered by an operator.

In situations where a computer is brought online, but a DHCP server is not accessible (perhaps due to server downtime or the computer being disconnected from the network), Microsoft and Apple operating systems employ a default configuration. They assign the computer an IP address within the 169.254.x.x range and use a subnet mask of 255.255.0.0 (which corresponds to the subnet 169.254/16, where /16 signifies that the first 16 bits of the address range are identical across all devices in the subnet).

DNS Client

The DNS Client serves the purpose of resolving names for management servers within the operator's management domain, as described in the Cambium Networks Management Domain. This feature facilitates hostname configuration for various servers, including NTP servers, Authorization Servers, DHCP relay servers, and SNMP trap servers. Operators have the option to either input the Fully Qualified Domain Name (FQDN) for the hostname or manually specify the IP addresses of these servers.

Figure 90: Cambium networks management domain

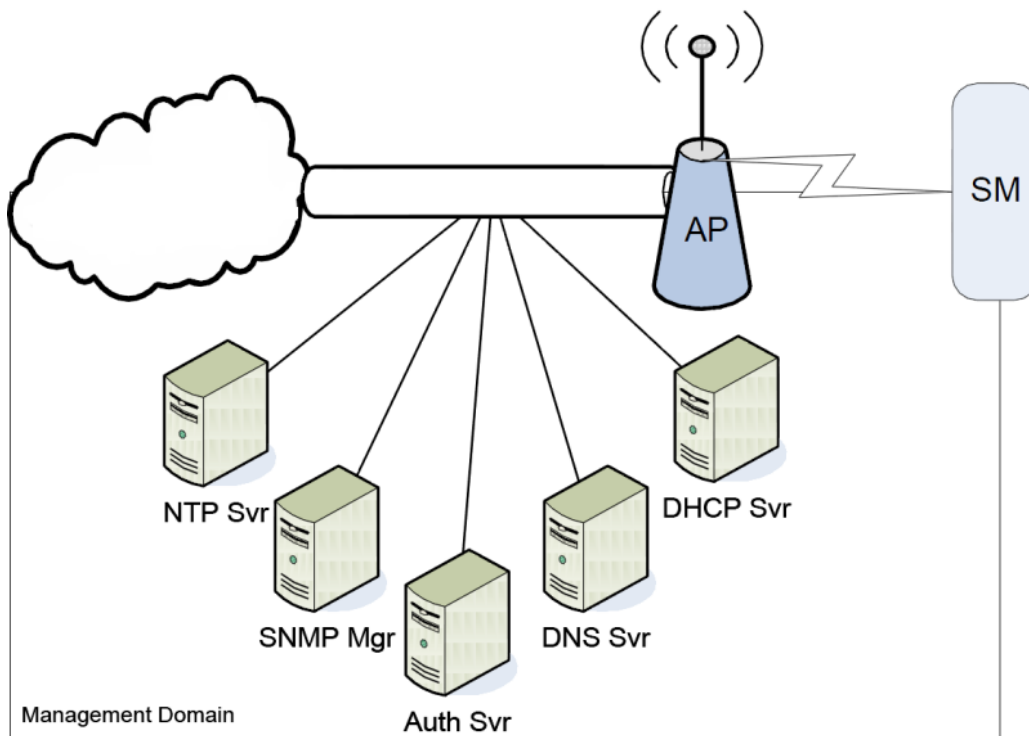

Network Address Translation (NAT)

NAT, DHCP Server, DHCP Client and DMZ in SM

The system provides NAT (network address translation) for SMs in the following combinations of NAT and DHCP (Dynamic Host Configuration Protocol):

- NAT Disabled
- NAT with DHCP Client (DHCP selected as the Connection Type of the WAN interface) and DHCP Server
- NAT with DHCP Client (DHCP selected as the Connection Type of the WAN interface)
- NAT with DHCP Server
- NAT without DHCP

Network Address Translation (NAT)

NAT serves the purpose of isolating devices connected to the Ethernet/wired side of a SM from being directly visible from the wireless side of the SM. When NAT is enabled, the SM is assigned an IP address for handling transport traffic (distinct from its management address). It acts as a termination point for transport traffic and allows you to allocate a range of IP addresses to devices connected to the Ethernet/wired side of the SM.

Within the Cambium system, NAT supports a wide array of protocols, including HTTP, ICMP (Internet Control Message Protocol), and FTP (File Transfer Protocol). For virtual private network (VPN) setups, it offers support for L2TP over IPSec (Layer 2 Tunneling Protocol over IP Security) and PPTP (Point-to-Point Tunneling Protocol).

Dynamic Host Configuration Protocol (DHCP)

DHCP enables a device to automatically receive a new IP address and TCP/IP parameters, including a default gateway, whenever the device reboots. This streamlines configuration, conserves IP addresses, and facilitates the relocation of modules to different networks within the Cambium system.

In combination with NAT features, each SM offers:

- A DHCP server that allocates IP addresses to computers connected to the SM via Ethernet protocol.
- A DHCP client that obtains an IP address for the SM from a network DHCP server.

DMZ (Demilitarized Zone)

When combined with the NAT features, a DMZ (demilitarized zone) permits the allocation of one IP address behind the SM, allowing a device to function logically outside the firewall and receive network traffic. The first three octets of this IP address must match the first three octets of the NAT private IP address.

Developing an IP addressing scheme

Network elements are accessed through IP Version 4 (IPv4) addressing. Establishing an appropriate IP addressing scheme is crucial for the efficient operation and security of a network.

Each module necessitates an IP address within the network, which is exclusively designated for management purposes. For security considerations, you must adhere to one of the following practices:

1. Assign a non-routable IP address.
2. Assign a routable IP address only when a firewall is present to safeguard the module.

Allocate IP addresses to computers and network components using either static or dynamic IP addressing methods. Additionally, configure the appropriate subnet mask and network gateway for each module.

Address Resolution Protocol (ARP)

ARP plays a crucial role in network communication, as previously mentioned. The MAC address serves to identify a module in several key aspects:

1. Communications between modules.
2. Storing data about other modules.

While the IP address is vital for data delivery through a router interface, ARP is responsible for mapping MAC addresses to IP addresses. Here's how ARP functions in the context of network communication:

When a communication request needs to traverse beyond the local network segment, ARP retrieves the network gateway address of the router and translates it into the corresponding MAC address of the router. Subsequently, the communication is directed to the MAC address associated with the router's physical network interface card (NIC).

This process repeats for each router encountered between the sending module and its destination. The ARP correlation information is stored temporarily in an ARP cache until it times out.

Allocating subnets

The subnet mask is a 32-bit binary number that serves as a filter for the IP address. In the subnet mask, each bit set to 1 corresponds to a bit in the IP address that is part of the network address.

Example IP address and subnet mask

In [Example of IP address in Class B subnet](#), the first 16 bits of the 32-bit IP address identify the network:

Figure 91: Example of IP address in Class B subnet

	Octet 1	Octet 2	Octet 3	Octet 4
IP address 169.254.1.1	10101001	11111110	00000001	00000001
Subnet mask 255.255.0.0	11111111	11111111	00000000	00000000

In this example, the network address is 169.254 and 2^{16} (65,536) hosts are addressable.

Selecting non-routable IP addresses

Selecting non-routable IP addresses is crucial for network security. The factory default assignments for network elements are as follows:

- Unique MAC address
- IP address of 169.254.1.1
- Subnet mask of 255.255.0.0
- Network gateway address of 169.254.0.0

To ensure security, assign an IP address for each radio and CMM4/CMM5 that aligns with your network's IP addressing plan and cannot be accessed from the Internet. It's important to note that IP addresses within the following ranges are not routable from the Internet, regardless of whether a firewall is configured:

- 10.0.0.0 – 10.255.255.255
- 172.16.0.0 – 172.31.255.255
- 192.168.0.0 – 192.168.255.255

Additionally, you can configure the subnet mask and network gateway for each CMM4/CMM5 as needed for your network setup.

Translation bridging

As an optional configuration, the AP can be set to modify the source MAC address in every packet it receives from its SMs. This modification replaces the source MAC address with the MAC address of the SM/BHS that bridged the packet before forwarding it to the public network. When this feature is enabled:

1. The system allows a maximum of 128 IP devices to concurrently send data to the AP from behind the SM.
2. The SM maintains a Translation Table within the Statistics web page, which displays the MAC addresses and IP addresses of all valid connected devices.
3. Each entry in the Translation Table is accompanied by a timestamp indicating the number of minutes that have passed since the last packet transfer occurred between the connected device and the SM.
4. In scenarios where 128 devices are already connected, and another device attempts to connect, the following rules apply:
 - If there are no Translation Table entries older than 255 minutes, the new connection attempt is ignored.

- If an entry in the Translation Table exceeds 255 minutes in age, the oldest entry is removed to accommodate the new connection, making the attempt successful.
5. Additionally, the **Send Untranslated ARP** parameter, which can be configured in the **General** tab of the **Configuration** page, offers two options:
- Disabled: In this mode, the AP overwrites the MAC address in ARP packets before forwarding them.
 - Enabled: When enabled, the AP forwards ARP packets without overwriting the MAC address, regardless of previous modifications.

The **Translation Bridging** feature can be enabled or disabled through the General page of the Configuration web page in the AP. When this feature is disabled, the configuration of the "Send Untranslated ARP" parameter does not impact packet forwarding, as all packets are forwarded without modification (with the source MAC address intact). For more information, refer to the Address Resolution Protocol section.

Engineering VLANs

The radios support VLAN functionality as defined in the 802.1Q (Virtual LANs) specification, except for the following aspects of that specification:

- Protocols:
 - Generic Attribute Registration Protocol (GARP) GARV
 - Spanning Tree Protocol (STP)
 - Multiple Spanning Tree Protocol (MSTP)
 - GARP Multicast Registration Protocol (GMRP)
- Embedded source routing (ERIF) in the 802.1Q header
- Multicast pruning
- Flooding unknown unicast frames in the downlink
- As an additional exception, the AP/BHM does not flood downward the unknown unicast frames to the SM/BHS.

A VLAN configuration in Layer 2 establishes a logical group within the network. Each computer in the VLAN, regardless of initial or eventual physical location, has access to the same data. For the network operator, this provides flexibility in network segmentation, simpler management, and enhanced security.

Special case VLAN numbers

This system handles special case VLAN numbers according to IEEE specifications:

Table 125: Special case VLAN IDs

VLAN Number	Purpose	Usage Constraint
0	These packets have 802.1p priority, but are otherwise handled as untagged.	Must not be used as a management VLAN.
1	Although not noted as special case by IEEE specifications, these packets identify traffic that was untagged upon ingress into the SM and must remain untagged upon egress. This policy is hard-coded in the AP.	Must not be used for system VLAN traffic.
4095	This VLAN is reserved for internal use.	Must not be used at all.

SM membership in VLANs

With the supported VLAN functionality, the radios determine bridge forwarding on the basis of not only the destination MAC address, but also the VLAN ID of the destination. This provides flexibility in how SMs are used:

- Each SM can be a member in its own VLAN.
- Each SM can be in its own broadcast domain, such that only the radios that are members of the VLAN can see broadcast and multicast traffic to and from the SM.
- The network operator can define a work group of SMs, regardless of the AP(s) to which they register.

PMP 450 Platform Family modules provide the VLAN frame filters that are described in [VLAN filters in point-to-multipoint modules](#).

Table 126: VLAN filters in point-to-multipoint modules

Where VLAN is active, if this parameter value is selected ...	then a frame is discarded if...		because of this VLAN filter in the software:
	entering the bridge/ NAT switch through...		
any combination of VLAN parameter settings	Ethernet...	TCP/IP...	Ingress
	with a VID not in the membership table		

any combination of VLAN parameter settings		with a VID not in the membership table	Local Ingress
Allow Frame Types: Tagged Frames Only	with no 802.1Q tag		Only Tagged
Allow Frame Types: Untagged Frames Only	with an 802.1Q tag, regardless of VID		Only Untagged
Local SM Management: Disable in the SM, or All Local SM Management: Disable in the AP	with an 802.1Q tag and a VID in the membership table		Local SM Management
	leaving the bridge/ NAT switch through...		
	Ethernet	TCP/IP	
any combination of VLAN parameter settings	with a VID not in the membership table		Egress
any combination of VLAN parameter settings		with a VID not in the membership table	Local Egress

Priority on VLANs (802.1p)

The radios can prioritize traffic based on the eight priorities described in the IEEE 802.1p specification. When the high-priority channel is enabled on a SM, regardless of whether VLAN is enabled on the AP for the sector, packets received with a priority of 4 through 7 in the 802.1p field are forwarded onto the high-priority channel.

For example, when the high-priority and low-priority channels are enabled on an SM, the medium and ultra-high priority channels are disabled.

Operators may configure priority precedence as 802.1p Then Diffserv (Default) or Diffserv Then 802.1p. Since these priority precedence configurations are independent between the AP and SM, this setting must be configured on both the AP and SM to ensure that the precedence is adhered to by both sides of the link.

VLAN settings can also cause the module to convert received non-VLAN packets into VLAN packets. In this case, the 802.1p priority in packets leaving the module is set to the priority established by the DiffServ configuration.

If VLAN is enabled, it is essential to immediately monitor traffic to ensure that the results align with your desired outcomes. For example, high-priority traffic may potentially block low-priority traffic.

Q-in-Q DVLAN (Double-VLAN) Tagging (802.1ad)

PMP and PTP modules can be configured with 802.1ad Q-in-Q DVLAN (Double-VLAN) tagging, which is a method that enables an operator to encapsulate an 802.1Q VLAN within an 802.1ad VLAN. This nested VLAN, consisting of the original 802.1Q tag and a new second 802.1ad tag, facilitates the bridging of VLAN traffic across a network while segregating the broadcast domains of 802.1Q VLANs. Q-in-Q can be used in conjunction with PPPoE and/or NAT.

The 802.1ad standard defines the S-VLAN as the Service Provider VLAN and the C-VLAN as the customer VLAN. The radio software implements a two-layer Q-in-Q approach, where the C-VLAN represents the 802.1Q tag, and the S-VLAN is the second-layer Q tag, as shown in [Table 127](#).

Table 127: Q-in-Q Ethernet frame

Ethernet Header	S-VLAN EthType 0x88a8	C-VLAN EthType 0x8100	IP Data EthType 0x0800
-----------------	-----------------------	-----------------------	------------------------

The 802.1ad S-VLAN serves as the outer VLAN and is configurable on the **Configuration > VLAN** web page of the AP/BHM. The Q-in-Q EtherType parameter is pre-configured with a default EtherType of 0x88a8, along with four alternate EtherTypes that can be configured to enhance compatibility with existing networks that use different EtherTypes than the default.

The C-VLAN represents the inner VLAN tag, which aligns with the 802.1Q standard. In this top-level concept, the operation revolves around the outermost tag at any given time, either **pushing** a tag onto it or **popping** a tag off it. This implies that packets can transition at most from an 802.1Q frame to an 802.1ad frame (with a tag **pushed** on) or to an untagged 802.1 frame (with the tag **popped** off). Similarly, for an 802.1ad frame, the transition can only occur from an 802.1ad frame to an 802.1Q frame (with the tag **popped** off). This limitation exists because the radio software supports only two levels of tags.

Network management planning

This section describes how to plan for 450 Platform Family links to be managed remotely using SNMP.

Planning for Simple Network Management Protocol (SNMP) operation

In SNMP, Cambium modules provide various SNMP traps to notify a Network Management System (NMS) about specific events or conditions. These traps can be configured to automatically send notifications when certain events occur. Here's a breakdown of the SNMP traps provided by Cambium modules:

1. **authenticationFailure**: This trap signals that the SNMPv2c element has received a protocol message that is not properly authenticated. The generation of this trap may be contingent on the `snmpEnableAuthenTraps` object setting.

2. **linkDown**: This trap is defined in RFC 1573 and is typically sent when a network link goes down or becomes unavailable.
3. **linkUp**: Also defined in RFC 1573, this trap is sent when a network link is restored or becomes available after being down.
4. **egpNeighborLoss**: This trap, defined in RFC 1213, indicates a loss of neighborship with an Exterior Gateway Protocol (EGP) neighbor.
5. **whispGPSInSync**: This trap signals a transition from not synchronized to synchronized, typically related to GPS synchronization.
6. **whispGPSOutSync**: This trap signals a transition from synchronized to not synchronized in terms of GPS synchronization.
7. **whispRegComplete**: This trap indicates that the registration process has been completed successfully.
8. **whispRegLost**: This trap signals that registration has been lost, which could indicate a connection issue.
9. **whispRadarDetected**: This trap indicates radar detection during a one-minute scan, leading to a safety shutdown of the radio.
10. **whispRadarEnd**: This trap signals the end of a one-minute radar scan, during which radar was not detected, and the radio resumes normal operation.
11. **coldStart**: This trap signals that the SNMPv2c element is reinitializing itself, and its configuration may have been altered.
12. **warmStart**: This trap signals that the SNMPv2c element is reinitializing without altering its configuration.

These traps are essential for monitoring and managing Cambium modules remotely through an NMS. Network administrators can configure the NMS to respond to these traps appropriately, allowing for proactive network management and issue resolution. The specific traps that are enabled or configured can be adjusted based on the network's monitoring and management needs.



Note

The proprietary Management Information Bases (MIBs) for the 450 Platform Family are available for download from the support website of Cambium Networks. These MIBs are essential for managing and monitoring Cambium modules using SNMP (Simple Network Management Protocol). If you need access to these MIBs, you can refer to the support website or contact Cambium Networks for assistance on where to find and download them.

Enabling SNMP

To enable the SNMP (Simple Network Management Protocol) interface for use, configure the following attributes in the SNMP Configuration page of your device:

1. **SNMP state:** By default, this setting is disabled. Change it to enabled to activate SNMP functionality.
2. **SNMP version:** The default SNMP version is SNMPv2c. Depending on your requirements, choose a different SNMP version if needed, such as SNMPv3 for enhanced security.
3. **SNMP port number:** The default SNMP port number is 161. This port is used for SNMP communication. Leave it as is or change it to a different port number if necessary.

Configuring these attributes enables SNMP on your device, allowing you to monitor and manage it remotely using SNMP.

Security planning

This section describes how to plan for 450 Platform Family links to operate in secure mode.

- Port Configuration
- Managing module access by passwords
- Filtering protocols and ports

Isolating AP/BHM from the Internet

Ensure that the IP addresses of the AP/BHM in the network:

- Are not routable over the Internet.
- Do not share the subnet of the IP address of your user.

RFC 1918, Address Allocation for Private Subnets, reserves for private IP networks three blocks of IP addresses that are not routable over the Internet:

- /8 subnets have one reserved network, 10.0.0.0 to 10.255.255.255.
- /16 subnets have 16 reserved networks, 172.16.0.0 to 172.31.255.255.
- /24 subnets have 256 reserved networks, 192.168.0.0 to 192.168.255.255.

Encrypting radio transmissions

Cambium fixed wireless broadband IP systems employ the following form of encryption for security of the wireless link:

AES (Advanced Encryption Standard): An over-the-air link encryption option that uses the Rijndael algorithm and 128-bit keys to establish a higher level of security than DES. AES products are certified as compliant with the Federal Information Processing Standards (FIPS 197) in the U.S.A.

The default encryption setting for 450 Platform Family ODU is **None**.

Planning for HTTPS operation

Before starting to configure HTTPS operation, ensure that the cryptographic material listed in [HTTPS security material](#) is available.

Table 128: HTTPS security material

Item	Description	Quantity required
User Defined Security Banner	The banner provides warnings and notices to be read by the user before logging into the ODU. Use text that is appropriate to the network security policy.	Normally one per link. This depends upon network policy.
Port numbers for HTTP, HTTPS and Telnet	Port numbers allocated by the network.	As allocated by network.

Planning for SNMPv3 operation

Ensure secure SNMPv3 operation by choosing the appropriate security mode.

SNMP security mode

Determine the SNMPv3 security configuration.

MIB-based security management uses standard SNMPv3 MIBs to configure the user-based security model and the view-based access control model. This approach provides flexibility, enabling network operators to customize views and security levels for various user types. MIB-based security management leverages the built-in security management capabilities of existing network managers.

Web-based security management allows operators to configure users, security levels, privacy and authentication protocols, and passphrases using the 450 Platform Family web-based management interface. The capabilities are somewhat less flexible than those offered by MIB-based security management but are sufficient for many applications. Opting for web-based management for SNMPv3 security disables MIB-based security management. 450 Platform Family does not concurrently support MIB-based and web-based management of SNMPv3 security.

Web-based management of SNMPv3 security

Initial configuration of SNMPv3 security is available solely to HTTP or HTTPS user accounts with a security role of Security Officer.

Identify the format for SNMP Engine ID. The available formats include:

- MAC address (default)
- 5 and 32 hex characters (hex character input follows RFC 3411 recommendations on the Engine ID)

Specify the usernames and security roles of initial SNMPv3 users. Two security roles are available:

- Read Only
- System Administrator

Determine the security level for each security role. Three security levels are available:

- No authentication, no privacy
- Authentication, no privacy
- Authentication, privacy

If authentication is necessary, specify the protocol (available: MD5).

If privacy is used, specify the protocol (available: cbc-des).

Managing module access by passwords

By default, each module comes with a preconfigured administrator-level account named "root," which initially does not require an associated password. When you perform a module upgrade:

- An account named **admin** is created.
- Both **admin** and **root** inherit the password that was previously used to access the module, depending on the following conditions:
 - If a Full Access password was set, both **admin** and **root** inherit it.
 - If a Display-Only Access password was set and no Full Access password was set, both **admin** and **root** inherit the Display-Only Access password.



Caution

When using Wireless Manager, avoid deleting the root account from any module. Similarly, if your NMS communicates with modules via SNMP, exercise caution when considering the deletion of the root account from any module. Ensure you can confirm that the NMS does not depend on the root account for accessing the modules before proceeding.

Each module supports a maximum of four user accounts, regardless of the account levels. The available account levels are:

1. **ADMINISTRATOR**: This level grants full read and write permissions. It applies to the **root** and **admin** users, as well as any other administrator accounts created by them.
2. **INSTALLER**: Similar to **ADMINISTRATOR**, the **INSTALLER** level has identical permissions but cannot add or delete users or change the passwords of other users.
3. **TECHNICIAN**: This level allows modifications to basic radio parameters and access to informational web pages.
4. **GUEST**: **GUEST** users have no write permissions and can only access a limited view of the General Status tab.

Administrative, Installer, and Technician accounts can be configured as READ-ONLY, restricting their access to viewing only. The ability to view information on the General Status tab can be controlled using the **Site Information Viewable to Guest Users** option under the SNMP tab.

To enhance security from the factory default state, configure passwords for both the **root** and **admin** accounts at the **ADMINISTRATOR** permission level using the **Account > Change Users Password** page. If you choose to configure only one of them, be aware that the other account still have no password for access, posing a security risk. If you intend to configure only one, it is advisable to delete the **admin** account. Note that the **root** account is the sole account used by CNUT for updating the module. After setting a password for any **ADMINISTRATOR**-level account, initial access to the module GUI opens the view of the **GUEST** level.

Planning for RADIUS operation

Configure RADIUS when remote authentication is necessary for users accessing the web-based interface. Remote authentication offers several advantages:

- Centralized control of passwords.
- Enhanced management of user accounts, such as enforcing password changes at regular intervals and checking for password security.
- Password updates without the need to reconfigure multiple network elements.
- The ability to disable user accounts without reconfiguring multiple network elements.

However, remote authentication presents a notable drawback in wireless link products like the PMP 450 Platform Family. If the wireless link experiences an outage, a unit on the remote side of the broken link may be unable to contact a RADIUS Server, resulting in users losing access to the web-based interface.

A recommended strategy is to combine RADIUS authentication for regular operations with a single locally-authenticated user account for emergency situations.

The PMP 450 Platform Family SM supports a range of authentication methods, including:

- Phase 1:
 - EAP-MSCHAPv2
 - EAP-TTLS
 - EAP PEAP
- Phase 2:
 - PAP
 - CHAP
 - MSCHAPv2

Ensure that the selected authentication method in the PMP 450 Platform Family is compatible with the RADIUS server in use.

Filtering protocols and ports

Configure filters for specified protocols and ports from leaving the AP/BHM and SM/BHS and entering the network. This protects the network from both intended and inadvertent packet loading or probing by network users. By keeping the specified protocols or ports off the network, this feature also provides a level of protection to users from each other.

Protocol and port filtering is set per AP/SM/BH. Except for filtering of SNMP ports, filtering occurs as packets leave the AP/SM/BH.

For example, if SM is configured to filter SNMP, then SNMP packets are blocked from entering the SM and, thereby, from interacting with the SNMP portion of the protocol stack on the SM.

Port filtering with NAT Enabled

When NAT is enabled on the SM/BHS, port filtering can be applied to user-defined ports. Here are examples of situations where port filtering can be configured with NAT enabled:

- To prevent a subscriber from using FTP, you can filter Ports 20 and 21 (FTP ports) for both the TCP and UDP protocols.
- To restrict a subscriber's access to SNMP, you can filter Ports 161 and 162 (SNMP ports) for both the TCP and UDP protocols.



Note

In only the SNMP case, filtering occurs before the packet interacts with the protocol stack.

Protocol and Port Filtering with NAT Disabled

With NAT disabled on the SM/BHS, filtering can be applied to both protocols and three user-defined ports. This can be configured using the interface check boxes in either of the following ways:

- Allow all protocols except those that user wish to block.
- Block all protocols except those that user wish to allow.

Allow or block any of the following protocols:

- PPPoE (Point to Point Protocol over Ethernet)
- Any or all the following IPv4 (Internet Protocol version 4) protocols:
 - SMB (Network Neighborhood)
 - SNMP
 - Bootp Client
 - Bootp Server
 - Up to 3 user-defined ports
 - All other IPv4 traffic
- Any or all of the following IPv6 (Internet Protocol version 6) protocols:
 - Bootp Client
 - Bootp Server
 - Up to 3 user-defined ports
 - All other IPv6 traffic

SMB (Network Neighborhood)

SNMP

- Filter Direction – Upstream and Downstream
- ARP (Address Resolution Protocol)

Figure 92: Categorical protocol filtering

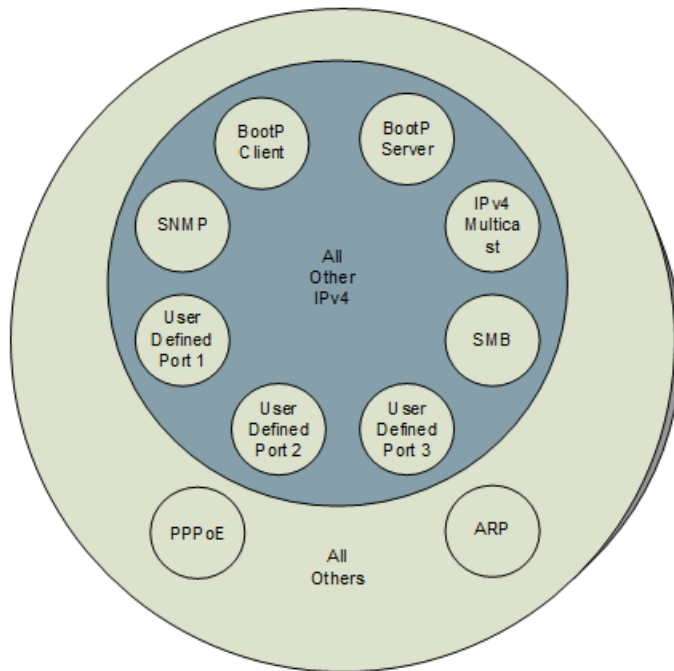

Here are example situations where protocol filtering is configured when NAT is disabled:

1. If you block a subscriber from using only PPPoE and SNMP, the subscribers still have access to all other protocols and all ports.
2. Suppose you block PPPoE, IPv4, and Uplink Broadcast while selecting the **All others** option. In this case, only the Address Resolution Protocol (ARP) is not filtered.

The ports that are filtered due to protocol selections in the Protocol Filtering tab of the SM/BHS are listed in [Table 129](#)..

Table 129: Ports filtered per protocol selections

Protocol Selected	Port Filtered (Blocked)
SMB	Destination Ports UDP: 137, 138, 139, 445, 3702 and 1900 Destination Ports TCP: 137, 138, 139, 445, 2869, 5357 and 5358
SNMP	Destination Ports TCP and UDP: 161 and 162
Bootp Client	Source Port 68 UDP
Bootp Server	Source Port 67 UDP
User Defined Port 1.3	User defined ports for filtering UDP and TCP
IPv4 Multicast	Block IPv4 packet types except other filters defined

Protocol Selected	Port Filtered (Blocked)
IPv6 Multicast	Block IPv6 packet types except other filters defined
ARP	Filter all Ethernet packet type 806
Upstream	Applies packet filtering to traffic coming into the FEC interface
Downstream	Applies packet filtering to traffic destined to exit the FEC interface

Port Configuration

The 450 Platform Family provides support for various communication protocols, and only the ports necessary for these protocols are accessible to external entities. Operators have the flexibility to modify the port numbers associated with these protocols through either the radio GUI or SNMP.

Table 130: Device default port numbers

Port	Usage	Port Usage	Device
21	FTP	Listen Port	AP, SM
80	HTTP	Listen Port	AP, SM
443	HTTPS	Listen Port	AP, SM
161	SNMP port	Listen Port	AP, SM
162	SNMP trap port	Destination Port	AP, SM
514	Syslog Server port	Destination Port	AP, SM
1812	Standard RADIUS port	Destination Port	AP
1813	Standard RADIUS accounting port	Destination Port	AP, SM

Encrypting downlink broadcasts

An AP can be enabled to encrypt downlink broadcast packets such as the following:

- ARP
- NetBIOS
- broadcast packets containing video data on UDP.

The encryption used is AES for an AES-configured module. Before the Encrypt Downlink Broadcast feature is enabled on the AP, air link security must be enabled on the AP.

Isolating SMs in PMP

Within an AP, it is possible to restrict direct communication between SMs in the sector. Similarly, in CMM4/CMM5, connected APs can be isolated from direct communication with each other, effectively preventing SMs in different sectors of a cluster from inter-SM communication.

To configure the SM Isolation feature in the AP, navigate to the General tab of the **Configuration** web page and select one of the following options from the drop-down menu:

1. Disable SM Isolation (the default selection): This permits full communication between SMs.
2. Enable Option 1 - Block SM destined packets from being forwarded: This prevents both multicast/broadcast and unicast SM-to-SM communication.
3. Enable Option 2 - Forward SM destined packets upstream: This not only inhibits multicast/broadcast and unicast SM-to-SM communication but also directs these packets, which might otherwise have been routed SM to SM, through the Ethernet port of the AP.

In the CMM and CMM4/CMM5, the treatment of SM isolation results from managing the port-based VLAN feature of the embedded switch. This feature allows all traffic to be routed from any AP to a designated uplink port. However, it's important to note that this is not packet-level switching and is not dependent on VLAN IDs.

Filtering management through Ethernet

Configure the SM to prohibit any device connected to its Ethernet port from reaching the SMs IP address. If the Ethernet Access Control parameter is set to Enabled, the following conditions apply:

1. No requests to access the SM management interface (via http, SNMP, ftp, or tftp) through Ethernet are permitted.
2. Any attempts to access the SM management interface over the air (using the SM's IP address, assuming LAN1 Network Interface Configuration, Network Accessibility is set to Public, or through links from the Session Status or Remote Subscribers tab in the AP) remain unaffected.

Allowing management from only specified IP addresses

In the Security sub-menu of the Configuration web page on the AP/BHM and SM/BHS, you can find the IP Access Control parameter. Here, you can specify one, two, or three IP addresses that are permitted to access the management interface (via HTTP, SNMP, FTP, or TFTP).

- If IP Access Filtering is Disabled, management access is granted from any IP address, regardless of the content of the Allowed Source IP 1 to 3 parameters.
- If IP Access Filtering is Enabled, and you specify at least one address in the Allowed Source IP 1 to 3 parameter, management access is restricted to the specified address(es).

Configuring management IP by DHCP

Within the **Configuration > IP web page** of each radio, there is a LAN1 Network Interface Configuration option known as DHCP State. When this option is enabled, it allows the automatic acquisition of IP configuration details such as IP address, subnet mask, and gateway IP address through DHCP. This eliminates the need for manual configuration of these parameters. The status of the DHCP state parameter can also be viewed (though not modified) within the Network Interface tab of the Home page.

In the case of the SM/BHS, adjustments to this parameter can be made in the following ways:

- In the NAT tab of the Configuration web page, if NAT is enabled.
- In the IP tab of the Configuration web page, but only when the Network Accessibility parameter in the IP tab is set to Public.

DHCP option 81

DHCP Option 81 allows DHCP-enabled clients to register and update DNS resource records (PTR and A records) through the DHCP server. This option allows clients to provide their fully qualified domain name (FQDN) and specify how the DHCP server must handle DNS dynamic updates on their behalf. The hostname is constructed as SiteName.DomainName under the following conditions:

- If SiteName is not provided (default), the MAC address is used instead.
- The SiteName can only contain alphanumeric characters (a-z, A-Z, 0-9), periods (.), and dashes (-).
- The domain name part must not begin or end with a dash (-).
- Underscores or spaces in the domain name part are replaced with dashes (-), while any other invalid characters are omitted.

Controlling PPPoE PADI Downlink Forwarding

You can control the forwarding of PPPoE PADI (PPPoE Active Discovery Initiation) packets on the AP. This feature is configured in the AP GUI **Configuration > Radio** page using the **PPPoE PADI Downlink Forwarding** parameter.

When this parameter is set to **Enabled** the AP permits both downstream and upstream transmission of PPPoE PADI packets. However, if it's set to **Disabled**, the AP prohibits the forwarding of PPPoE PADI packets through the AP's RF interface in the downstream direction. Still, it allows these packets to enter the RF interface (upstream) and exit through the Ethernet interface.

Remote AP deployment

In scenarios where the subscriber population is widely dispersed, or geographical constraints limit network expansion, incorporating a Remote AP can prove advantageous:

- Deliver high-throughput service to near LoS business subscribers: The Remote AP extends high-throughput services to business subscribers in proximity with a LoS connection.
- Bypass obstructions and foliage for non-LoS throughput: It enables network connectivity by circumventing obstructions and penetrating foliage, ensuring non-LoS throughput.
- Extend broadband service to new, especially widely distributed, residential subscribers: By deploying remote APs, you can provide broadband services to new and widely dispersed residential subscribers.
- Facilitate sync transmission for an additional RF Hop: Remote APs can pass synchronization signals for an additional radio frequency hop.

In the remote AP configuration, a remote AP is co-located with an SM. The remote AP distributes the signal to SMs that are logically behind the co-located SM. A remote AP deployment is illustrated in [Figure 93](#).

Figure 93: Remote AP deployment

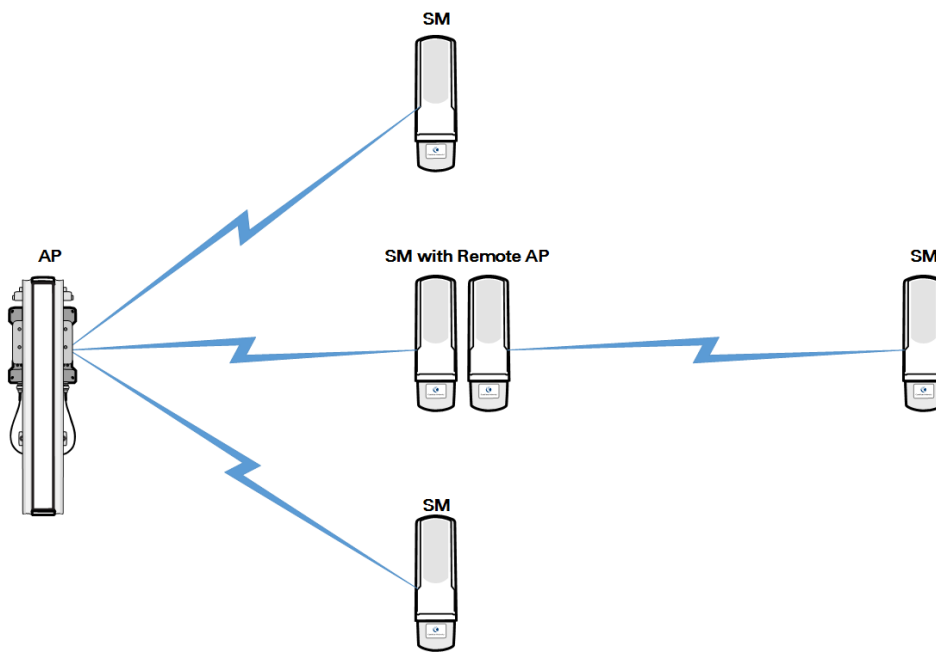

The co-located SM receives data in one channel, and the remote AP must redistribute the data in a different channel. The two channels need to have a frequency gap equal to at least two times the used channel bandwidth.

Base your selection of frequency band ranges on regulatory restrictions, environmental conditions, and throughput requirements.



Note

Each relay hop (additional daisy-chained remote AP) adds approximately 5-7 msec round trip latency.

Remote AP (RAP) Performance

The performance of a Remote AP (RAP) matches that of an AP within a cluster, including equivalent throughputs, ranges, and antenna coverage. However, it's important to note that when working in the unlicensed spectrum, conducting site surveys before adding network elements is highly recommended. These surveys help determine the availability of spectrum in the desired expansion area. Keep in mind the following considerations:

1. Non-LoS ranges are significantly affected by environmental conditions.
2. In many regions, not all frequencies may be accessible.
3. Ensure that your deployments align with local regulatory restrictions.

Example use case for RF obstructions

A remote AP can effectively serve as a solution to provide last-mile access to a community when RF obstructions hinder SMs from establishing direct communication with the higher-level AP within the cluster. For instance, consider a scenario where the utilization of 900 MHz frequencies resolves connectivity challenges between a remote AP and distant SMs that struggle to establish robust links with a higher-level 5 GHz AP. In such cases, the 900-MHz wavelength demonstrates its effectiveness in overcoming obstructions, particularly in environments with dense foliage over short distances, effectively addressing the issue of foliage penetration.

An example of this use case is shown in [Figure 94](#)

- The 5 GHz AP operates as a PMP 450i AP in the 5.8 GHz band, utilizing a 20 MHz channel with a 2.5 ms frame.
- The SMs utilized are 5 GHz PMP 450 integrated SMs.
- The SM connected to the remote AP functions as a PMP 450i SM.
- The remote AP operates as a PMP 450i AP in the 900 MHz band, also utilizing a 20 MHz channel with a 2.5 ms frame.
- The SMs employed are 900 MHz PMP 450 connectorized SMs, equipped with the Cambium 23 dBi gain antenna.

Figure 94: Example for 900-MHz remote AP behind 5 GHz SM

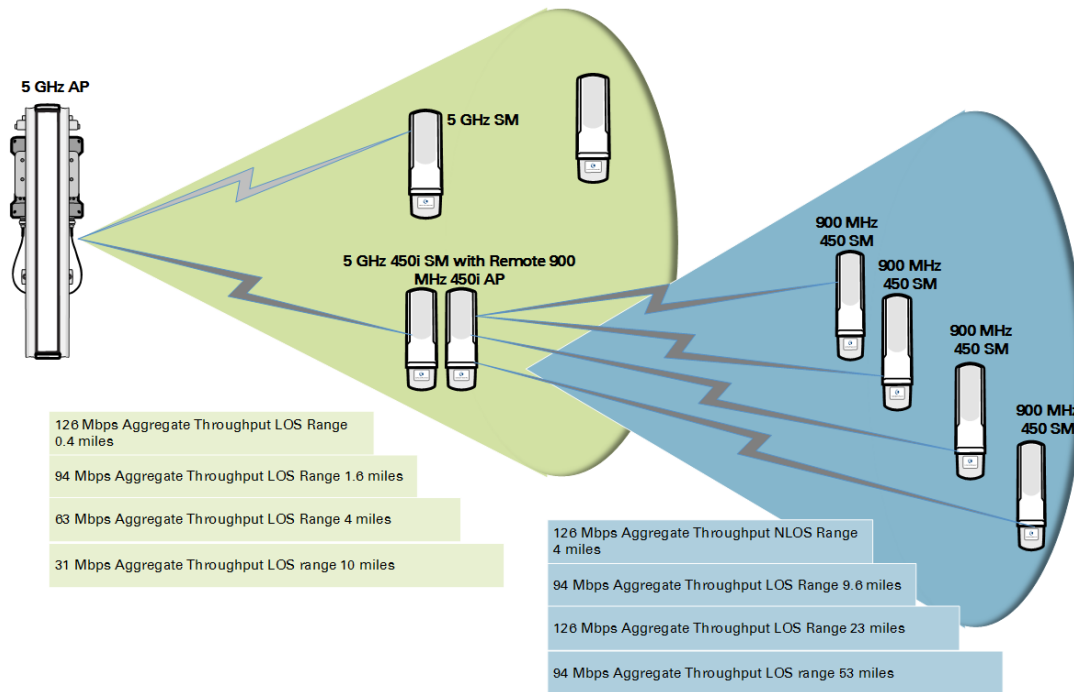

The 5 GHz modules provide a sustained aggregate throughput of up to 126 Mbps to the sector. One of the SMs in the sector is wired to a 900-MHz remote AP, which provides NLoS sustained aggregate throughput¹ of:

- 126 Mbps to 900-MHz SMs up to 4 miles away in the sector.
- 94 Mbps to 900-MHz SMs between 4 and 10 miles away in the sector.

Example use case for passing sync

All radios within the network infrastructure support the remote AP functionality. Both the BHS and SM devices are equipped to reliably transmit the sync pulse, and the BHM and AP devices are designed to effectively receive it.

However, it is essential to note that not all devices are universally compatible with one another. The following table provides a reference to identify the compatibility of specific SMs with their corresponding APs.

Table 131: Passing Sync in an Additional Hop

Devices	PMP 450 AP/BHM	PMP 450i AP/BHM	PMP 450m AP
PMP 450 SM/BHS	X		
PMP 450i SM/BHS		X	X

¹

Examples of passing sync over cable are shown in [Table 131](#).

- For the PMP 450 series, synchronization is achieved by connecting Pins 1 and 6 of the RJ-11 timing ports on the two modules using a cable.
- In the case of the PMP 450i/450m series, synchronization is accomplished by utilizing a cable to connect Pins 7 and 8 of the RJ-45 timing ports on both modules.
- When establishing these connections between modules, it is imperative to ensure that the AP and SM are properly configured, as described in the section titled **Wiring to Extend Network Sync**.

Physical connections involving the remote AP

The SM to which a remote AP is connected to can be either an SM that serves a customer or an SM that simply serves as a relay. If the SM serves a customer, wire the remote AP to the SM as shown in [Figure 95](#).

[Figure 95](#): Remote AP wired to SM that also serves a customer

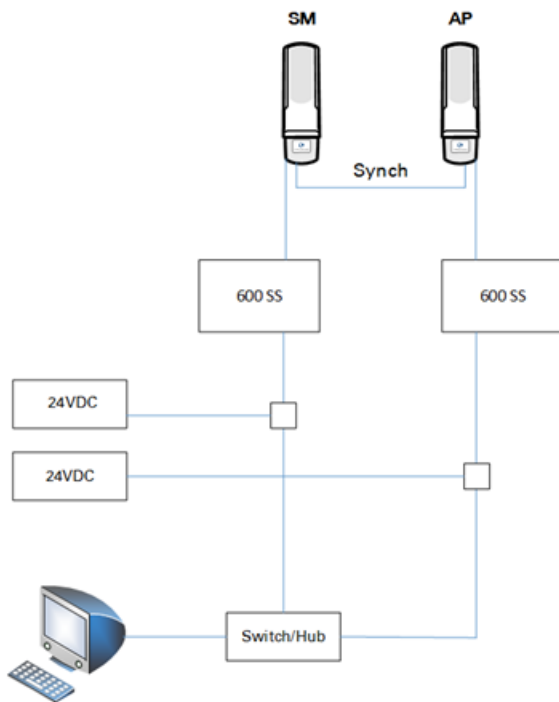

If the SM simply serves as a relay, you must use a straight-through RJ-45 female-to-female coupler and wire the SM to the remote AP as shown in [Chapter 3](#).

Figure 96: Remote AP wired to SM that serves as a relay

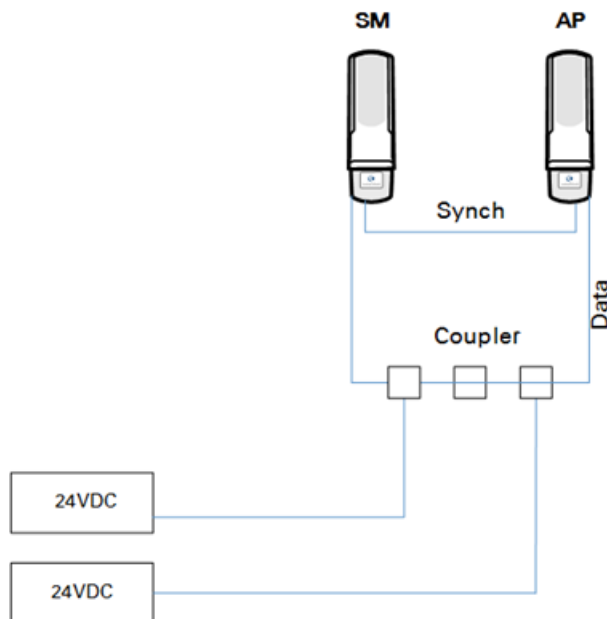

Passing Sync signal

Passing sync in a single hop

Network sync can be passed in a single hop in the following network designs:

- Design 1
 - A CMM provides sync to a co-located AP.
 - This AP sends the sync over the air to SMs.
- Design 2
 - A CMM provides sync to a co-located BH timing master.
 - This BH timing master sends the sync over the air to a BH timing slave.

Passing sync in an additional hop

Network sync can be extended by one additional link in any of the following network designs:



Note

In each of these following designs, Link 2 is not on the same frequency band as Link 4. (For example, Link 2 may be a 5.2 GHz link while Link 4 is a 5.7 or 2.4 GHz link.)

- Design 3
 - A CMM provides sync to a co-located AP.
 - This AP sends the sync over the air to an SM.
 - This SM delivers the sync to a co-located AP.
 - This AP passes the sync in the additional link over the air to SMs.

This design is illustrated in [Figure 97](#).

[Figure 97](#): Additional link to extend network sync, Design 3

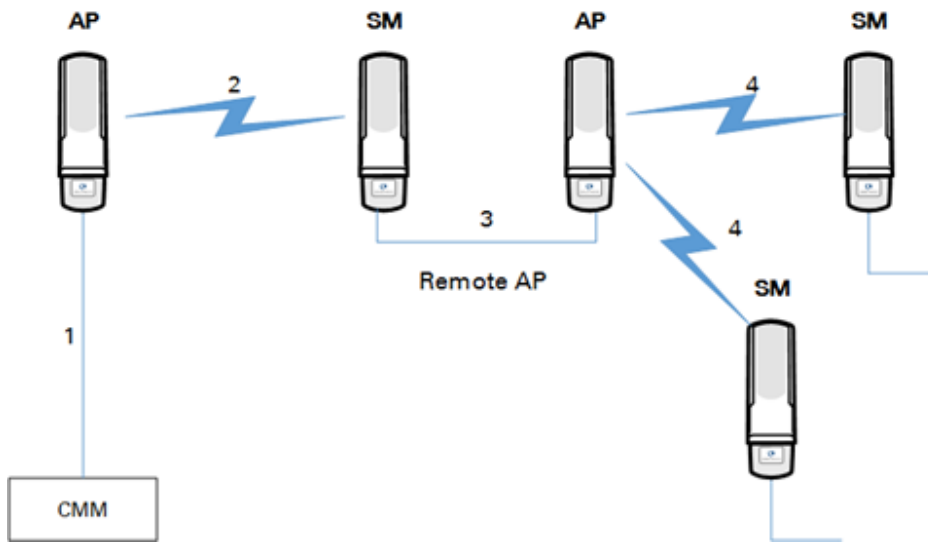

- Design 4
 - A CMM provides sync to a co-located AP.
 - This AP sends the sync over the air to an SM.
 - This SM delivers the sync to a co-located BHM.
 - This BHM passes the sync in the additional link over the air to a BHS.

This design is illustrated in [Figure 98](#).

Figure 98: Additional link to extend network sync, Design 4

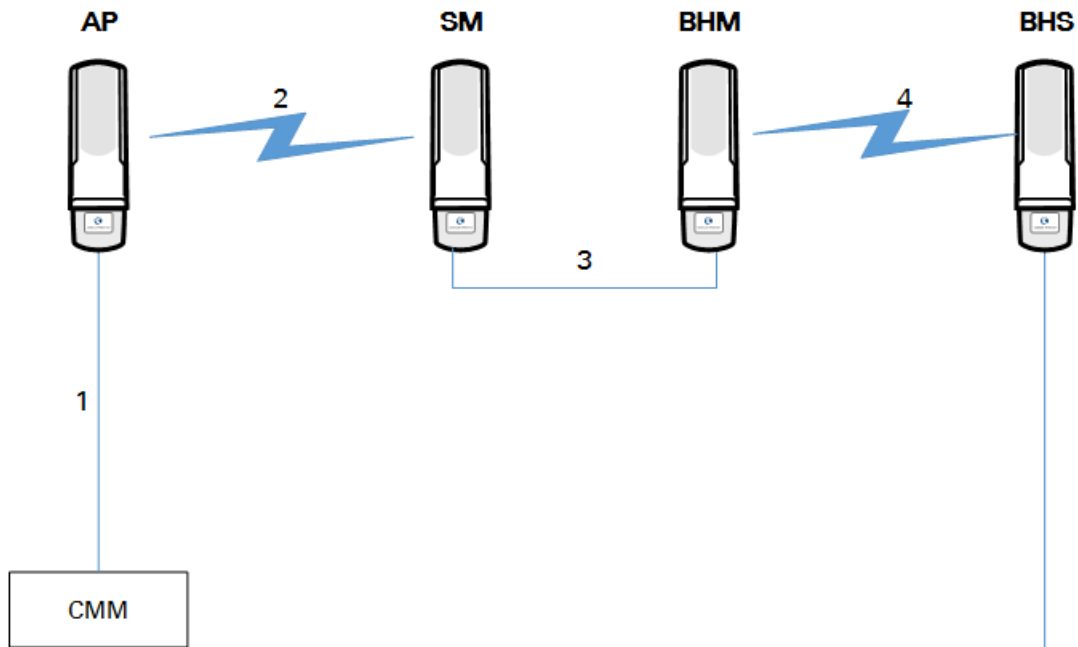

- **Design 5**

- A CMM provides sync to a co-located BHM or the BHM generates timing.
- This BHM sends the sync over the air to a BHS.
- This BHS delivers the sync to a co-located AP.

This AP passes the sync in the additional link over the air to SMs.

This design is illustrated in [Figure 99](#).

Figure 99: Additional link to extend network sync, Design 5

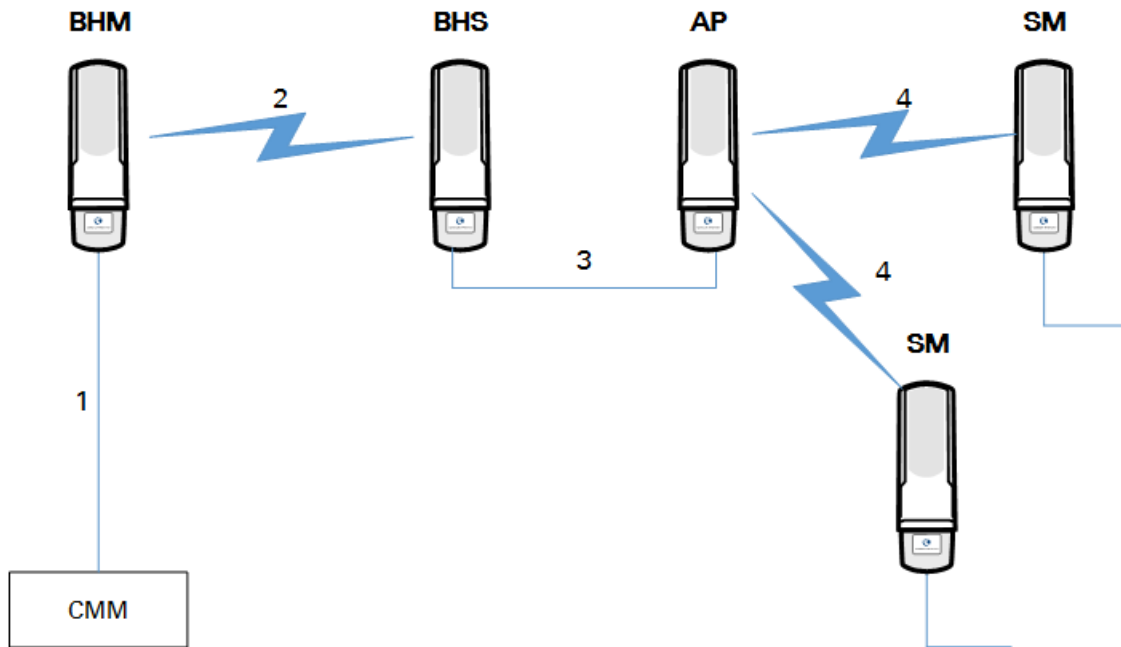

Wiring and configuration information for this sync extension is described under [Wiring to extend network sync](#).

Wiring to extend network sync

The following procedure can be used to extend network sync by one additional hop, as described under [Passing sync in an additional hop](#). When a co-located module receives sync over the air, the co-located modules can be wired to pass the sync as follows:

1. Connect the GPS Utility ports of the co-located modules using a sync cable with RJ-11 (for 450) or RJ-45 (for 450i/450m) connectors.
2. Set the Sync Input parameter on the Configuration page of the co-located AP or BH timing master to AutoSync.
3. Set the Device Type parameter on the Configuration page of the co-located AP or BH timing master to Remote.
4. Set the Sync Output to Aux Port parameter on the Configuration page of the co-located AP or BH timing master to Disabled.
5. Set the UGPS Power parameter on the Configuration page of the co-located AP or BH timing master to Disabled.
6. Set the Frame Timing Pulse Gated parameter on the Configuration page of the co-located SM or BH timing slave to Enable.



Note
This setting prevents interference if the SM or BH timing slave loses sync.

Figure 100: Co-located AP or BH timing master Sync Setting configuration

Sync Setting	
Sync Input :	AutoSync ▾
Free Run Before GPS Sync :	<input type="radio"/> Enabled <input checked="" type="radio"/> Disabled
Device Type :	<input type="radio"/> Standard <input checked="" type="radio"/> Remote
Verify GPS Message Checksum :	<input checked="" type="radio"/> Enabled <input type="radio"/> Disabled
Sync Output to Aux Port :	<input type="radio"/> Enabled <input checked="" type="radio"/> Disabled
UGPS Power :	<input type="radio"/> Enabled <input checked="" type="radio"/> Disabled



Caution
Intentional or unintentional changes or modifications to the equipment must not be made unless under the express consent of the party responsible for compliance. Any such modifications could void the user's authority to operate the equipment and void the manufacturer's warranty.

Chapter 4: Preparing for installation

This chapter describes how to stage and test the hardware for a 450 Platform family series. The chapter covers the following topics:

- [Safety](#)
- [Preparing for installation](#)
- [Testing system components](#)
- [Configuring Link for Test](#)

Safety

Hazardous locations



Warning

When installing the PMP/PTP 450i ATEX/HAZLOC product variants in hazardous locations, follow the instructions contained in the PMP/PTP 450i Series Hazardous Location Guide (supplied in box with the products), in addition to the instructions in this user guide.

Siting of ODU and soundness of structure

- Ensure that the Outdoor Unit (ODU) and the structure to which it is mounted can withstand the maximum wind speeds at a proposed site.
- See windloading guidance in [ODU wind loading](#).

Working at heights and near power lines

- Exercise extreme care when working at heights.
- Observe national 'working at heights' regulations. Use trained competent staff.
- Exercise extreme care when working near power lines.

Power supply and power safety

- Always use a Cambium specified 450 Platform Family power supply unit (PSU) to power the ODU. Failure to use a Cambium supplied PoE could result in equipment damage and may cause a safety hazard.

- Ensure the equipment is not powered during installation.
- Always power down and disconnect the equipment from its power source before servicing.
- The ODU power supply is the primary disconnect device.

External cables

- Use outdoor rated cables for connections that will be exposed to the outdoor environment.
- Install Cambium recommended cables.
- Safety may be compromised if outdoor rated cables are not used for connections that will be exposed to the outdoor environment.
- For outdoor copper Cat5e Ethernet interfaces, always use Cat5e cable that is gel-filled and shielded with copper-plated steel.

RF exposure near the antenna

Harmful levels of RF radiation are present close to the antenna when the transmitter is on.

- Observe the minimum safe distance limit for 450 products, see the Product leaflet or Configuration guide
- Ensure that equipment is installed in a position avoiding any radiation hazard to humans.
- Always turn off the power to the ODU before undertaking maintenance activities in front of the antenna.
- The units start to radiate RF energy as soon as they are powered up.

Grounding and lightning protection requirements

Structures, equipment and people must be protected against electrostatic discharge: -

- By siting ODU equipment in a lightning protection zone
 - ODUs, external antennas and GPS receivers are not designed to survive direct lightning strikes. For this reason they must be installed in Zone B as defined in [Lightning protection zones](#).
 - Mounting in Zone A may put equipment, structures and life at risk.
- By installation of appropriate lightning conductors to conduct the surge current to ground via a separate preferential solid path.
- Ground bonding and transient voltage surge suppression is recommended. Use Cambium specified surge suppressors.

- Grounding conductor runs are as short, straight and smooth as possible, with bends and curves kept to a minimum.
 - All bends must have a minimum radius of 200 mm (8 in) and a minimum angle of 90°. A diagonal run is preferable to a bend, even though it does not follow the contour or run parallel to the supporting structure.
 - All bends, curves and connections must be routed towards the grounding electrode system, ground rod, or ground bar.
- Grounding cables must not be installed with drip loops.
- Grounding conductors must be securely fastened.
- Braided grounding conductors must not be used.
- Approved bonding techniques must be used for the connection of dissimilar metals.

Ensure that the installation meets the requirements defined in [Grounding and lightning protection](#) on page 1.

Grounding and protective earth

The Outdoor Unit (ODU) must be properly grounded to protect against lightning. It is the user's responsibility to install the equipment in accordance with national regulations. In the USA follow the requirements of the National Electrical code NFPA 70-2005 and 780-2004 Installation of Lightning Protection Systems. In Canada, follow Section 54 of the Canadian Electrical Code. These codes describe correct installation procedures for grounding the outdoor unit, mast, lead-in wire and discharge unit, size of grounding conductors and connection requirements for grounding electrodes. Other regulations may apply in different countries and therefore it is recommended that installation of the outdoor unit be contracted to a professional installer.

Thermal Safety

The ODU enclosure may be hot to the touch when in operation. The ODU must not be operated in ambient temperatures exceeding 40°C unless mounted in a Restricted Access Location. For more information, see [ODU ambient temperature limits](#).



Warning

Do not install the ODU in a location where the ambient temperature could exceed 40°C unless this is a Restricted Access Location as defined by EN 60950-1.



Warning

L'unité externe ne doit pas être installée dans un endroit où la température ambiante est supérieure à 40C à moins que l'accès soit limité au personnel autorisé.

Preparing for installation

ODU pre-configuration

It is common practice to pre-configure the units during staging before site installation by performing the following tasks as explained in *Configuration Guide*.

- Connecting to the unit
- Configuring IP and Ethernet interfaces
- Upgrading the software version and using CNUT
- General configuration
- Configuring security
- Configuring radio parameters
- Setting up SNMP agent
- Configuring syslog
- Configuring remote access
- Monitoring the Link
- Configuring quality of service
- Zero Touch Configuration Using DHCP Option 66
- Configuring Radio via config file
- Configuring a RADIUS server

If the units are to be pre-configured during staging, the safety precautions below **MUST** be observed.

Preparing personnel

In no event shall Cambium Networks be liable for any injury or damage caused during the installation of the Cambium 450 Platform Family ODU.

Ensure that only qualified personnel undertake the installation of a 450 Platform system.

Ensure that all safety precautions are observed.

Preparing inventory

Perform the following inventory checks:

- Check that the correct components are available, as described in [Ordering the components](#).
- Check the contents of all packages against their packing lists.

Preparing tools

Check that following specific tools are available, in addition to general tools:

- RJ45 crimp tool (it must be the correct tool for the type of RJ45 being used).
- Personal Computer (PC) with 10 or 100 or 1000 BaseT Ethernet port
- Web browser
- Ethernet patch cables

Testing system components

The best practice is to connect all components—AP/BHM, SMs/BHS, GPS antenna (if applicable) and CMM (if applicable)—in a test setting and initially configure and verify them before deploying them to an installation. In this way, any configuration issues are worked out before going on-site, on a tower, in the weather, where the discovery of configuration issues or marginal hardware is more problematic and work-flow affecting.

Unpacking Components

When a delivery arrives, inspect all packages immediately for damages.

Carefully unpack the equipment, verify that all the components have arrived as per order and are in good condition. Save all packaging materials for equipment transportation to the installation site.

Preparing the ODU

After the equipment is unpacked, the units may be configured for staging tests.

Use either of two methods to configure an AP/BHM:

- Use the Quick Start feature of the product (via GUI menu Quick Start)
- Manually set each parameter

After changing configuration parameters on a GUI web page:

- Before you leave a web page, click the Save button to save the change(s)
- After making change(s) on multiple web pages, click the Reboot button to reboot the module and implement the change(s)

Configuring the Computing Device for Test

If the computer is configured for Dynamic Host Configuration Protocol (DHCP), disconnect the computer from the network. If the computer is instead configured for static IP addressing

- Set the static address in the 169.254 network
- Set the subnet mask to 255.255.0.0.

For detailed instructions, see section [Configuring the management PC](#) on page [Configuring the management PC](#).

Factory default Configuration

From the factory, the APs/BHMs and SMs/BHSs are all configured to not transmit on any frequency. This configuration ensures that equipment operators do not accidentally turn on an unsynchronized module. Site synchronization of modules is required because

- Modules:
 - cannot transmit and receive signals at the same time.
 - use TDD (Time Division Duplexing) to distribute signal access of the downlink and uplink frames.
- When one module transmits while an unintended module nearby receives signal, the transmitting module may interfere with or desense the receiving module. In this context, interference is self-interference (within the same network).

ODU interfaces

See section [450 Platform Family interfaces](#).

ODU diagnostic LEDs

See section [AP/BHM LEDs](#).

Table 132: [5/6 GHz 450b BHM LED descriptions](#)

LED	Color when active	Status information provided	Notes
POWER	Blue	DC power	Always lit after 10-20 seconds of power on.
SYNC	Green	Presence of sync	-
SES	Yellow	Unused	-

LED	Color when active	Status information provided	Notes
GPS	Red	Pulse of sync	Lit when the BHM is getting a sync pulse from a GPS source goes along with SYNC.
ETH	Red/Green/Orange (multi-colored for 10/100/1000).	Presence of data activity on the Ethernet link	Lit when link is present: 10BASE-T = Red 100BASE-T = Green 1000BASE-T = Orange Flashes during data transfer. Frequency of flash is not a diagnostic indication.

Table 133: 3 GHz 450b BHM LED descriptions

LED	Color when active	Status information provided	Note
POWER	Blue	DC power	Always lit after power on
ETH	Red / Green / Orange	Flashes in presence of data activity on the Ethernet link	10BASE-T = Red 100BASE-T = Green 1000BASE-T = Orange
SES/ SYN	Yellow / Green	Sync status: - Generating sync = Yellow Receiving sync = Green Solid = Unit transmitting Blinking = Unit synchronized, but not transmitting	-

Recommended tools for installation

The following tools may be needed for installation:

Table 134: Tools for PMP and PTP 450 Platform ODU installation

Equipment to Be Installed	Tools Required
AP or BHM	<ul style="list-style-type: none"> • 3 mm Allen Wrench <p>Used for connecting the antenna mating bracket to the rear of the AP housing</p> <ul style="list-style-type: none"> • Crescent Wrench Pair <p>Used for tightening cable glands</p> <ul style="list-style-type: none"> • Self-amalgamating and PVC Tape <p>Used for weatherproofing N-type connections</p>

Equipment to Be Installed	Tools Required
AP or BHM or BHS Antenna	<ul style="list-style-type: none"> • 13 mm Spanner Wrench (or Ratchet Spanner Wrench) Pair <p>Used for connecting the antenna (sector or omni for AP, or directional for BH) base to the pole/mast mounting bracket</p> <ul style="list-style-type: none"> • Self-amalgamating and PVC Tape <p>Used for weatherproofing N-type connections</p> <ul style="list-style-type: none"> • N-type Torque Wrench (not required but recommended) <p>Used for assuring proper tightening of N-type connectors terminating the RF cables</p>
SM	<ul style="list-style-type: none"> • Wrench/driver (depending on operator's choice of clamps) <p>Used for tightening clamps to the pole</p> <ul style="list-style-type: none"> • Alignment tone adapter / headset <p>Used for aligning the SM to the AP</p>
Universal Global Positioning System	<ul style="list-style-type: none"> • Philips Screwdriver <p>Used for attaching the UGPS unit to the pole/mast mounting bracket</p> <ul style="list-style-type: none"> • 13mm Spanner Wrench (or Ratchet Spanner Wrench) <p>Used for connecting the mounting bracket's U-bolt to the antenna or mast</p>
Cabling	<ul style="list-style-type: none"> • Electrician's Scissors or Wire Cutters <p>Used for cutting wire to length</p> <ul style="list-style-type: none"> • RJ-11/RJ-45 Crimping Tool <p>Used for stripping RJ-11/RJ-45 cables and for terminating cable ends</p> <ul style="list-style-type: none"> • Cable Testing Device <p>Used to ensure that cables are properly constructed</p>

Standards for wiring

Modules automatically sense whether the Ethernet cable in a connection is wired as straight-through or crossover. Operators may use either straight-through or crossover cable to connect a network interface card (NIC), hub, router, or switch to these modules. This guide follows the EIA/TIA-568B colour code standard.

Best practices for cabling

The following practices are essential to the reliability and longevity of cabled connections:

- Use only shielded cables to resist interference.
- For vertical runs, provide cable support and strain relief.
- Include a 2-ft (0.6-m) service loop on each end of the cable to allow for thermal expansion and contraction and to facilitate terminating the cable again when needed.
- Include a drip loop to shed water so that most of the water does not reach the connector at the device.
- Properly crimp all connectors.
- Use dielectric grease on all connectors to resist corrosion.
- Use only shielded connectors to resist interference and corrosion.

Wiring connectors

The following diagrams correlate pins to wire colors and illustrate crossovers where applicable.

Pin 1, relative to the lock tab on the connector of a straight-through cable is located as shown below.

Figure 101: Pin 1 location

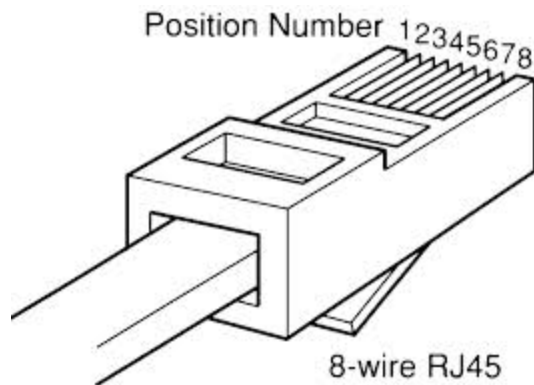

Main port pinout

Table 135: Main port pinout

RJ45 pin	Description
1	+TxRx0

RJ45 pin	Description
2	-TxRx0
3	+TxRx1
4	+TxRx2
5	-TxRx2
6	-TxRx1
7	+TxRx3
8	-TxRx3

Aux port pinout

Table 136: Aux port pinout

RJ45 pin	Description
1	+TxRx0
2	-TxRx0
3	+TxRx1
4	GPS power out, Alignment tone out, GPS data out
5	GPS data in
6	-TxRx1
7	GPS 0v
8	GPS Sync in

RJ-45 Pinout for straight-through Ethernet cable

Figure 102: Straight-through Ethernet Cable

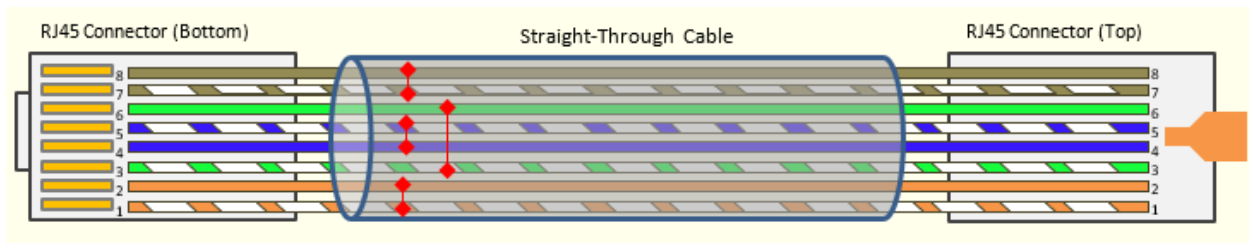

Table 137: RJ-45 pinout for straight-through Ethernet cable

Pin	Signal	Pair	Color
1	TP1+	2	White/orange stripe
2	TP1-	2	Orange solid
3	TP2+	3	White/green stripe
4	TP3+	1	Blue solid
5	TP3-	1	White/blue stripe
6	TP2-	3	Green solid
7	TP4+	4	White/brown stripe
8	TP4-	4	Brown solid

RJ-45 Pinout for crossover Ethernet cable

Figure 103: Crossover Ethernet Cable

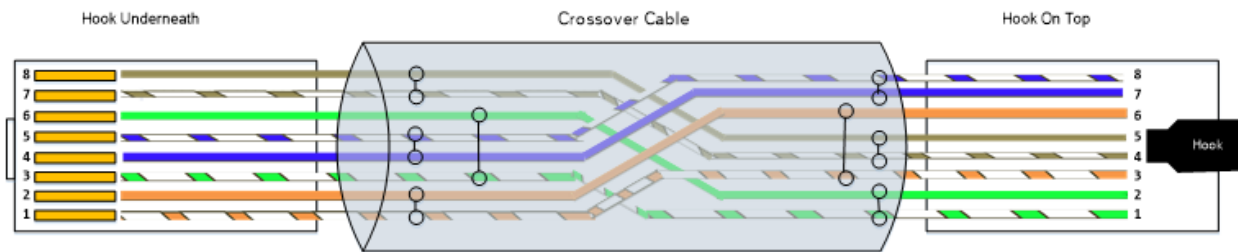

Table 138: RJ-45 pinout for crossover Ethernet cable

Pin	Connection 1			Connection 2		
	Signal	Pair	Color	Signal	Pair	Color
1	TP1+	2	White/orange stripe	TP2+	3	White/green stripe
2	TP1-	2	Orange solid	TP2-	3	Green solid
3	TP2+	3	White/green stripe	TP1+	2	White/orange stripe
4	TP3+	1	White/blue stripe	TP4+	4	White/brown stripe
5	TP3-	1	Blue solid	TP4-	4	Brown solid
6	TP2-	3	Green solid	TP1-	2	Orange solid
7	TP4+	4	White/brown stripe	TP3+	1	Blue solid
8	TP4-	4	Brown solid	TP3-	1	White/blue stripe

AP/BHM to UGPS cable

The AP/BHM to UGPS cable can be constructed from RJ12 to RJ 45 cable using the pin configuration described in [AP/BHM to UGPS cable pinout](#).



Note

This applies only to 450 AP/BHM.

The AP/BHM only powers up the UGPS if it is configured to do so.

Figure 104: AP/BHM to UGPS cable

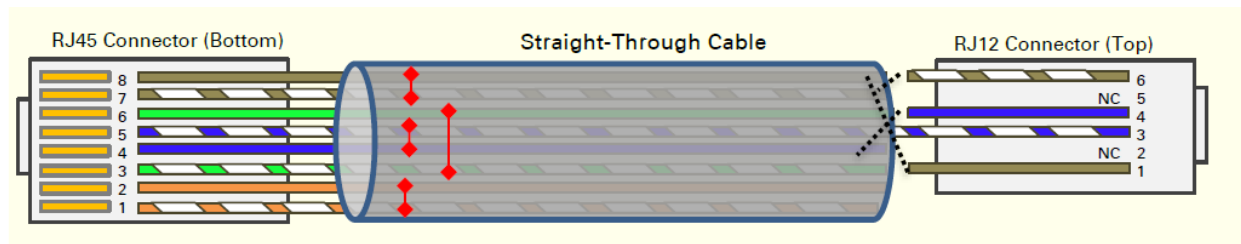

Table 139: AP/BHM to UGPS cable pinout

Pin	450i Series AP RJ 45 Connector	Pin	UGPS RJ 12 Connector	Connector
1	NC	1	8 on RJ 45	
2	NC	2	NC	
3	NC	3	5 on RJ 45	
4	4 on RJ 12	4	4 on RJ 45	
5	3 on RJ 12	5	NC	
6	NC	6	7 on RJ 45	
7	6 on RJ 12			
8	1 on RJ 12			

Alignment tone cable (for PMP/PTP 450i)

The alignment tone cable is constructed using RJ45 plug and Stereo plug. The pin configuration is shown in [Alignment tone cable pin configuration](#)

Figure 105: Alignment tone cable pin configuration

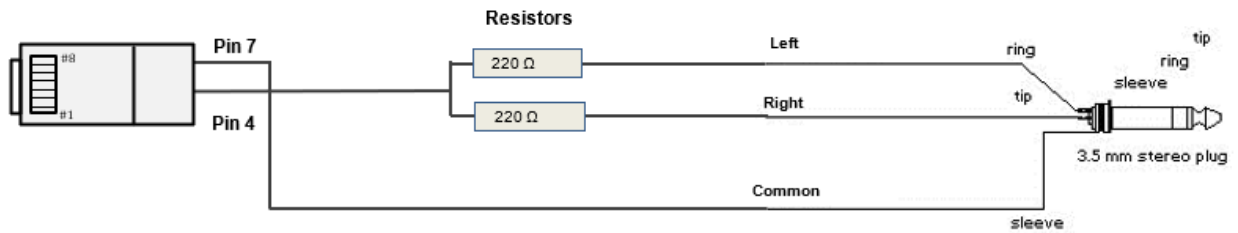

For more information, refer [Aux port to alignment tone headset wiring](#).

Override plug cable (for PMP 450 only)

To construct an override plug, perform the following steps:

- Crimp an RJ-12 6 pins connector onto a 6-inch length of CAT 5 cable
- Pin out all 6 pins
- Short (solder together) pins 4 and 6 on the other end. Do not connect any other wires to anything.

Figure 106: RJ-12 pinout for the default plug

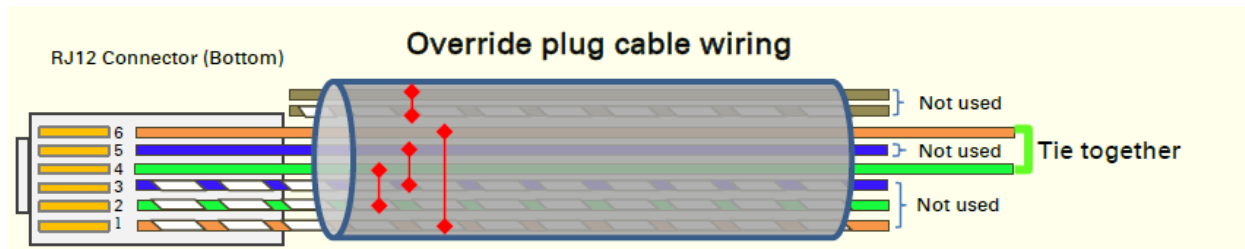

Configuring Link for Test

It is important to stage the AP/BHM and SM/BHS units first to verify proper registration before deploying the modules to the site. To begin configuring the modules for test, see the sections below:

Configuring the management PC

To configure the local management PC to communicate with the AP, SM, BHM or BHS, proceed as follows:

Powering the AP/SM/BH for test configuration

Perform the following steps to power on the ODU.

Procedure 2 Powering the ODU

1	Plug one end of a CAT 5 Ethernet cable into the ODU.
2	Plug the Ethernet cable connector labeled To Radio into the jack in the pig tail that hangs from the power supply.
3	Plug the other connector of the pig tail (this connector labeled To Computer) into the Ethernet jack of the computing device.
4	Plug the power supply into an electrical outlet.  Warning From this point until you remove power from the ODU, stay at least as far from the AP as the minimum separation distance specified.
5	Power up the computing device
6	Start the browser in the computing device

The AP/BHM interface provides a series of web pages to configure and monitor the unit. Access web-based interface through a computing device that is either directly connected or connected through a network to the AP/BHM. If the computing device is not connected to a network when it is being configured for test environment, and if the computer has used a proxy server address and port to configure a module, then the operator may need to first disable the proxy setting in the computer.

Perform the following procedure to toggle the computer to not use the proxy setting.

Procedure 3 Bypassing browser proxy settings to access module web pages

1	Launch Microsoft Internet Explorer
2	Select Tools, Internet Options, Connections, LAN Settings. Alternate web browser menu selections may differ.
3	Uncheck the Use a proxy server box.

In the address bar of your browser, enter the IP address of the AP/BHM. (For example, enter <http://169.254.1.1> to access the AP/BHM through its default IP address). The AP/BHM responds by opening the **General Status** tab of its **Home** page.

Logging into the web interface – AP/SM/BH

Procedure 4 Logging into the web interface

1	Plug one end of a CAT 5 Ethernet cable into the AP/BHM
2	Plug the Ethernet cable connector labeled To Radio into the jack in the pig tail that hangs from the power supply.
3	Plug the other connector of the pig tail (this connector labeled To Computer) into the Ethernet jack of the computing device.
4	Plug the power supply into an electrical outlet.  Warning From this point until you remove power from the ODU, stay at least as far from the ODU as the minimum separation distance specified.

Using the Quick Start Configuration Wizard of the AP/BHM

See section Quick Link Setup section in *Configuration Guide*.

Chapter 5: Installation

This chapter describes how to install and test the hardware for a 450 Platform family series.

The chapter covers the following topics:

- [ODU variants and mounting bracket options](#)
- [Mount the ODU, LPU and surge suppressor](#)
- [Installation](#)
- [Installing external antennas to a connectorized ODU](#)
- [Installing ODU](#)
- [Installing the AC Power Injector](#)
- [Supplemental installation information](#)



Note

These instructions assume that LPUs are being installed from the 450 Platform Family LPU and grounding kit (Cambium part number C000065L007). If the installation does not require LPUs, adapt these instructions as appropriate.

If LPUs are being installed, only use the five black-capped EMC cable glands supplied in the LPU and grounding kit. The silver-capped cable glands supplied in the ODU kits must only be used in 450 Platform installations which do not require LPUs.

ODU variants and mounting bracket options

Mounting bracket— PMP/PTP 450i Series

The PMP/PTP 450i Series supports below mentioned mounting bracket option:

Table 140: PMP/PTP 450i Series - ODU mounting bracket part numbers

Cambium description	Cambium part number
Mounting bracket – low profile adjustable	N000045L002A

The low-profile bracket provides elevation adjustment with the PMP/PTP 450i Series Integrated ODUs of +10° to –5° or +5° to –10°. A larger adjustment range is available using the standard integrated mounting bracket. The connectorized mounting bracket does not provide elevation adjustment.

Mounting bracket– PMP 450 Series – SM 900 MHz

The PMP 450i Series – SM 900 MHz has special mounting bracket option. The PMP 450i Series AP - 900 MHz mounting procedure is the same as the other 450i Series radios. The 450 Series SM 900 MHz has a different mounting bracket which is supplied along with Yagi antenna.



Mount the ODU, LPU and surge suppressor

To install the ODU and top LPU, use the following procedures:

- [Attach ground cables to the ODU](#)
- [Mount the ODU on the mast](#)
- [Mount the top LPU](#)
- [Mount the Surge Suppressor](#)

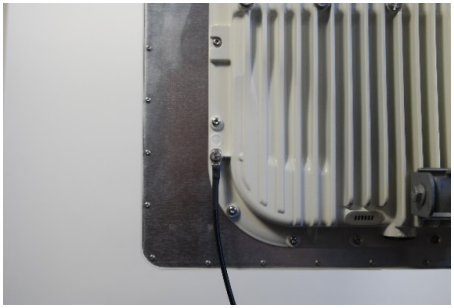

Attach ground cables to the ODU

PMP 450m Series – AP



1	Fasten an AWG 10 (or 6mm ²) copper ground cable to each ODU grounding point using the M6 (small) lugs.	
2	Secure the M6 grounding bolts by applying 3 Nm torque.	

3	Securely connect the copper wires to the grounding system (Protective Earth) and the LPU or Gigabit Ethernet Surge Suppressor according to applicable regulations.	
---	--	--

PMP/PTP 450i Series – AP/SM/BH, PMP 450 3 GHz Ruggedized SM

1	Fasten an AWG 10 (or 6mm ²) copper ground cable to each ODU grounding point using the M6 (small) lugs.	
2	Tighten the Ground post screws.	
3	Securely connect the copper wires to the grounding system (Protective Earth) and the LPU or Gigabit Ethernet Surge Suppressor according to applicable regulations.	

PMP 450 AP

1	Fasten an AWG 10 (or 6mm ²) copper ground cable to each ODU grounding point using the M6 (small) lugs	
2	Tighten the Ground post locking nut in the copper wire	
3	Securely connect the copper wire to the grounding system (Protective Earth) according to applicable regulations.	

PMP 450 SM

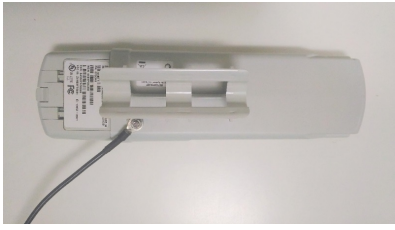
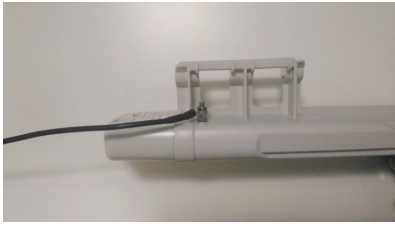
1	Fasten an AWG 10 (or 6mm ²) copper ground cable to each ODU grounding point using the M6 (small) lugs	
2	Tighten the Ground post locking nut in the copper wire	
3	Securely connect the copper wire to the grounding system (Protective Earth) according to applicable regulations.	

The grounding point on PMP 450 Series SM 900 MHz is different from 2.4, 3.5/3.65 and 5 GHz PMP 450 SMs as shown in [Installation](#).

Figure 107: PMP 450 900 MHz SM grounding

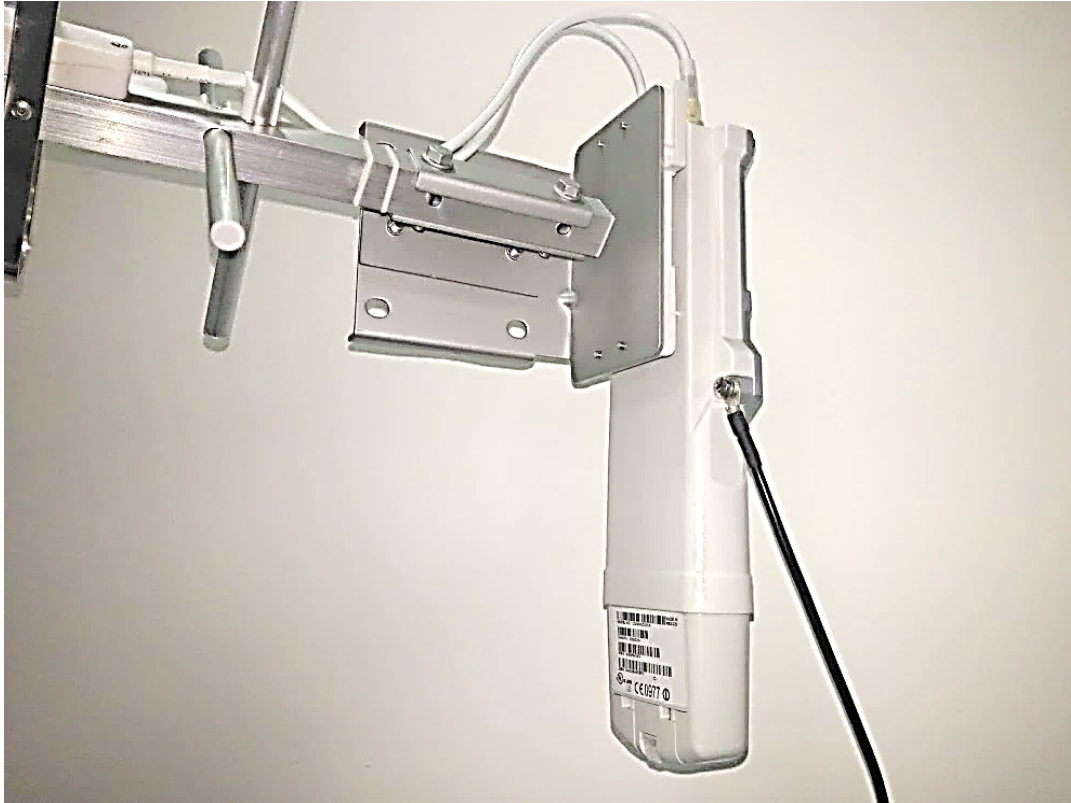

Mount the ODU on the mast

PMP 450m Series – AP

1	See - PMP 450m Series – 5 GHz AP for Installation for an integrated ODU	
2	Remove the rear bracket strap from upper and lower brackets of ODU	
3	Attach the upper and lower bracket of ODU to the mount point by closing the rear strap around the pole	
4	Secure the four-serrated flange M8 nuts by applying 10 Nm torque on upper and lower rear strap using a 13 mm spanner wrench. These must be tightened evenly on the pole to avoid jumping/stripping threads	
5	Secure the bolts on four sides by applying 8 Nm torque as per the angle of the antenna.	

PMP/PTP 450i Series – AP/SM/BH, PMP 450 3 GHz Ruggedized SM



Caution

Do not reverse the bracket clamp, as this arrangement may lead to failure of the assembly. Do not over-tighten the bolts as this may lead to failure of the assembly.

1	Fix the mounting plate to the back of the ODU using the four bolts, and spring and plain washers provided. Tighten the bolts.	
2	Attach the bracket body to the mounting plate using the M8 bolt, spring and plain washers.	
3	Hoist the ODU to the mounting position	
4	Attach the bracket body to the pole using the bracket clamp, M8 bolts, and spring and plain washers.	
5	Adjust the elevation and azimuth to achieve visual alignment.	

PMP 450b Mid-Gain SM

1	Use a stainless-steel hose clamp for the attachment.	
2	Attach the mounting bracket to the structure with the release tab facing downward. Tighten the hose clamp.	
3	Slide the 450b SM onto the mounting bracket. Press downwards until it clicks into place.	

4	Loosen the adjuster wingnut on the bracket and set the required SM tilt angle. Retighten the adjuster wingnut by hand to secure the SM at the chosen angle.	
---	---	--

PMP 450b High Gain – IP55 Version

The 450b High Gain unit is supplied as an IP55 version from Q4 2019. Follow the assembly instructions below for the IP55 version. Conversion of an IP55 unit to IP67 requires the purchase of kit N000000L135A and assembly instructions are covered in subsequent sections.

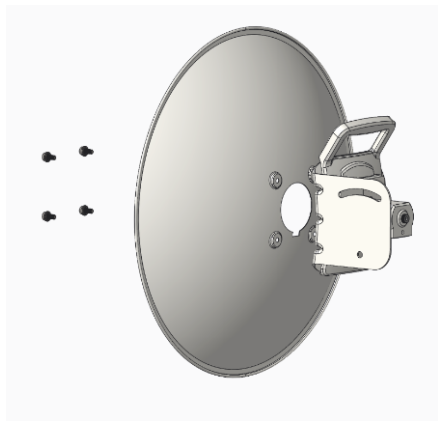

Tools required are:

- 5mm Allen key
- 13mm wrench
- Torque wrench

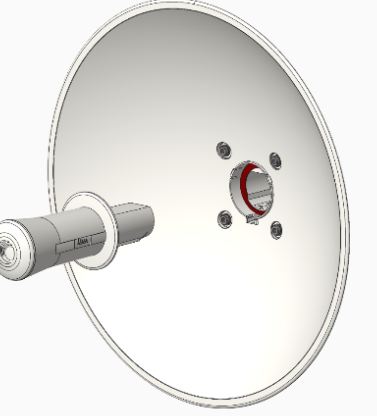
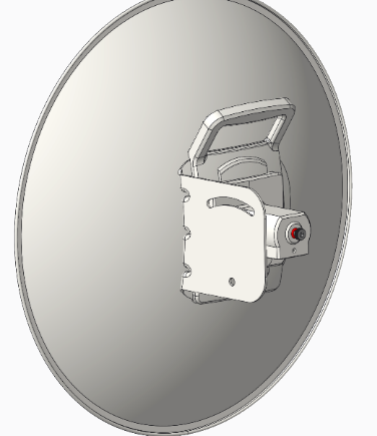
1	Snap in the rear housing assembly.	
---	------------------------------------	--

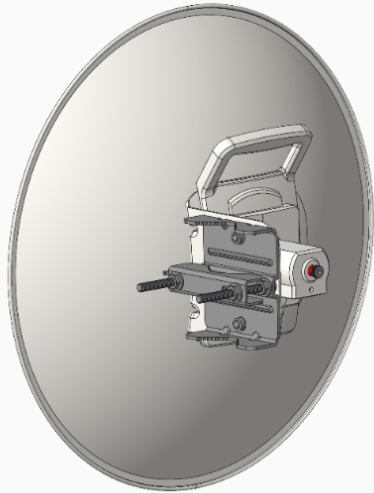
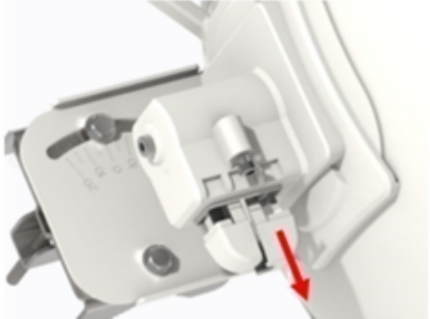

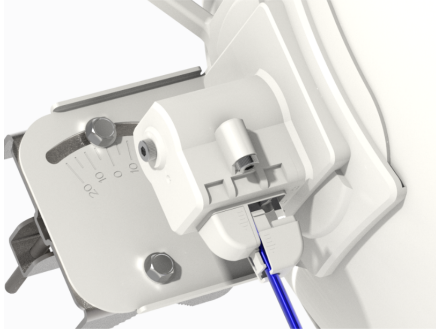
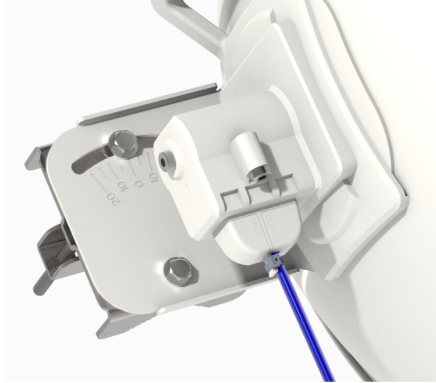
2	<p>Insert screws to hold the rear housing assembly to the dish and tighten to a 10 Nm torque.</p>	 A 3D perspective view of the back of a satellite dish. A central feed horn assembly is mounted. Six screws are shown being inserted into pre-drilled holes around the perimeter of the dish's rear panel to secure it.
3	<p>Snap in the center feed tube (radio) to the assembly.</p>	 A 3D perspective view of the back of the dish. The central feed horn assembly is now fully attached. A cylindrical center feed tube is being pushed into the central feed horn from the left side.
4	<p>Tighten the center feed tube lock screw to a maximum of 5 Nm. Do not overtighten to avoid damaging the feed tube.</p>	 A 3D perspective view of the back of the dish. The center feed tube is now fully inserted and secured. A lock screw is being tightened onto the end of the feed tube to lock it in place.

5	<p>Assemble the pole bracket to the Rear housing bracket, using the M8 bolts</p>	
6	<p>Slide the cover onto the body of the radio, ensuring that the two sliding rails engage with the slots in the dish body. Attach and tighten the two cover screws to the body. Tighten to 5 Nm torque.</p>	
7	<p>Unclip the door nearest the dish by squeezing at the two thumb marks.</p>	

8	<p>Connect the RJ45 connector to the radio and replace the door.</p>	
9	<p>Use a tie wrap to secure the Ethernet cable to center post of the cover.</p>	
10	<p>On the pole bracket, loosen the M8 nuts to remove outer clamp. Slip clamp over pole and tighten M8 nuts by applying 8 Nm torque. Do not over tighten to prevent aligning the dish.</p> <p>After alignment, ensure that the two bracket bolts and two pole clamp nuts are tightened to 25 Nm.</p>	

Fitting a synchronization cable to the aux port

For PTP Backhaul Master applications requiring synchronization, a synchronization cable may be fitted to the aux port as described below. Before installation of the 450b, prepare the cover as per the steps below:

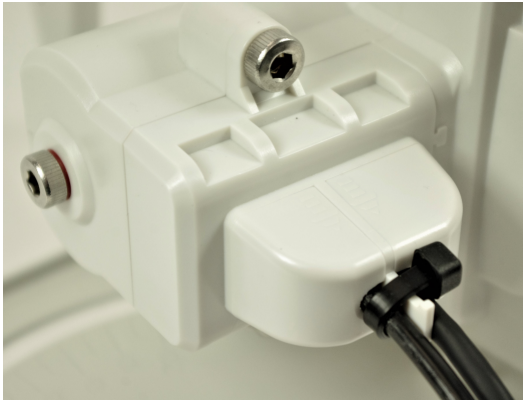

1	Locate an IP55 cover from the dish kit.	
2	Unclip the rear door and locate the breakout.	
3	Use pincers to break out the piece of plastic and trim with a sharp blade. Check that synchronization cable fits the opening.	

4	Assemble unit as in steps 1 to 8 above.	
5	Connect the synchronization cable to the rear 3.5 mm jack socket and replace the door.	
6	Continue with steps 9 and 10 above ensuring both cables are secured to the center post with a tie wrap.	

PMP 450b High Gain – IP67

To convert an IP55 version of the PMP 450b High Gain to an IP67 version, kit N00000L135A is required. This kit contains 4 off IP67 door/ glands. Follow the fitting instructions 1-5 in section [PMP 450b High Gain – IP55 Version](#) above and then the steps below. Note that a permanent connection to the AUX port is not available when using this kit.

1	Locate an IP67 door/gland from kit N00000L135A.	
---	---	--

2	<p>Remove the cable gland from bottom cover. Feed the RJ45 cable through the gland, bottom cover and connect to the radio.</p>	
3	<p>Keep part loose and screw gland to the bottom cover. Audio cable is not shown in the figure.</p>	

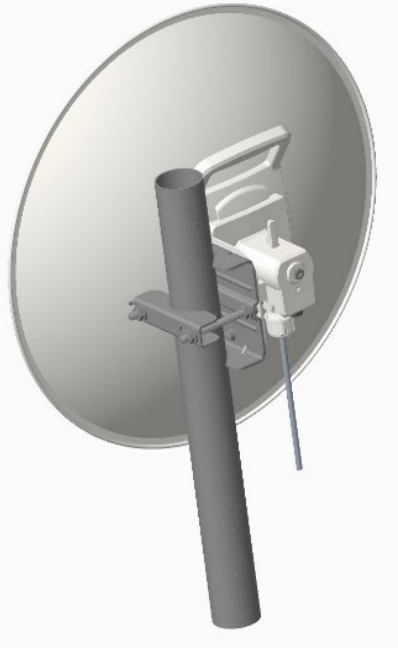
4	<p>Tighten gland, bottom cover screws and connect to the radio.</p>	
5	<p>On the pole bracket, loosen the M8 nuts to remove outer clamp. Slip clamp over pole and tighten M8 nuts by applying 8 Nm torque. Do not over tighten to prevent aligning the dish.</p> <p>After alignment, ensure that the two bracket bolts and two pole clamp nuts are tightened to 25 Nm.</p>	

PMP 450 MicroPoP - Omni

1. Assemble the pole mounting bracket to the radio with two screws.

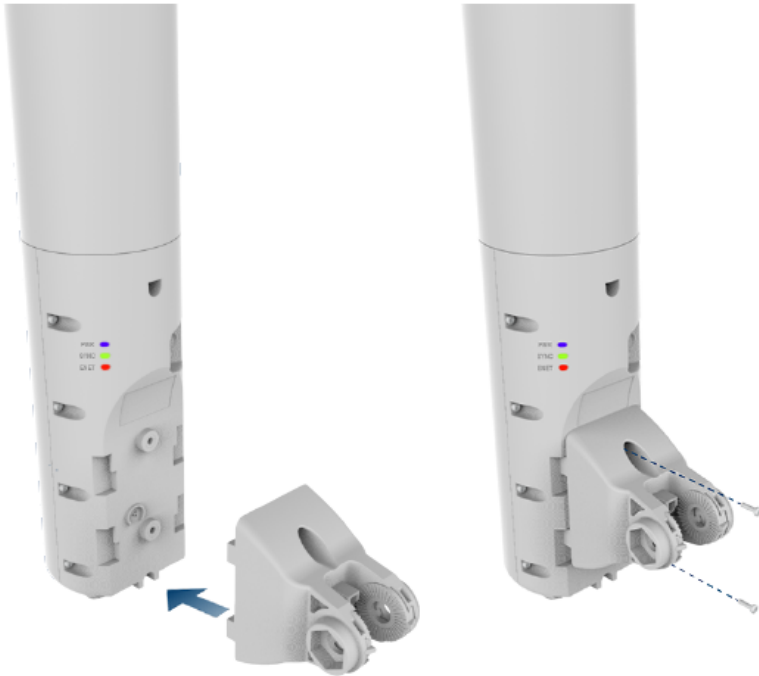

2. Secure pole mounting bracket to the radio with M8 nut and bolt by applying 3.0 Nm torque.



3. Insert hose clamps through the pole mounting bracket and attach to pole by applying 3.0 Nm torque.



4. Remove the cable gland from bottom of the radio. Feed the RJ45 cable through the gland, bottom cover and connect to the radio.



PMP 450 MicroPoP - Sector

1. Assemble the pole mounting bracket to the radio with two screws.

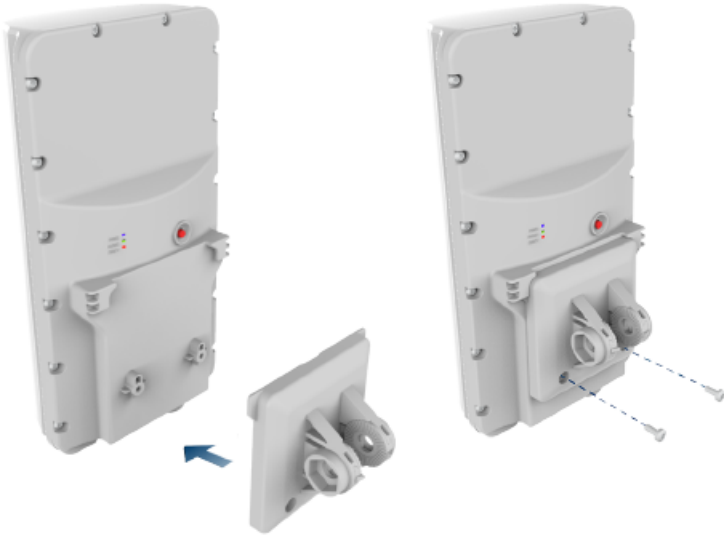

2. Secure pole mounting bracket with M8 nut and bolt by applying 3.0 Nm torque.

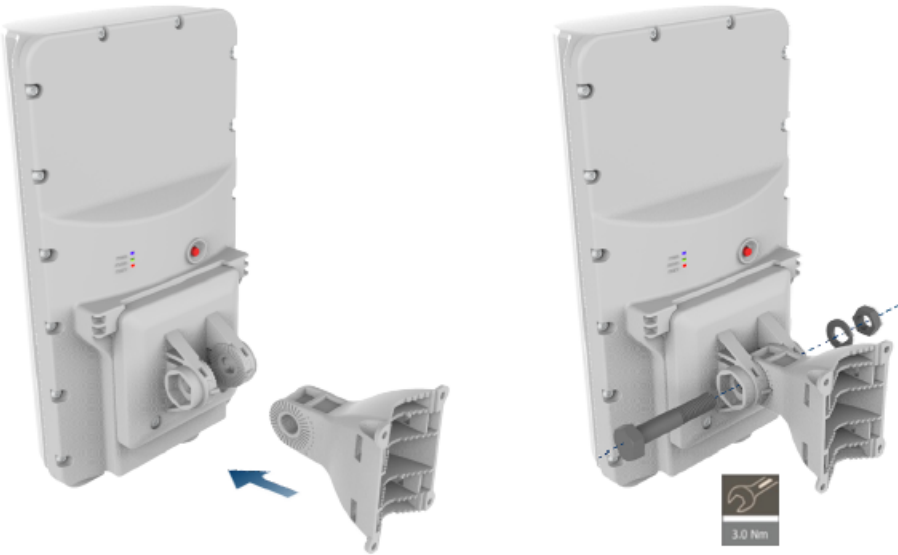

3. Insert hose clamps through pole mounting bracket and clamp to pole by applying 3.0 Nm torque.

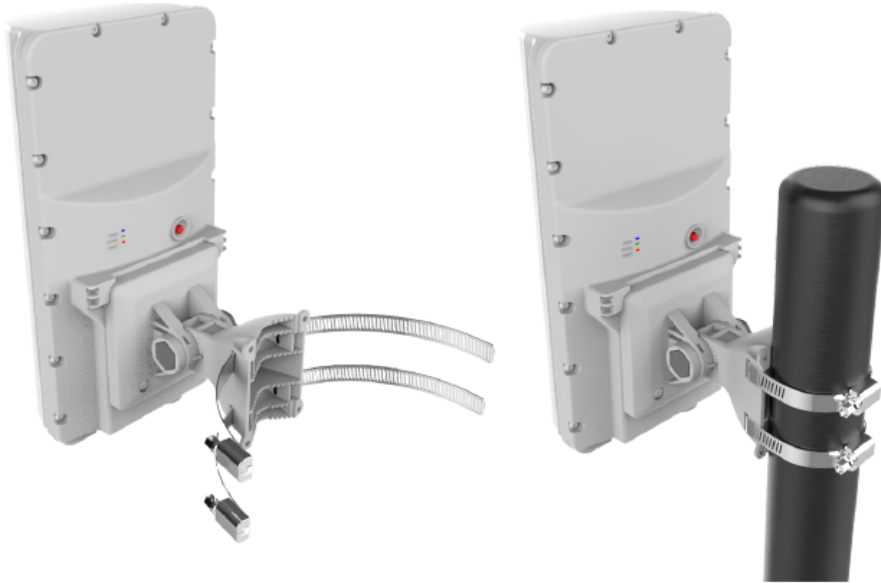

4. Remove the cable gland from bottom of the radio. Feed the RJ45 cable through the gland, bottom cover and connect to the radio.



5. Align radio to required angle by tilting up and down. The maximum radio tilting angle is $\pm 40^\circ$, with an incremental of 10° . Secure radio with max 5.0 Nm torque.



PMP 450 MicroPoP - Connectorized

1. Assemble the pole mounting bracket to the radio with two screws.
2. Secure pole mounting bracket to the radio with M8 nut and bolt by applying 3.0 Nm torque.

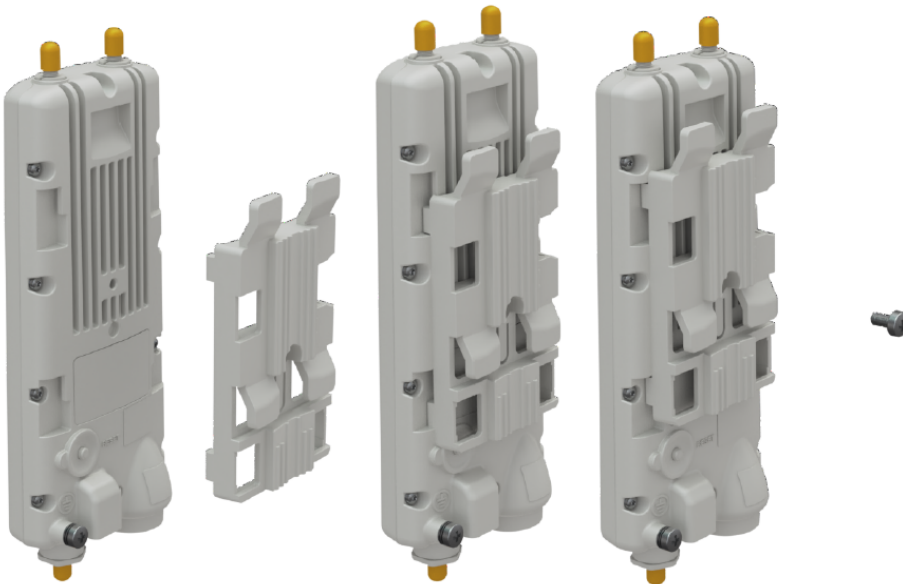

3. Insert hose clamps through the pole mounting bracket and attach to pole by applying 3.0 Nm torque.

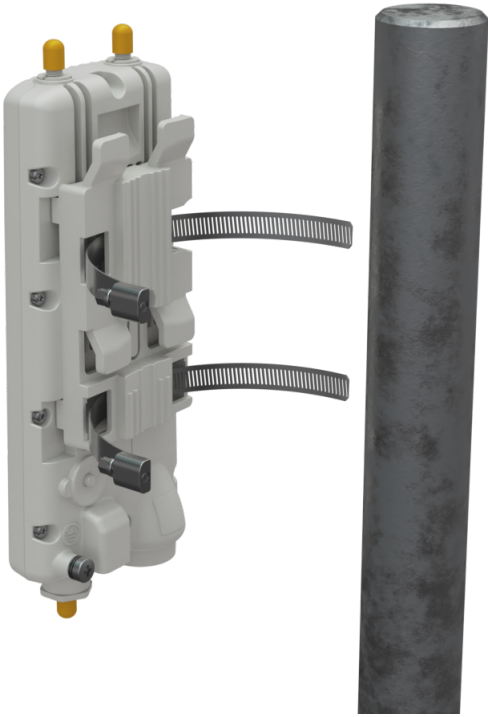

4. Remove the cable gland from bottom of the radio. Feed the RJ45 cable through the gland, bottom cover and connect to the radio.



PMP 450b Retro

Pole Mount

1. Insert hose clamps on the device bracket and attach to the pole by applying 3.0 Nm torque.



2. Release the bottom cap and insert RJ45 cable on the bottom of the device.



3. Place the cap back on the device after the cable installation.



Dish Mount

1. Slide the device into the dish slot as shown in the below figure.



2. Insert hose clamps on the device bracket and attach to the dish by applying 3.0 Nm torque.



3. Release the bottom cap and insert RJ45 cable on the bottom of the device.



4. Place the cap back on the device after the cable installation.



450v AP

1. Attach the brackets to the antenna and radio with a torque of 5 Nm torque.

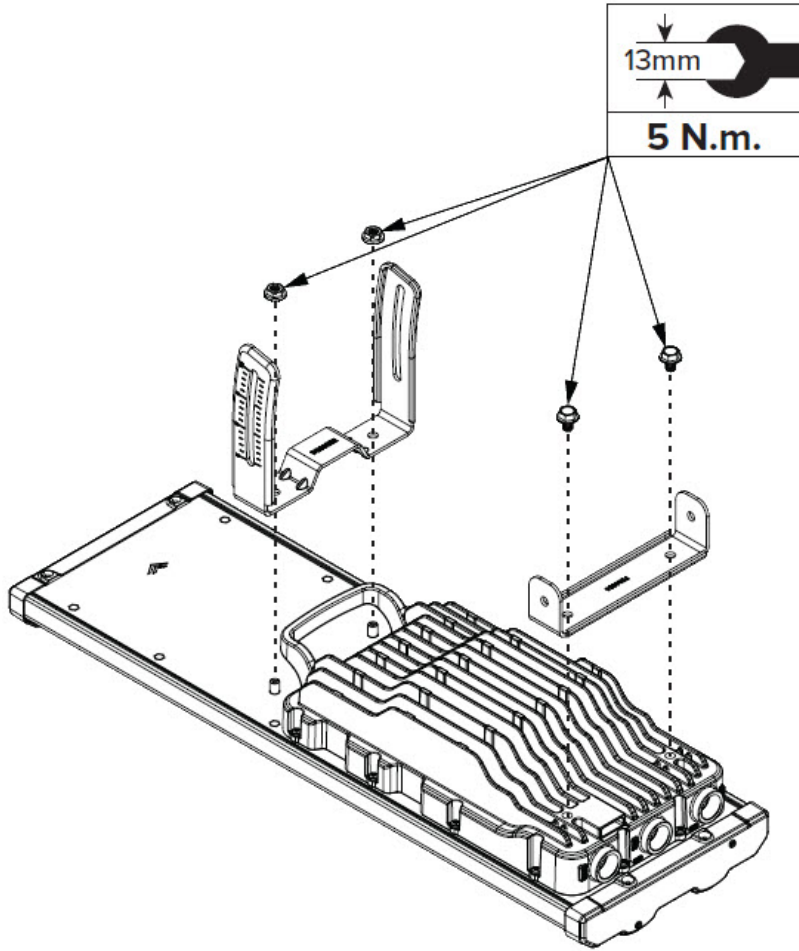

2. Attach the pole mounting brackets to the radio. Fully tighten the top screws with 5 Nm torque, and keep the vertical screws loosened. Tighten the loosened screws (3 Nm torque) later during angle adjustment.

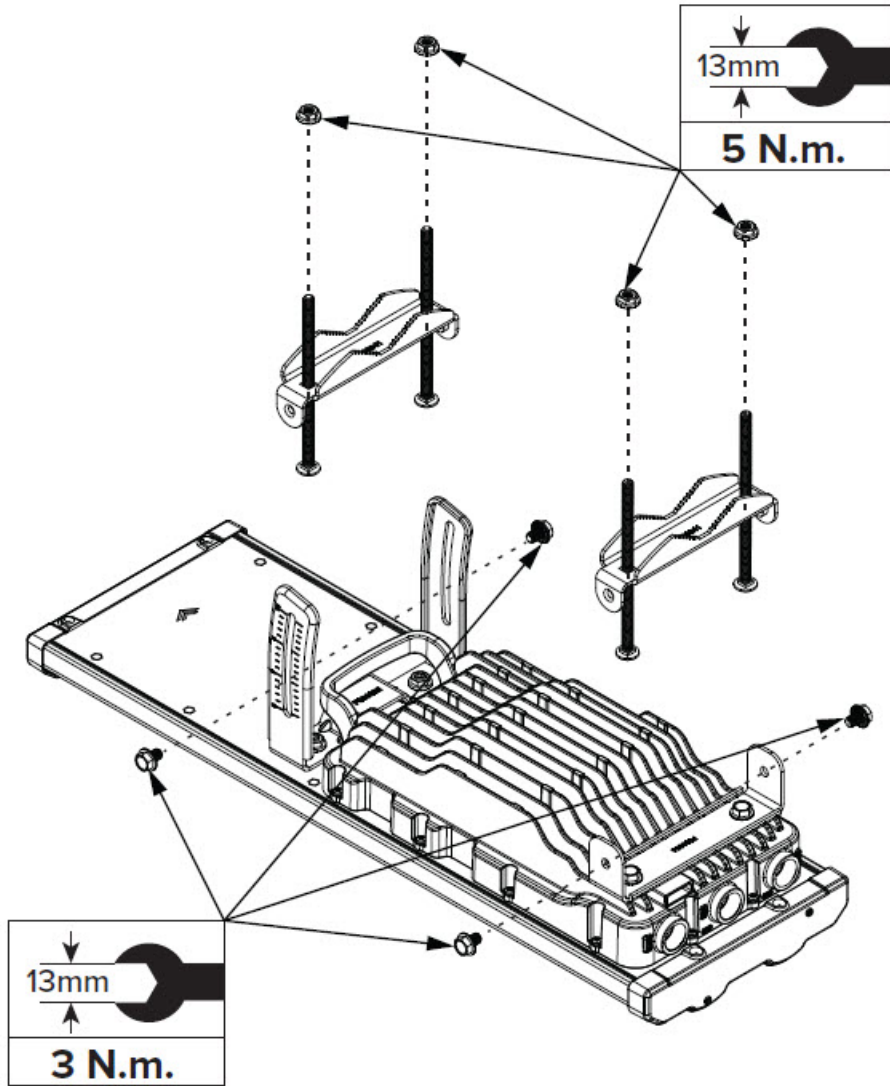

3. Fit the nuts for pole mount loosely, and avoid tightening them.

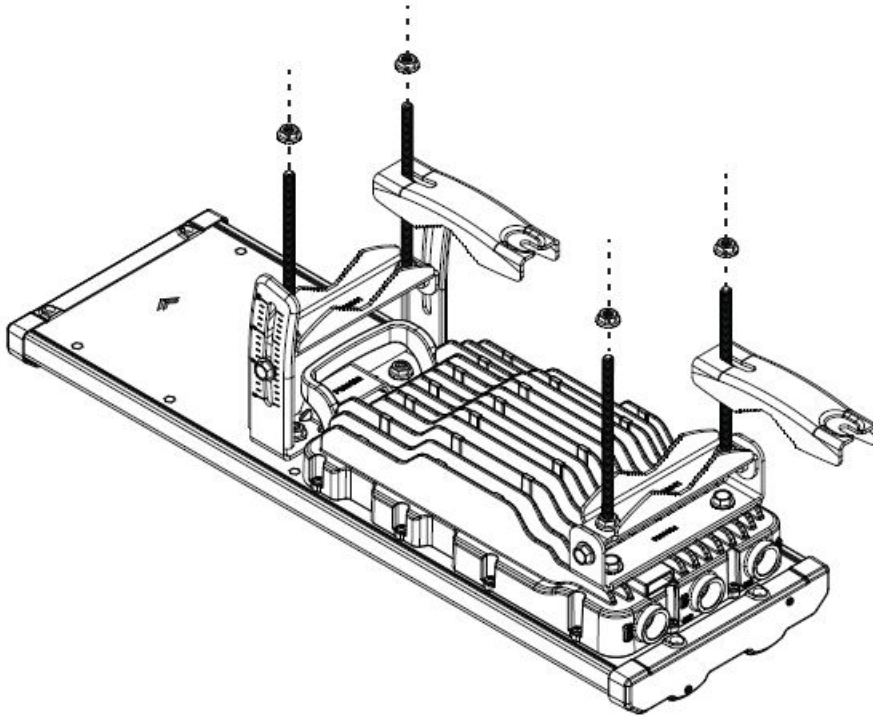

4. Adjust the brackets and tighten the nuts onto the pole mount.

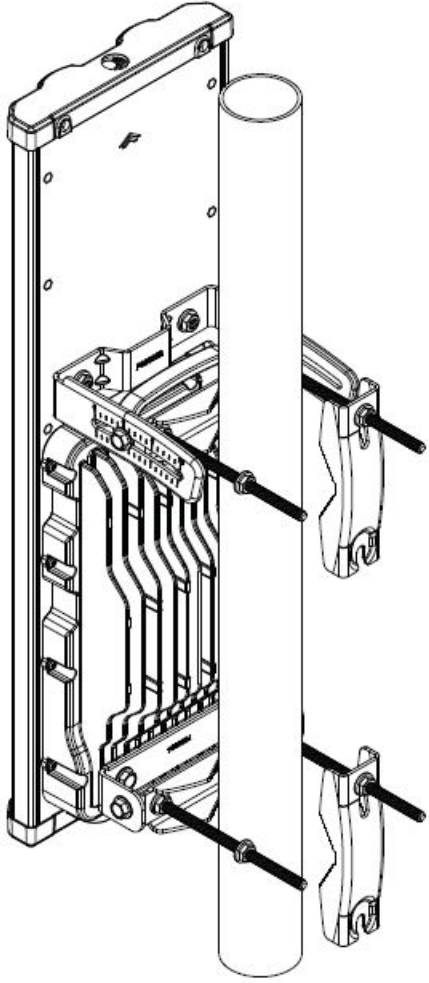

5. Tighten the nuts onto the pole mount with 5 Nm torque.

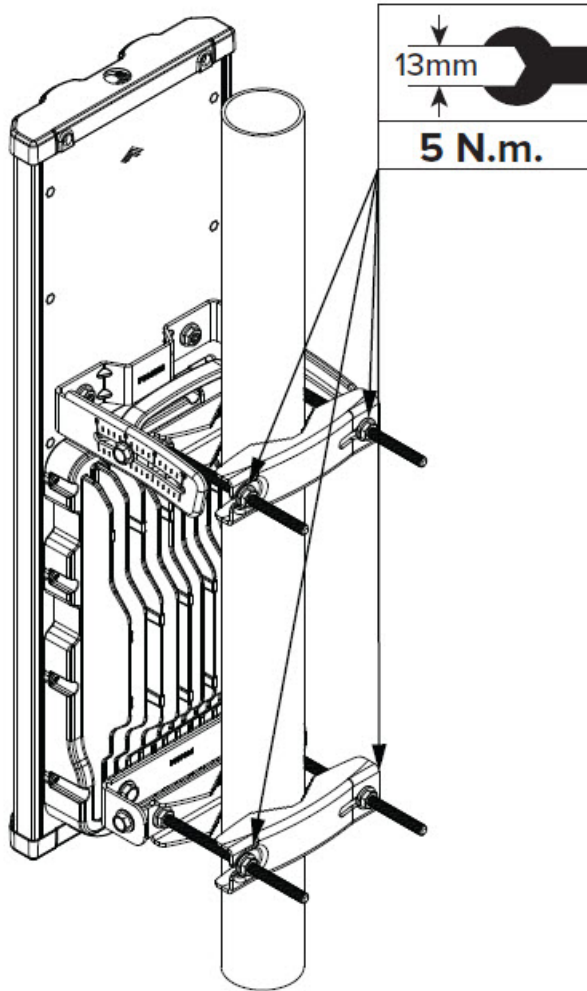

6. Connect all the ports and secure the cable glands.

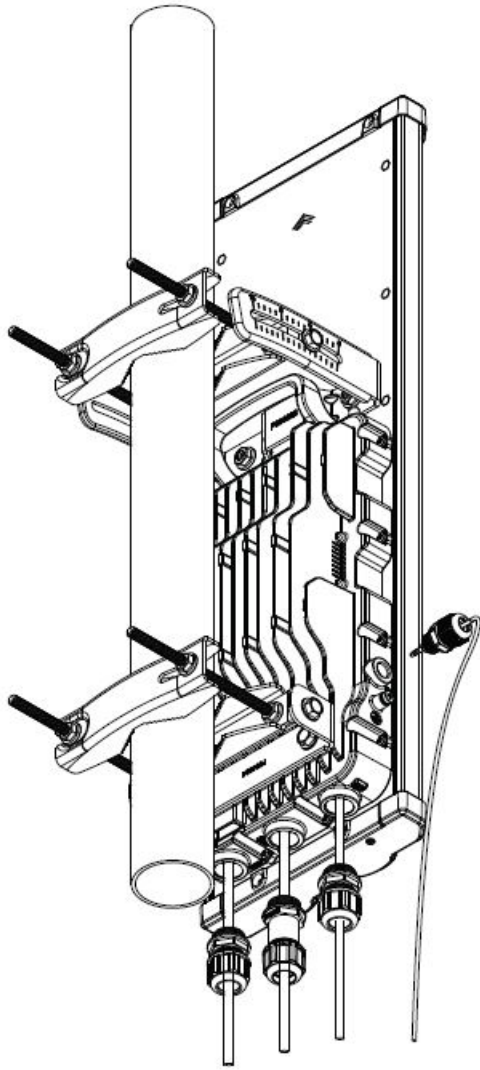

7. Slightly loosen the bolt, adjust the angle, and then tighten to 5 Nm torque.

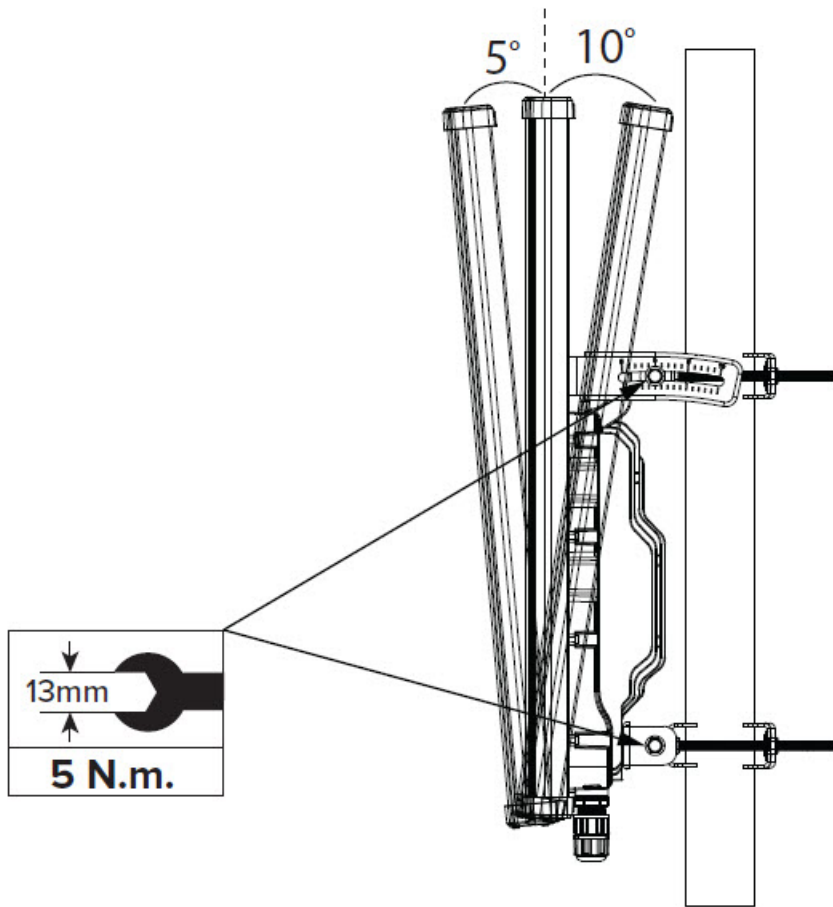

450v SM/BHM/BHS (4X4)

1. Assemble the subreflector with the dish using the screws and apply 1.6 Nm torque.

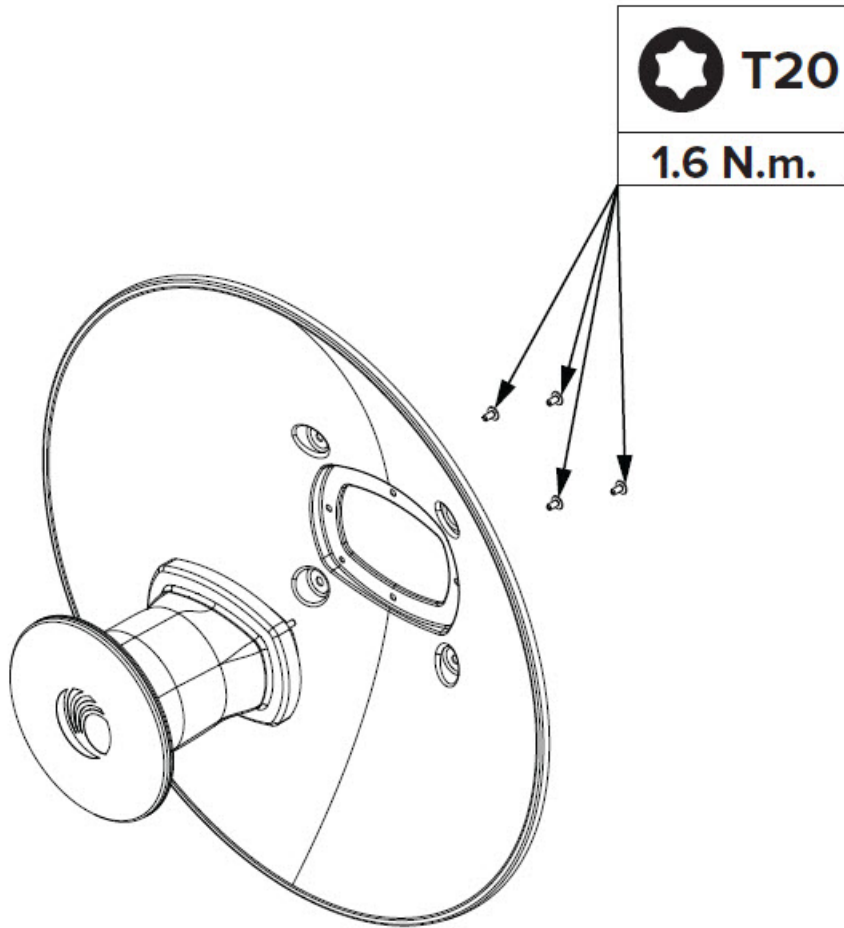

2. Connect the L bracket to the dish using screws. Apply 6 Nm torque, ensuring alignment with the subreflector. You can attach the L bracket to the dish, either on the left-hand side (Option 1) or the right-hand side (Option 2) depending on the pole's location.

OPTION 1

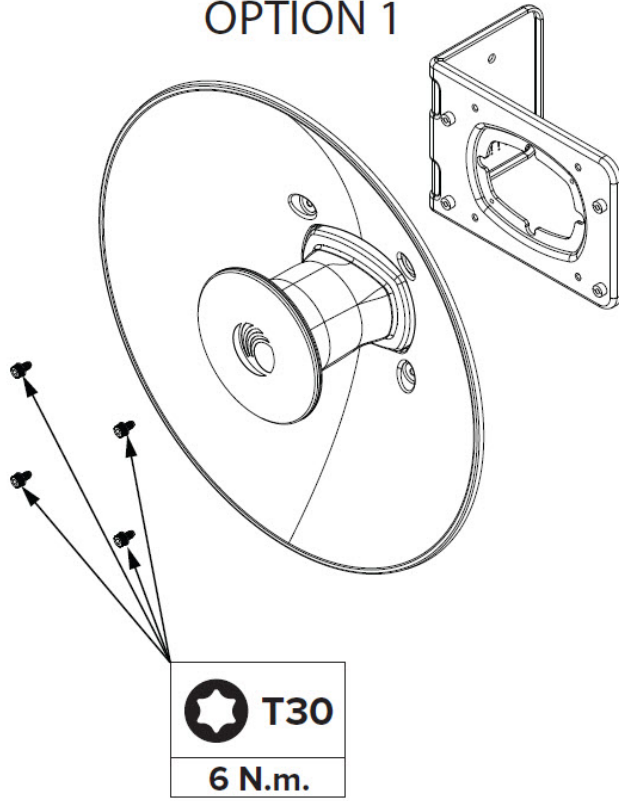

OPTION 2

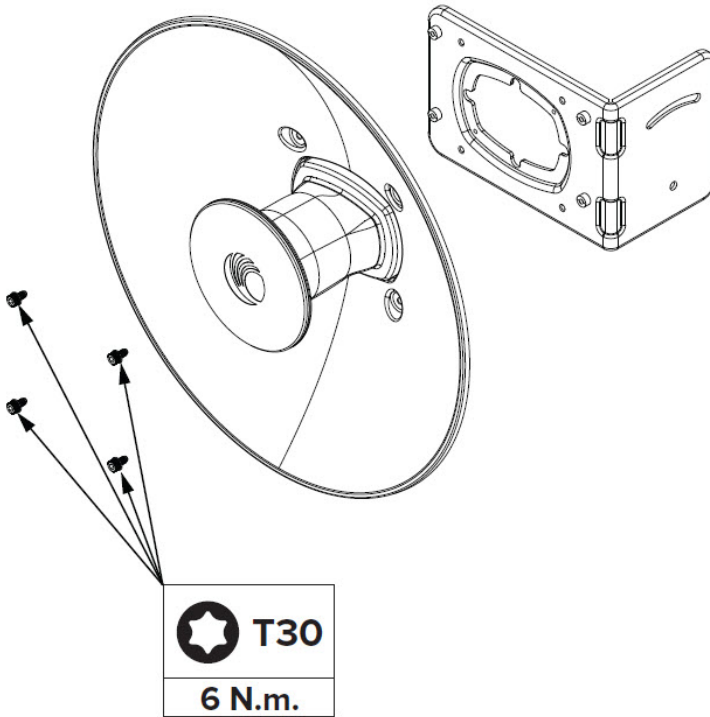

3. Assemble the pole mount bracket. Tighten the first two screws with 5 Nm torque. Keep the second set of screws loosely mounted for attachment to the pole later.

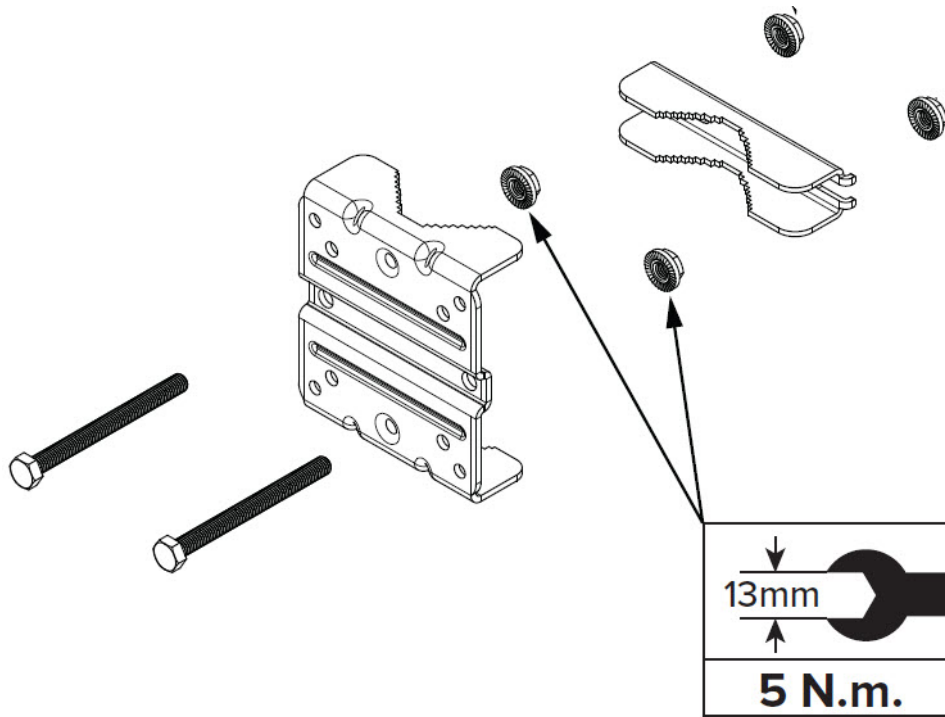

4. Attach the pole mount bracket to the L bracket with 1 Nm torque. Tighten it further after angle adjustments.

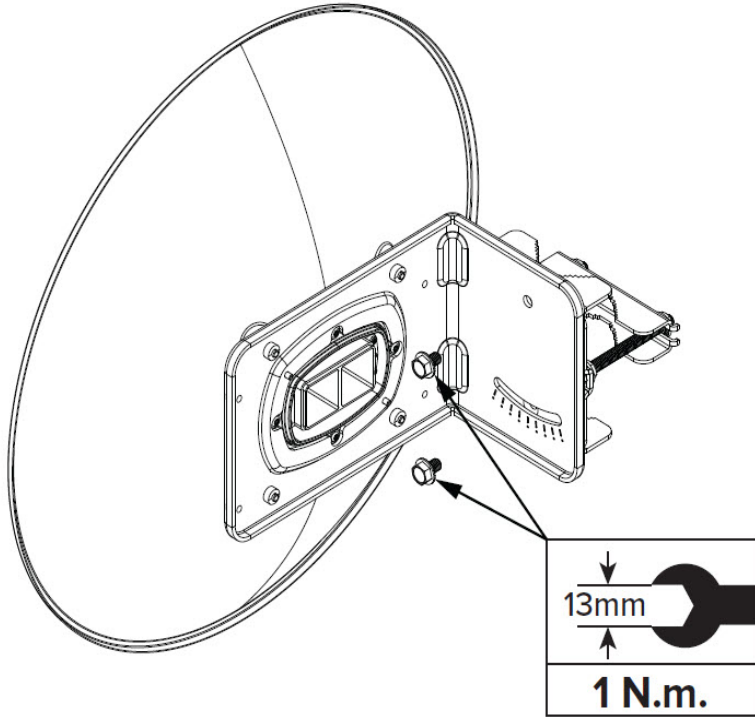

5. Attach the radio to the assembled pole and L bracket with the provided screws, applying 6 Nm torque.

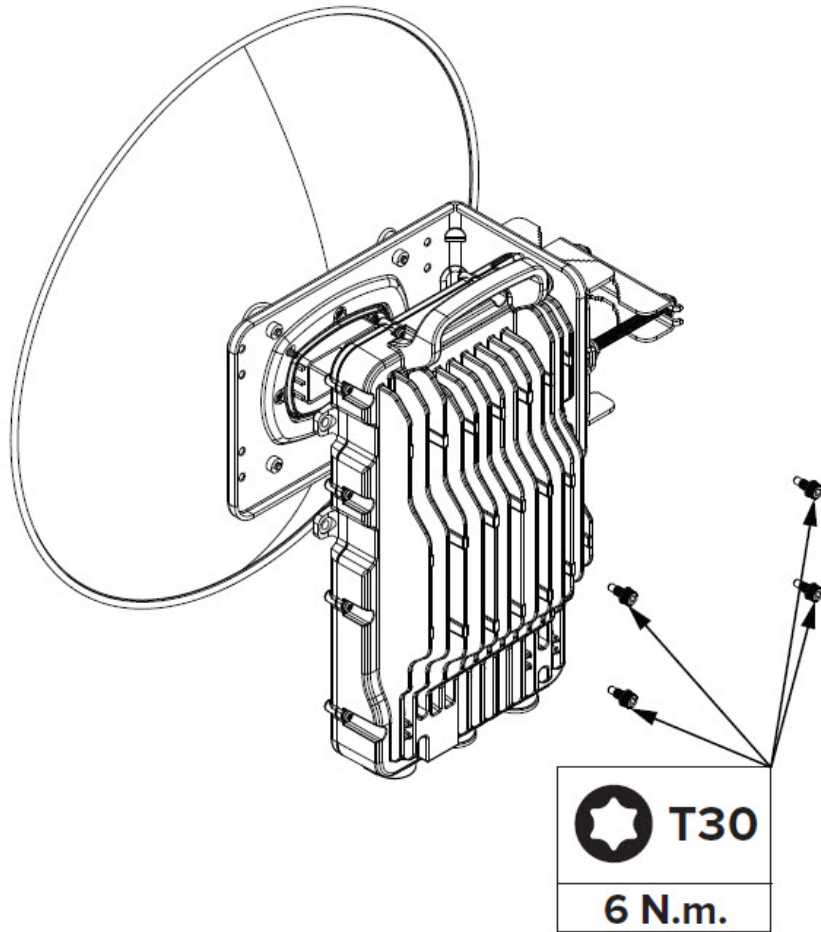

6. Tighten the pole mount attachment with 10 Nm torque (Previously instructed to be loosely tightened). The recommended pole diameter is 40–70 mm, and it must not be less than 35 mm in diameter.

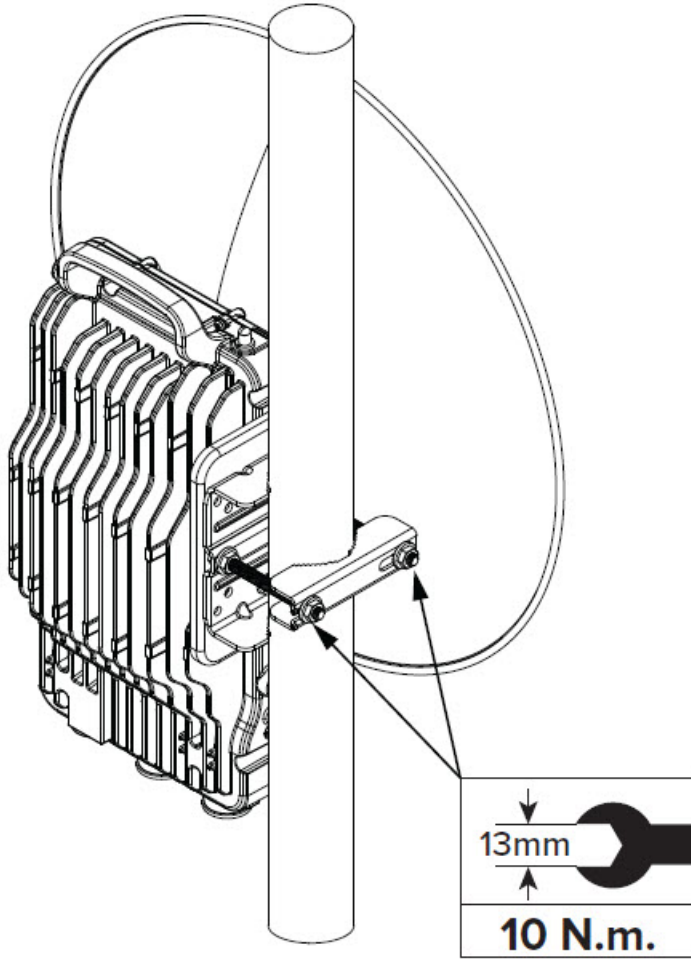

7. Connect all the ports and secure the cable glands.

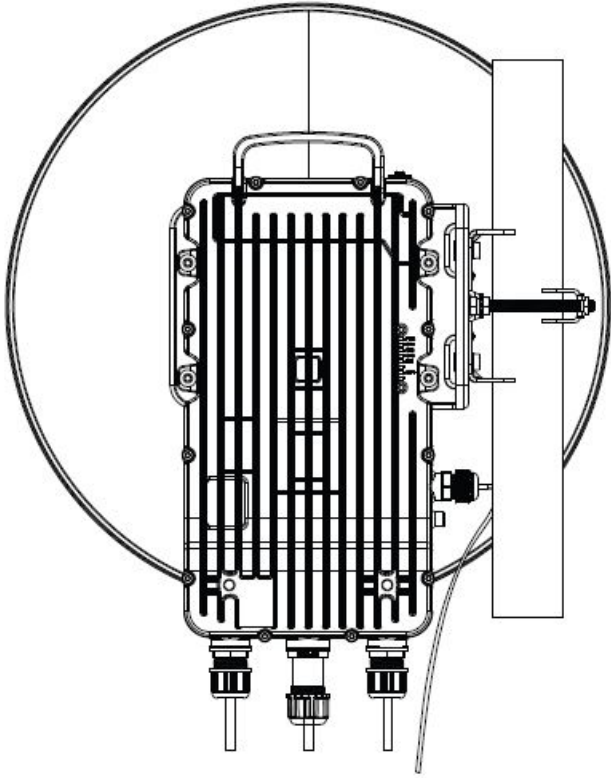

8. Align the dish and tighten the angle adjustments with 8 Nm torque.

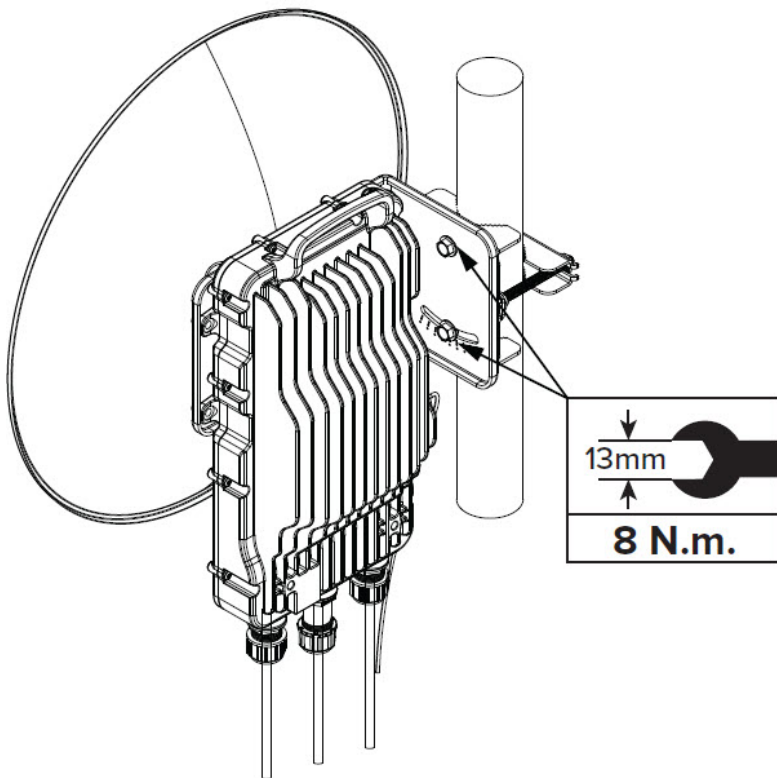
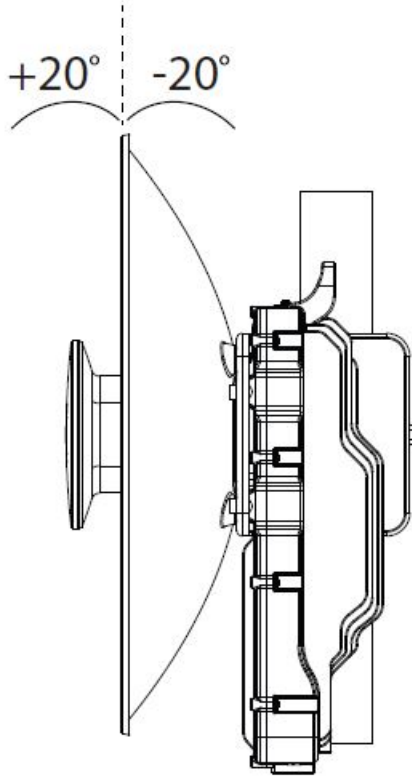

450v SM/BHM/BHS (2x2)

1. Bracket placement:

You have two options for placing the bracket: either on the left-hand side (Option 1) or the right-hand side (Option 2), depending on the pole's availability or accessibility. The following instructions continue with Option 1, where the bracket is placed on the left-hand side.

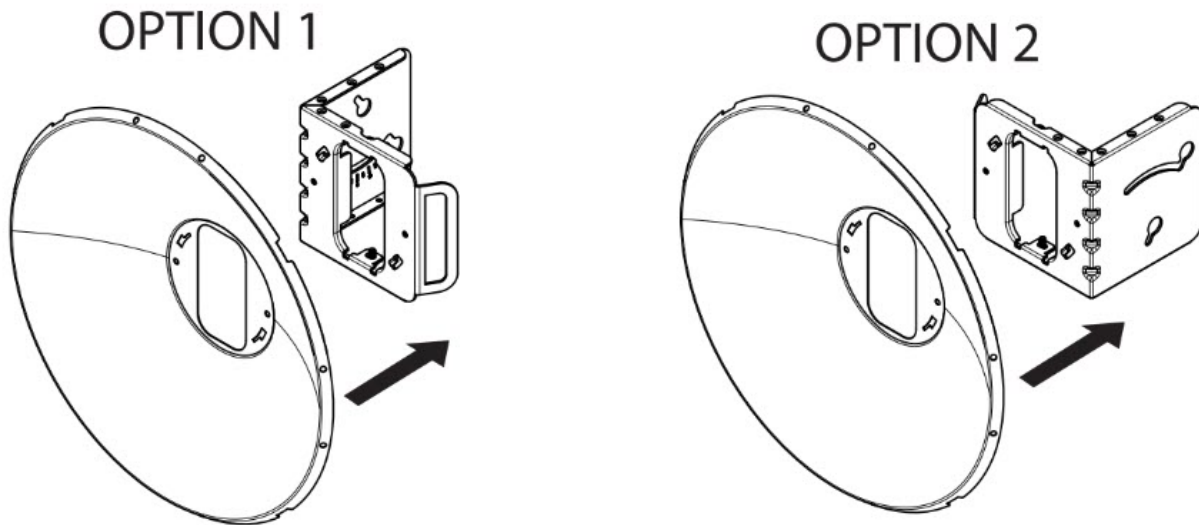

2. Locking the bracket on the dish:

Lock the bracket onto the dish by aligning it with the grooves closer to the dish. Push the bracket into the dish and twist it to the left-hand side. Once the bracket locks into place, secure it with an M6 screw, applying 5 Nm torque.

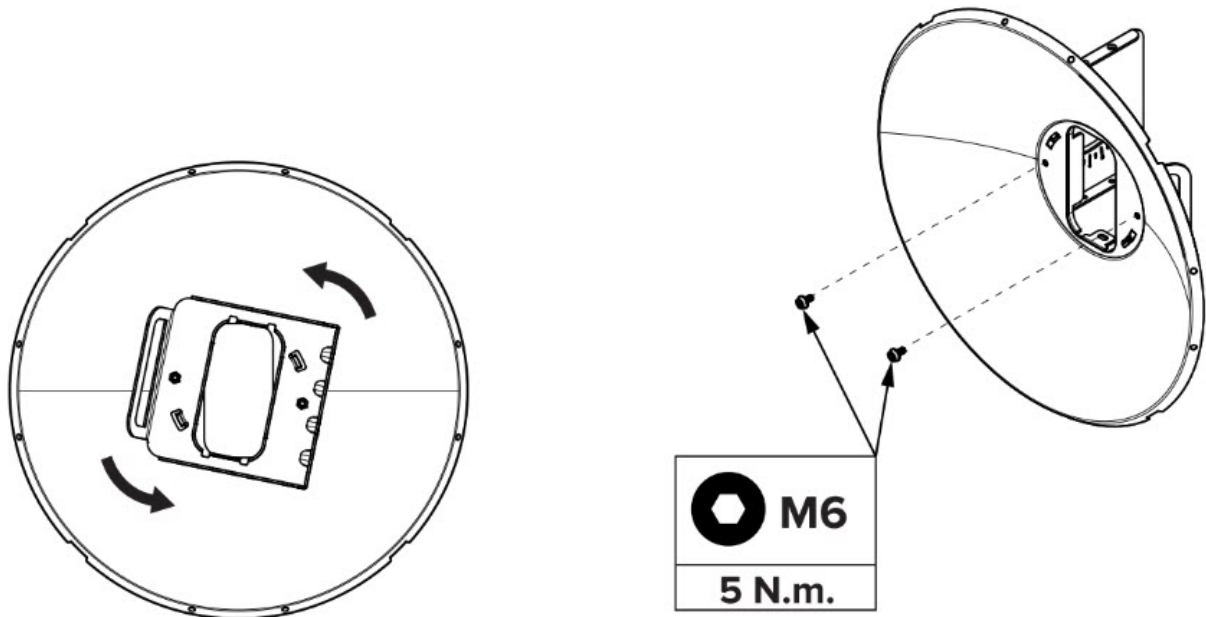

3. Assembling the Radio:

Slide the radio into position on the bracket. Secure the radio by adding an M6 screw on the back side and tightening it with 5 Nm torque.

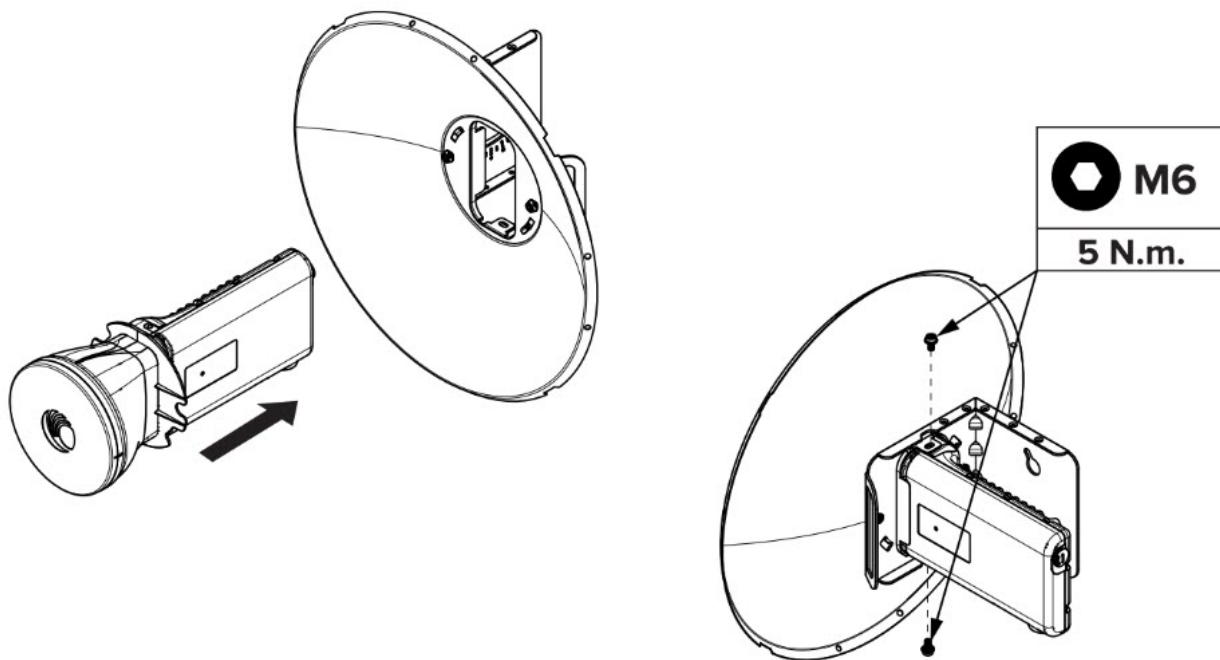

4. Pole mount bracket preparation:

The pole mount bracket comes pre-assembled in the box. Place it on the pole and loosely fit the nut on the pre-assembled pole mount bracket. Do not tighten the nut at this stage.

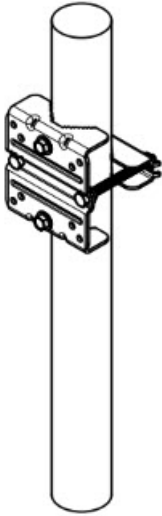

5. Attaching the dish assembly:

Slide the dish assembly into the loose screw head of the pole mount bracket. The dish assembly includes grooves that will align with the screw head and allow the assembly to fall into place.

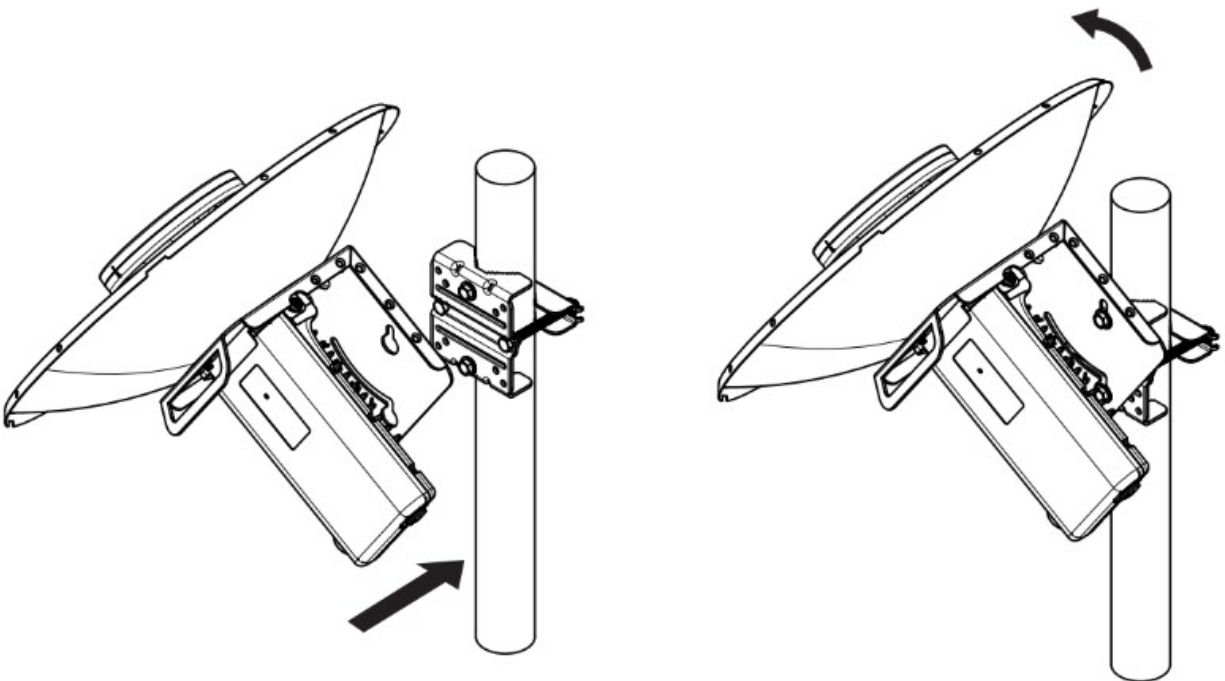

6. Final adjustments:

After determining the correct angle for the dish, tighten the screws to secure the dish. Connect all the ports and fix the cable glands.

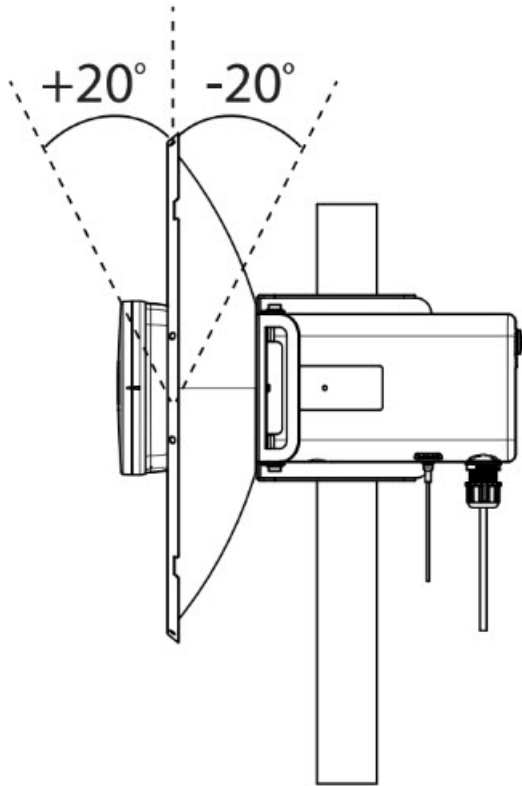

7. Final tightening:

Align the radio, and tighten the pole mount bracket with 10 Nm torque. Secure the dish brackets with 8 Nm torque.

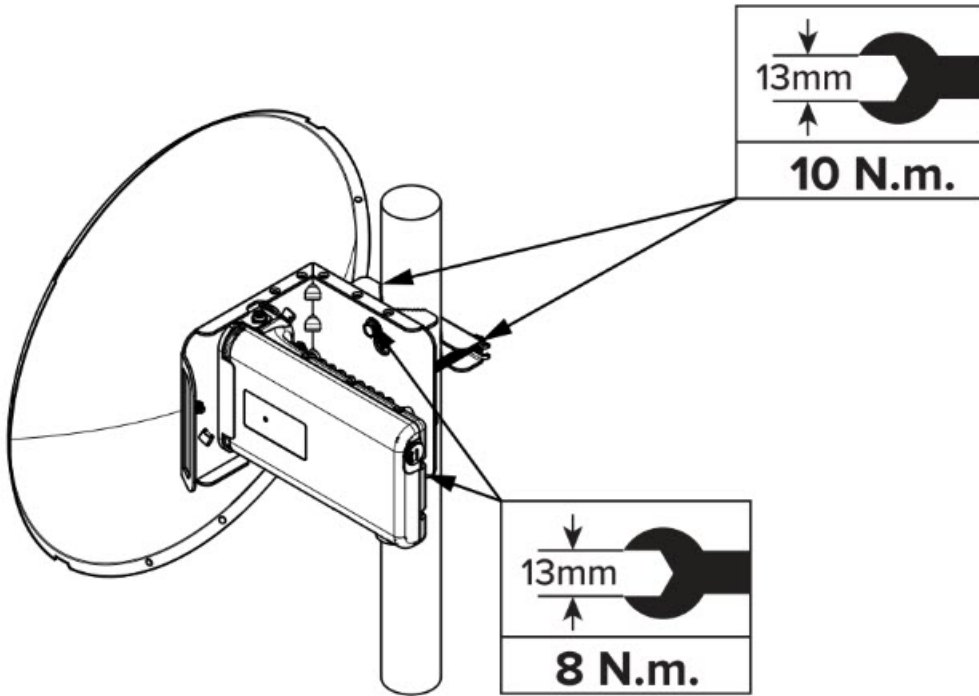

PMP 450 AP

1	<p>Using an 8mm nut driver, attach the pole mount's AP housing bracket to the unit using the 4 M5 x 16mm bolts included with the AP.</p>	
2	<p>Using the included (depending on pole diameter):</p> <ul style="list-style-type: none"> • M8 x 70mm hex cap bolts (2 quantity) <p>or</p> <ul style="list-style-type: none"> • M8 x 40mm hex cap bolts (2 quantity) <p>and</p> <ul style="list-style-type: none"> • M8 flat washers (2 quantity) • M8 coil washers (2 quantity) 	

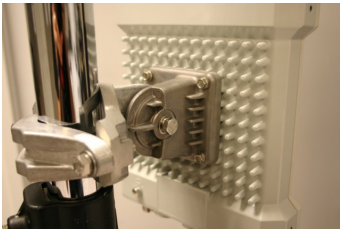
	<p>Attach the mounting bracket to the pole/mast. The mounting bracket is designed to attach to poles with diameters in the range of 2 in. (50mm) to 3in. (75mm).</p>	
3	<p>Complete the AP mounting assembly by attaching the included:</p> <ul style="list-style-type: none"> • 8mm hex cap bolt (one quantity) <p>Through the AP's attached mounting bracket and pole mount. Now the AP may be adjusted to the desired position and tightened with a 1/2-inch spanner wrench to 11 lb/ft (14Nm).</p>	

PMP 450 SM (except PMP 450 SM - 900 MHz)

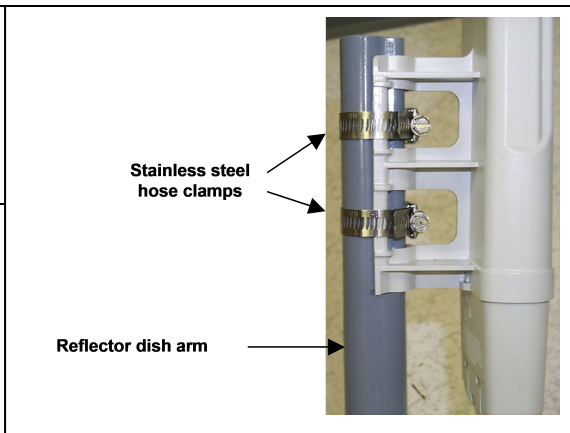
1	<p>Use stainless steel hose clamps for the attachment.</p>	 <p>Stainless steel hose clamps</p> <p>Reflector dish arm</p>
2	<p>Attach the mounting bracket to the structure. Tighten the locking nut.</p>	

PMP 450 SM 900 MHz (Connectorized)

The PMP 450 900 MHz connectorized SM mounting procedure is different from other radios. It does not get directly mounted on pole.

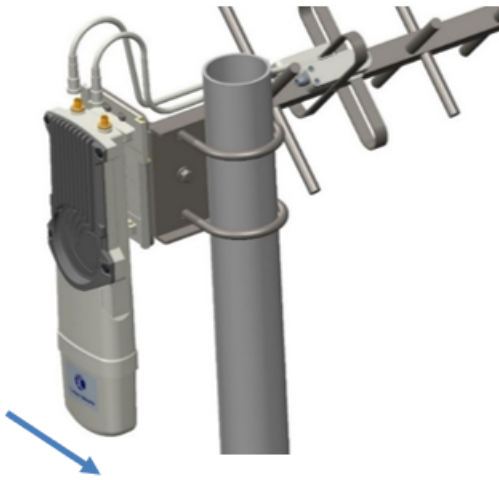
1	Align the 900 MHz SM to E bracket of Yagi antenna	
2	Slide the radio towards right to lock on the antenna	

Mount the top LPU

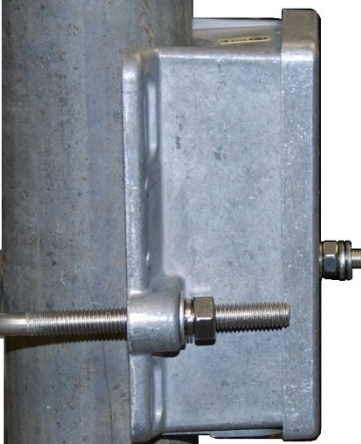
1	<p>For separate LPU mounting, use the U-bolt bracket from the LPU kit to mount the top LPU on the pole below the ODU. Tighten to a torque setting of 7.0 Nm (5.2 lb ft).</p> <p>Please refer Gigabit LPU and Grounding Kit Installation Guide for more details.</p>	
---	---	---





Mount the Surge Suppressor

PMP/PTP 450i/450b Series

Gigabit Ethernet Surge Suppressors are installed at both ends of the drop cable. One within 600 mm (24") of and under the ODU. The other located within 600 mm (24") of the building entry point.

Quick procedure:

The quick procedure for the Surge Suppressor for PMP/PTP 450i/450b Series mounting is as follows:

1	<p>Ground using the terminal on the back of the units. Use the supplied Tubular Lug and 6 mm² (10 AWG) stranded cable, max length 600 mm (24”).</p> <ul style="list-style-type: none"> • Waterproof the cable lug with heat shrink sleeving. • Secure the Cable assembly to the unit using the supplied screw and washer. 	
2	<p>Mount the Gigabit Ethernet Surge Suppressor on the wall or pole</p>	
3	<p>Connect the two CAT5e cables to the Gigabit Ethernet Surge Suppressor</p>	
4	<p>Slide the end cap over the bottom of the Gigabit Ethernet Surge Suppressor, ensuring it clicks firmly in place</p>	

Refer to the Gigabit Ethernet Surge Suppressor Installation Guide for more details.

Figure 108: Gigabit Ethernet Surge Suppressor



PMP/PTP 450 Series

The PMP/PTP 450 Series uses 600SSH Surge Suppressor. The inside of the surge suppressor is shown in [Installation](#).



Caution

The PMP 450 SM 900 MHz is based off of the 450 Series, be sure to use a 600SS to protect this radio type.

Figure 109: 600SSH Surge Suppressor – inside

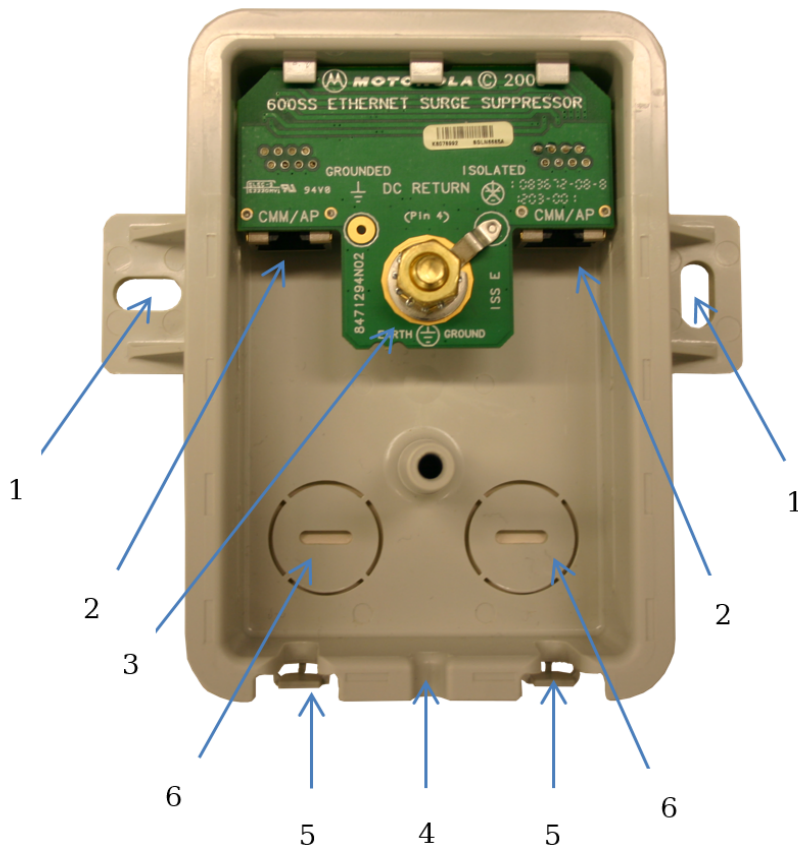

Key to Callouts 600SSH	
1	Holes—for mounting the Surge Suppressor to a flat surface (such as an outside wall). The distance between centers is 4.25 inches (108 mm).
2	RJ-45 connectors—One side (neither side is better than the other for this purpose) connects to the product (AP, SM, AC Adapter, or cluster management module). The other connects to the drop cable.
3	Ground post and washer—use heavy gauge (10 AWG or 6 mm ²) copper wire for connection. Refer to local electrical codes for exact specifications.
4	Ground Cable Opening—route the 10 AWG (6 mm ²) ground cable through this opening.
5	CAT-5 Cable Knockouts—route the two CAT-5 cables through these openings, or alternatively through the Conduit Knockouts.
6	Conduit Knockouts—on the back of the case, near the bottom. Available for installations where cable is routed through building conduit.



Note

The 600SSH surge suppressor is shipped in the “isolated” position (pin 4 isolated by 68V from protective earth). If packet error issues occur over the Ethernet link (verify by pinging the device through the 600SSH), configure the 600SSH to “grounded” position (by moving the 600SSH switch from “isolated” to “ground”) to avoid ground loops that may be present in the system.

The mounting procedure for the Surge Suppressor for PMP/PTP 450 Series is as follows:

1	Remove the cover of the 600SSH Surge Suppressor.
2	With the cable openings facing downward, mount the 600SSH to the outside of the subscriber premises, as close to the point where the Ethernet cable penetrates the residence or building as possible, and as close to the grounding system (Protective Earth) as possible.
3	Wrap an AWG 10 (or 6mm ²) copper wire around the Ground post of the 600SSH.
4	Tighten the Ground post locking nut in the 600SSH onto the copper wire.
5	Securely connect the copper wire to the grounding system (Protective Earth) according to applicable regulations.
6	Using diagonal cutters or long nose pliers, remove the knockouts that cover the cable openings to the 600SSH.
7	Pack both surge suppressor Ethernet jacks with dielectric grease.
8	Wrap a splice loop in the loose end of the Ethernet cable from the SM.
9	Connect that cable to one of the Ethernet jacks.
10	Connect an Ethernet cable to the other Ethernet jack of the 600SSH and to the power adapter.
11	Replace the cover of the 600SSH.

General protection installation

To adequately protect a 450 Platform Family installation, both ground bonding and transient voltage surge suppression are required.

Grounding cable requirements

When routing, fastening and connecting grounding cables, the following requirements must be implemented:

- Grounding conductors must be run as short, straight, and smoothly as possible, with the fewest possible number of bends and curves.
- Grounding cables must not be installed with drip loops.

- All bends must have a minimum radius of 203 mm (8 in) and a minimum angle of 90° ([Installation](#)). A diagonal run is preferable to a bend, even though it does not follow the contour or run parallel to the supporting structure.
- All bends, curves and connections must be routed towards the grounding electrode system, ground rod, or ground bar.
- Grounding conductors must be securely fastened.
- Braided grounding conductors must not be used.
- Approved bonding techniques must be used for the connection of dissimilar metals.

Figure 110: Grounding cable minimum bend radius and angle

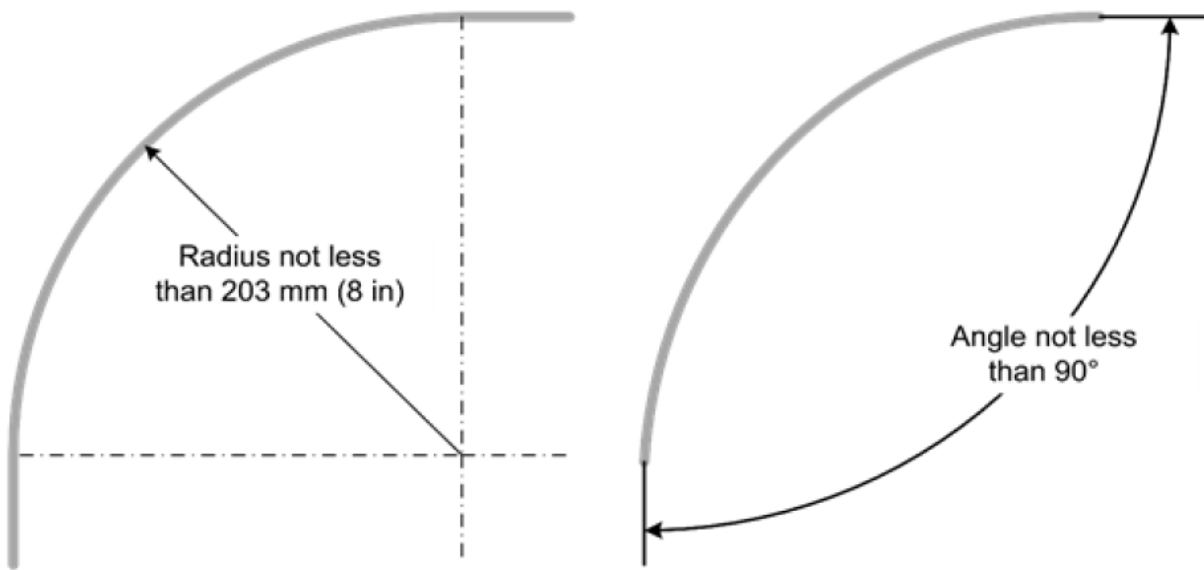

Caution

Do not attach grounding cables to the ODU mounting bracket bolts, as this arrangement will not provide full protection.

Basic requirements

The following basic protection requirements must be implemented:

- ODU must be in 'Zone B' (see [Lightning protection zones](#)).
- ODU must be grounded to the supporting structure.
- A surge suppression unit must be installed on the outside of the building.

- The distance between the ODU and Gigabit Surge Suppressor should be kept to a minimum.
- The drop cable must not be laid alongside a lightning air terminal.
- All grounding cables must be a minimum size of 10 mm² csa (8AWG), preferably 16 mm² csa (6AWG), or 25 mm² csa (4AWG).

Protection requirements for a wall installation

If the ODU is to be mounted on the wall of a building, then in addition to the general protection requirements (above), the following requirements must be observed:

- The equipment must be lower than the top of the building or its lightning air terminal.
- The building must be correctly grounded.

Schematic examples of wall installations are shown in [Installation](#).

Figure 111: Grounding and lightning protection on wall

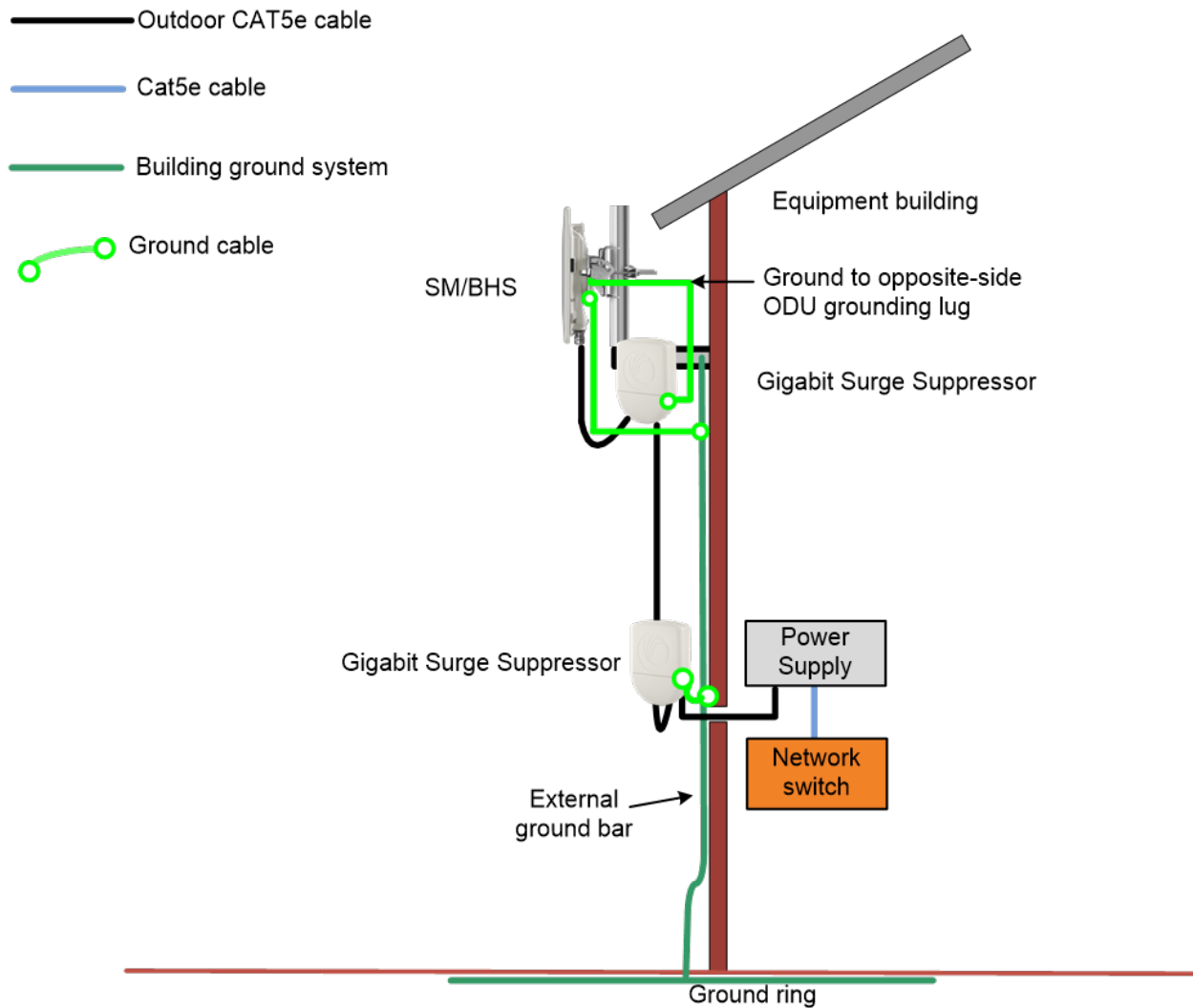

Protection requirements for a mast or tower installation

If the ODU is to be mounted on a metal tower or mast, then in addition to the general protection requirements (above), the following requirements must be observed:

- The equipment must be lower than the top of the tower or its lightning air terminal.
- The metal tower or mast must be correctly grounded.

Schematic examples of mast or tower installations are shown in [Installation](#).

Figure 112: Grounding and lightning protection on mast or tower

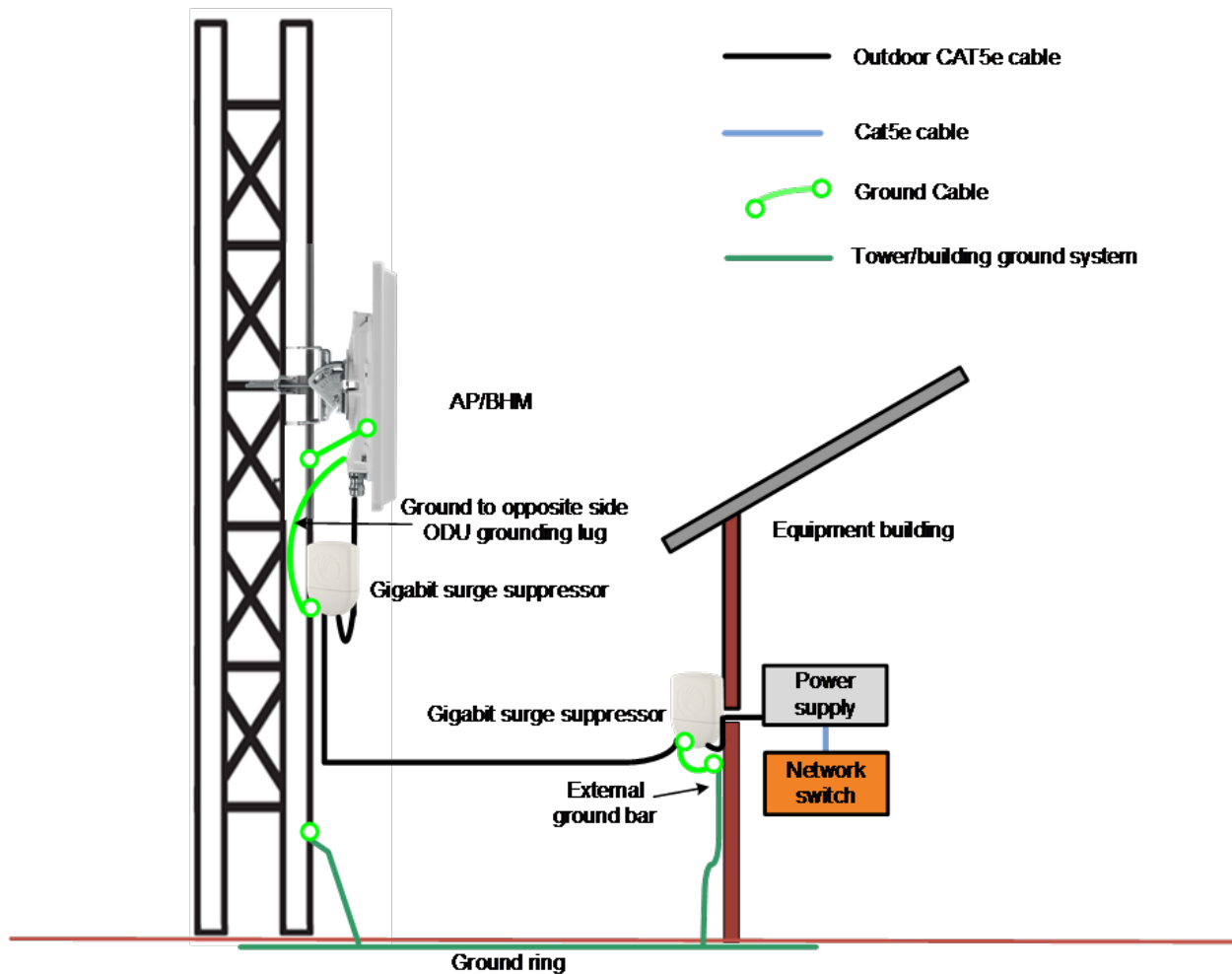

Protection requirements on a multi-floor building

If the ODU is to be mounted on a high-rise building, it is likely that cable entry is at roof level ([Roof installation](#)) and the equipment room is several floors below. The following additional requirements must be observed:

- The ODU must be below the lightning terminals and finials.
- A grounding conductor must be installed around the roof perimeter to form the main roof perimeter lightning protection ring.
- Air terminals are typically installed along the length of the main roof perimeter lightning protection ring typically every 6.1m (20ft).
- The main roof perimeter lightning protection ring must contain at least two down conductors

connected to the grounding electrode system. The down conductors should be physically separated from one another, as far as practical.

Figure 113: Grounding and lightning protection on building

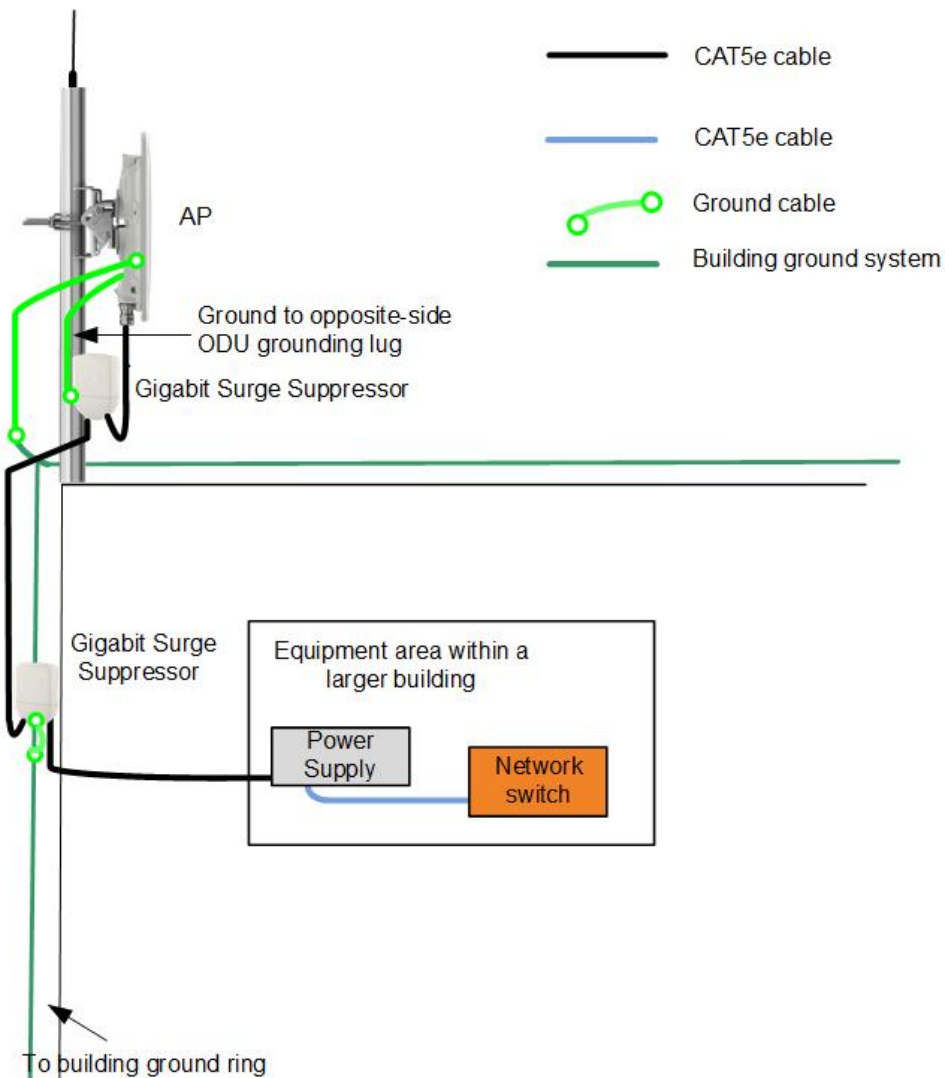

Installing the copper Cat5e Ethernet interface

To install the copper Cat5e Ethernet interface, use the following procedures:

- [Install the main drop cable](#)
- [Install the bottom LPU to PSU drop cable](#)
- Installing external antennas to a connectorized ODU



Caution

To avoid damage to the installation, do not connect or disconnect the drop cable when power is applied to the PSU or network terminating equipment.



Caution

Always use Cat5e cable that is gel-filled and shielded with copper-plated steel. Alternative types of Cat5e cable are not supported by Cambium Networks. Cambium Networks supply this cable (Cambium part numbers WB3175 and WB3176), RJ45 connectors (Cambium part number WB3177) and a crimp tool (Cambium part number WB3211). The LPU and grounding kit contains a 600-mm length of this cable.

Install the main drop cable



Warning

The metal screen of the drop cable is very sharp and may cause personal injury.

- ALWAYS wear cut-resistant gloves (check the label to ensure they are cut resistant).
- ALWAYS wear protective eyewear.
- ALWAYS use a rotary blade tool to strip the cable (DO NOT use a bladed knife).



Warning

Failure to obey the following precautions may result in injury or death:

- Use the proper hoisting grip for the cable being installed. If the wrong hoisting grip is used, slippage or insufficient gripping strength will result.
- Do not reuse hoisting grips. Used grips may have lost elasticity, stretched, or become weakened. Reusing a grip can cause the cable to slip, break, or fall.
- The minimum requirement is one hoisting grip for each 60 m (200 ft) of cable.

Cut to length and fit hoisting grips

1	Cut the main drop cable to length from the top LPU to the bottom LPU.
2	Slide one or more hoisting grips onto the top end of the drop cable.
3	Secure the hoisting grip to the cable using a special tool, as recommended by the manufacturer.

Terminate with RJ45 connectors



Caution

Check that the crimp tool matches the RJ45 connector, otherwise the cable or connector may be damaged.

1	Strip the cable outer sheath and fit the RJ45 connector load bar.
2	Fit the RJ45 connector housing as shown. To ensure there is effective strain relief, locate the cable inner sheath under the connector housing tang.

Figure 114: RJ45 connector and cable color code

Pin	Color (Supplied cable)	Color (Conventional)	Pins on plug face
1	Light Orange	White/Orange	
2	Orange	Orange	
3	Light Green	White/Green	
4	Blue	Blue	
5	Light Blue	White/Blue	
6	Green	Green	
7	Light Brown	White/Brown	
8	Brown	Brown	

Figure 115: RJ45 cable



Install the bottom LPU to PSU drop cable

Install the bottom LPU

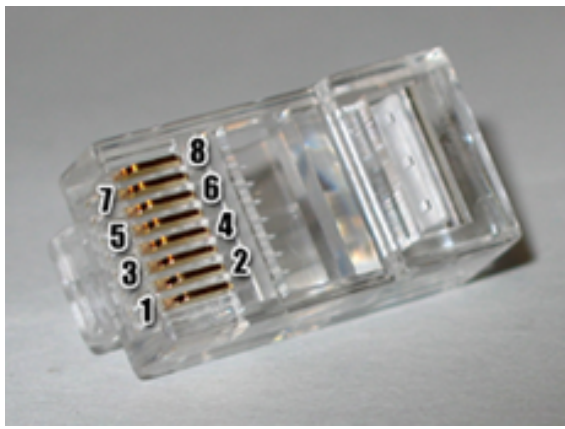
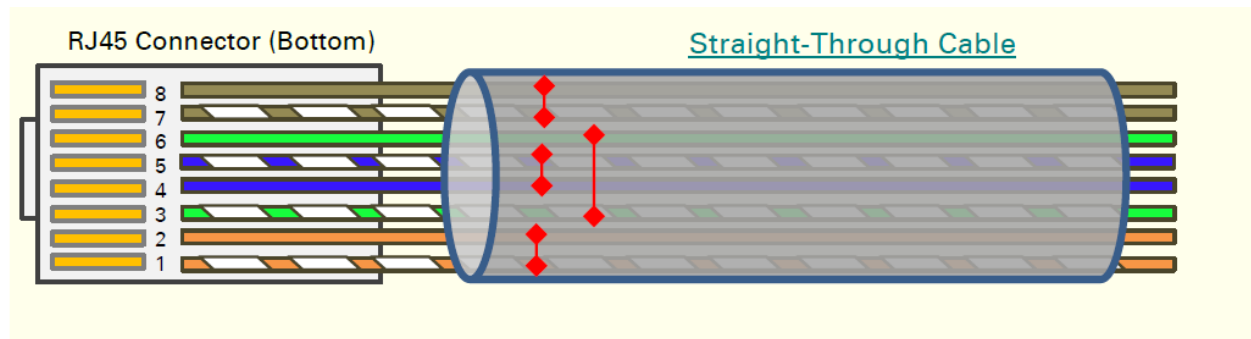
Install the bottom LPU, ground it, and connect it to the main drop cable.

1	Select a mounting point for the bottom LPU within 600 mm (24 in) of the building entry point. Mount the LPU vertically with cable glands facing downwards.
---	--

	<p> Power over Ethernet CAT5e cable (gel-filled, shielded with copper-plated steel) Network CAT5e cable Ground cables Site grounding system </p> <p> Bottom LPU Maximum 600 mm (24 inches) PSU drop cable Building entry point AC supply PSU Network terminating equipment LPU to grounding system Grounding system </p>
2	Connect the main drop cable using the EMC cable gland to the bottom LPU.
3	<p>Fasten one ground cable to the bottom LPU using the M6 (small) lug. Tighten both nuts to a torque of 5 Nm (3.9 lb ft):</p> <p> Locking nut Washer M6 lug Washer Nut Toothed washer Other end of ground cable has M10 lug to ground </p>
4	Select a building grounding point near the LPU bracket. Remove paint from the surface and apply anti-oxidant compound. Fasten the LPU ground cable using the M10 (large) lug.

Install the LPU to PSU drop cable

Use this procedure to terminate the bottom LPU to PSU drop cable with RJ45 connectors at both ends, and with a cable gland at the LPU end.



Warning

The metal screen of the drop cable is very sharp and may cause personal injury. ALWAYS wear cut-resistant gloves (check the label to ensure they are cut resistant). ALWAYS wear protective eyewear. ALWAYS use a rotary blade tool to strip the cable, not a bladed knife.



Caution

Check that the crimp tool matches the RJ45 connector, otherwise the cable or connector may be damaged.

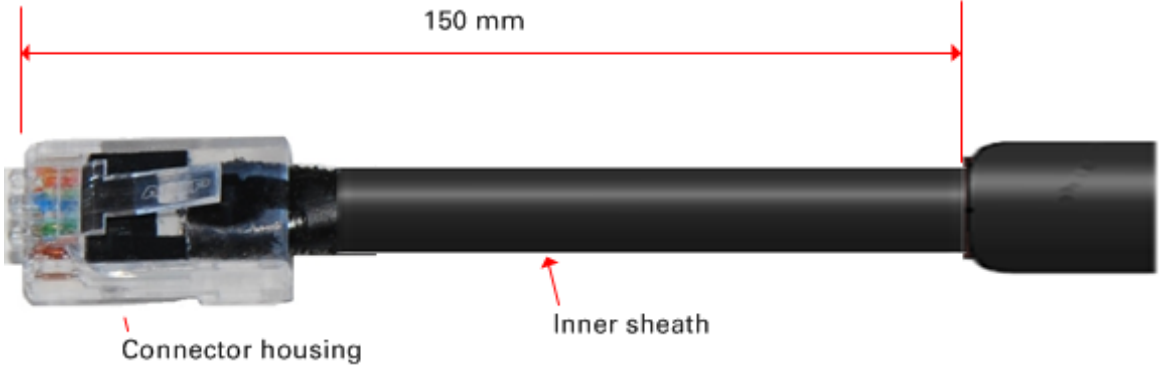
1	Cut the drop cable to the length required from bottom LPU to PSU.
2	At the LPU end only: <ul style="list-style-type: none">• Fit one cable gland and one RJ45 connector by following the procedure Terminate with RJ45 connectors.• Connect this cable and gland to the bottom LPU.
3	At the PSU end only: Do not fit a cable gland. Strip the cable outer sheath and fit the RJ45 connector load bar. Fit the RJ45 connector housing. To ensure there is effective strain relief, locate the cable inner sheath under the connector housing tang: 

Installing external antennas to a connectorized ODU

PMP 450i Series

To mount and connect an external antenna to the connectorized ODU, proceed as follows:

1	Mount the antenna(s) according to manufacturer's instructions.
2	Connect the ODU A and B interfaces to the antenna(s) with RF cable of type LMR-400 (Cambium part numbers 30010194001 and 30010195001) and N type connectors (Cambium part number 09010091001). Tighten the N type connectors to a torque setting of 1.7 Nm (1.3 lb ft).
3	If the ODU is mounted indoors, install lightning arrestors at the building entry point:
4	Form drip loops near the lower ends of the antenna cables. These ensure that water is not channeled towards the connectors.

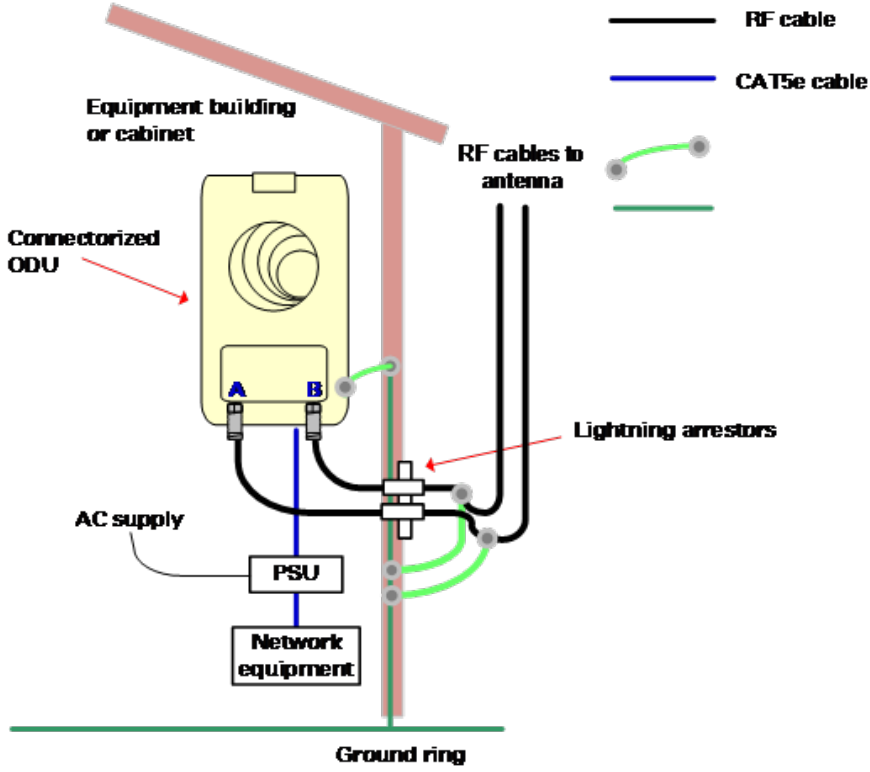
5	If the ODU is mounted outdoors, weatherproof the N type connectors (when antenna alignment is complete) using PVC tape and self-amalgamating rubber tape.
6	<p>Weatherproof the antenna connectors in the same way (unless the antenna manufacturer specifies a different method).</p> 
7	Ground the antenna cables to the supporting structure within 0.3 meters (1 foot) of the ODU and antennas using the Cambium grounding kit (part number 01010419001):

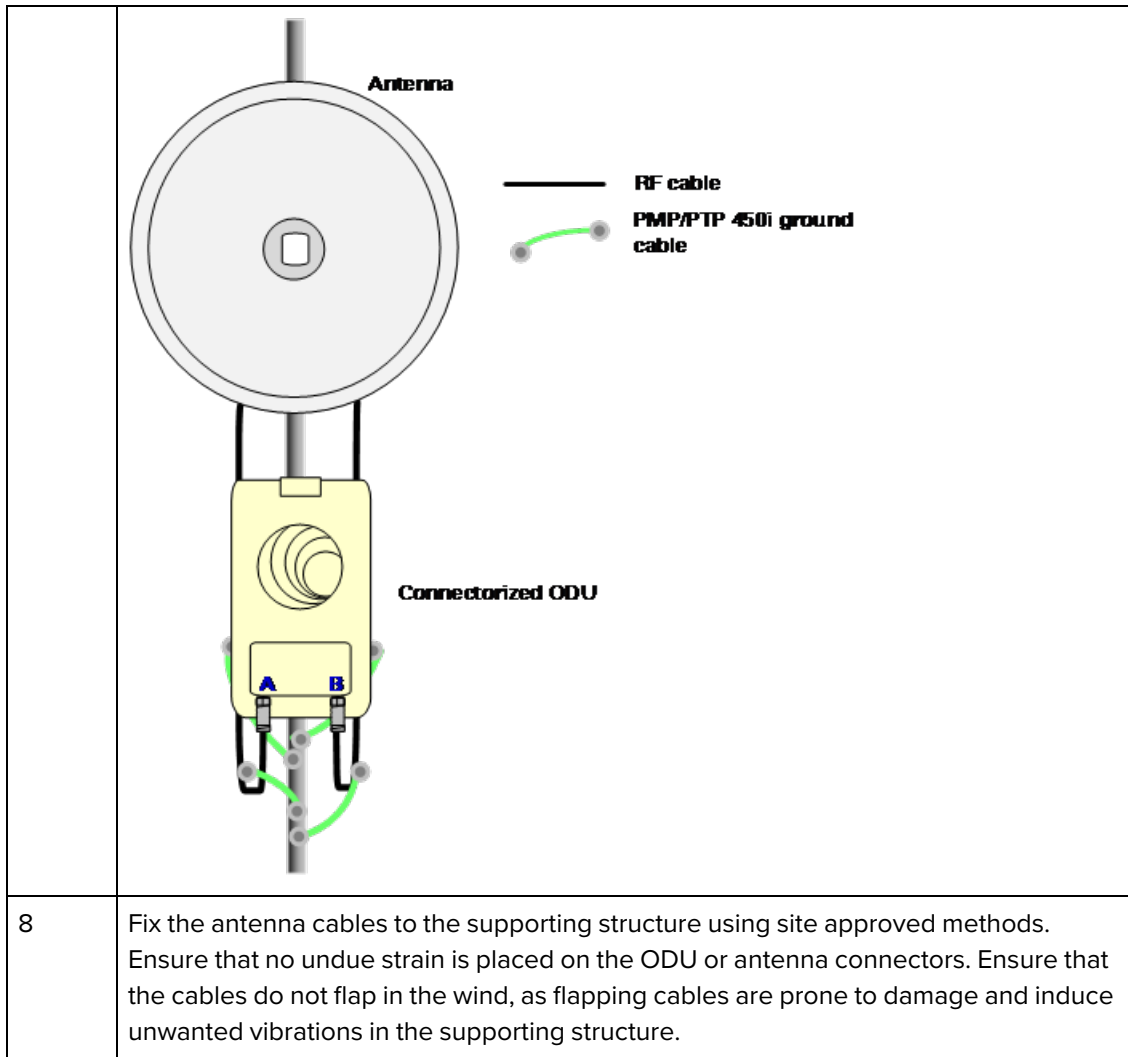

Note
 A video on weatherproofing procedure can be found at: <https://www.youtube.com/watch?v=a-twPfcVq4A>

Assembling the PMP 450i AP 5 GHz sector antenna and attaching to the radio

To assemble a PMP 450i Series AP antenna, perform the following steps.



Note
 Cambium recommends assembling the antenna, attach the AP and cabling, and to seal the RF connections before installing the unit at the deployment site.

1. Inventory the parts to ensure that you have them all before you begin. The full set of parts is shown below.

Figure 116: AP antenna parts



2. Remove top plate from the antenna as shown in [Antenna top plate](#).

Figure 117: Antenna top plate

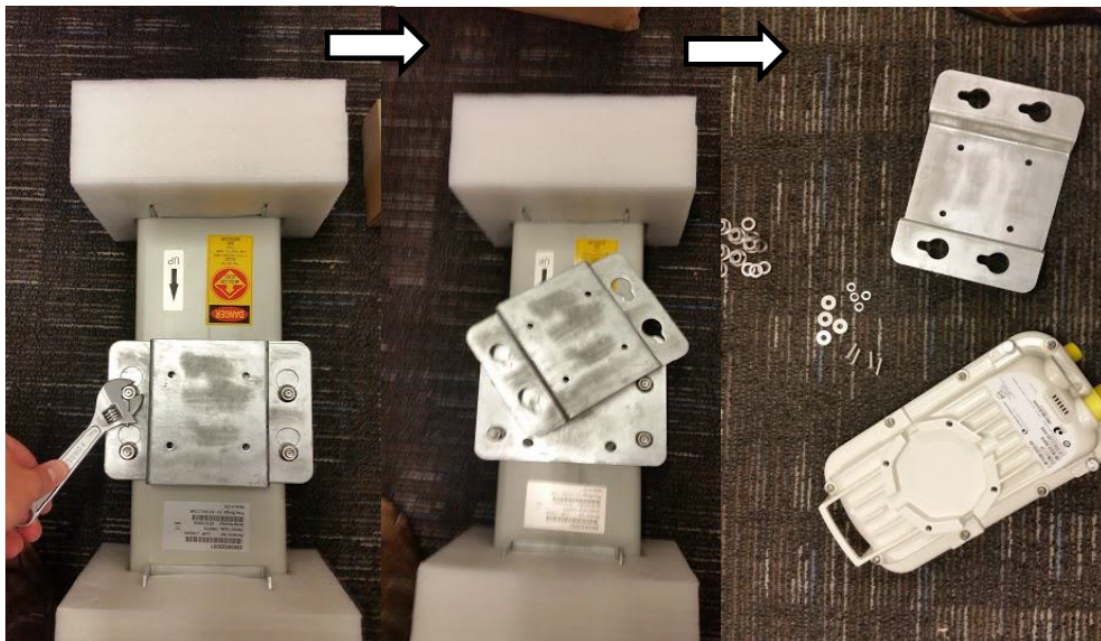

3. Attach the antenna plate to the AP as shown in [Attaching antenna plate to the AP](#).



Note

Please use the four “thin neck” M6 bolts and split washers provided with the connectorized units rather than the ones provided in the antenna kit.

Figure 118: Attaching antenna plate to the AP

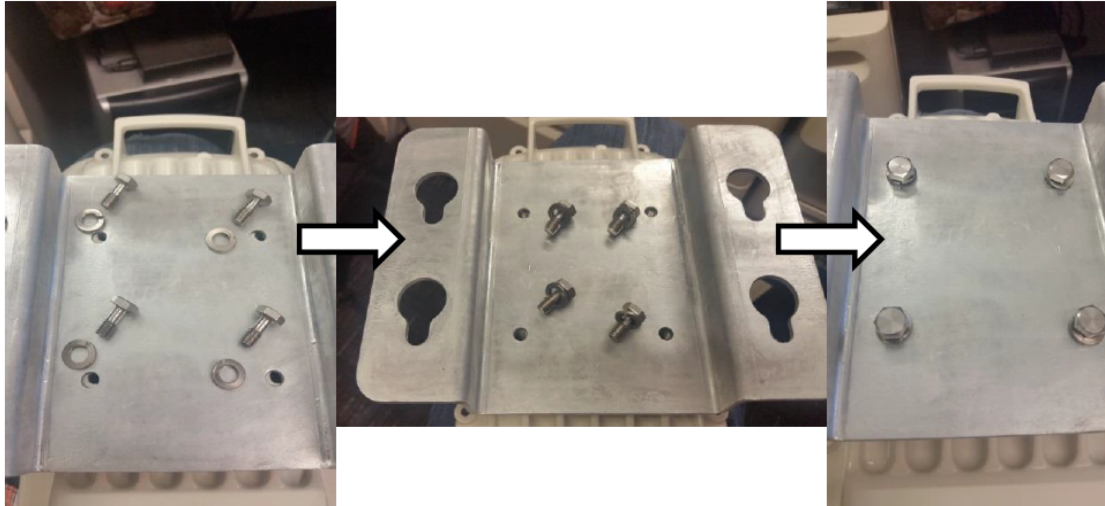

4. Attach the plate mounted AP to the antenna and tighten the (4) serrated flange nuts using a spanner wrench

Figure 119: Attaching the plate

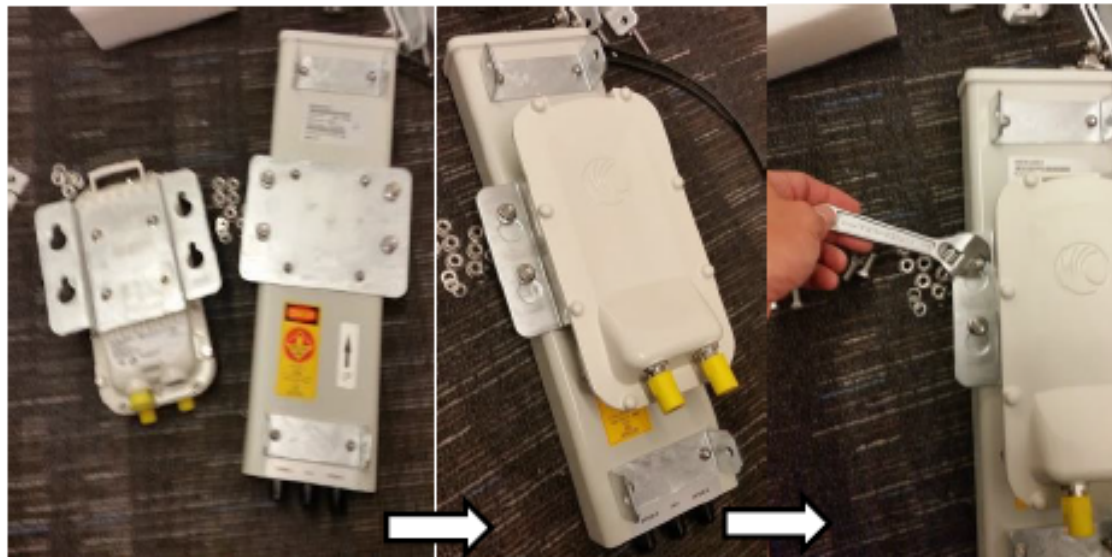

5. Connect the port A of AP to vertical and port B of AP to horizontal polarization interfaces of the antenna with RF cable. Tighten the N type connectors to a torque setting of 1.7 Nm (1.3 lb ft).

Figure 120: Connect the port A and B to the PMP 450i AP

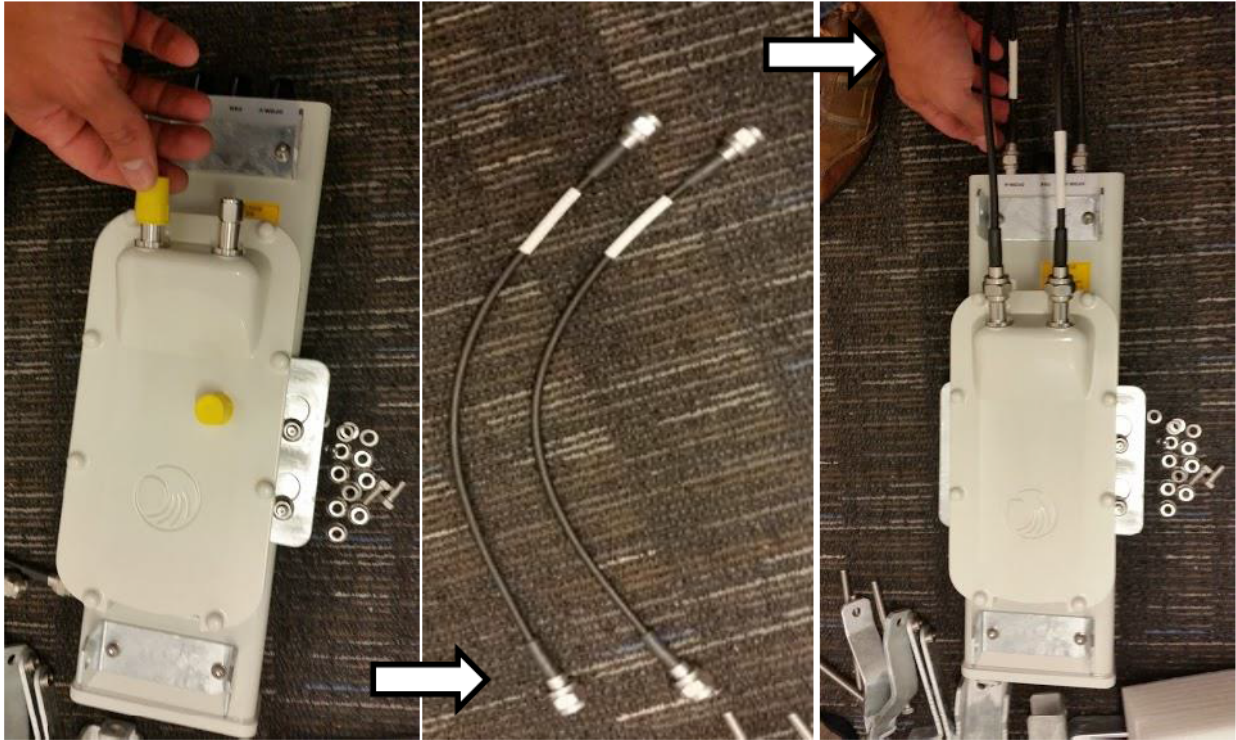

6. Assemble the upper bracket by attaching the (2) 7" hex bolts to the bracket using (2) serrated flange nuts

Figure 121: AP antenna upper bracket assembly

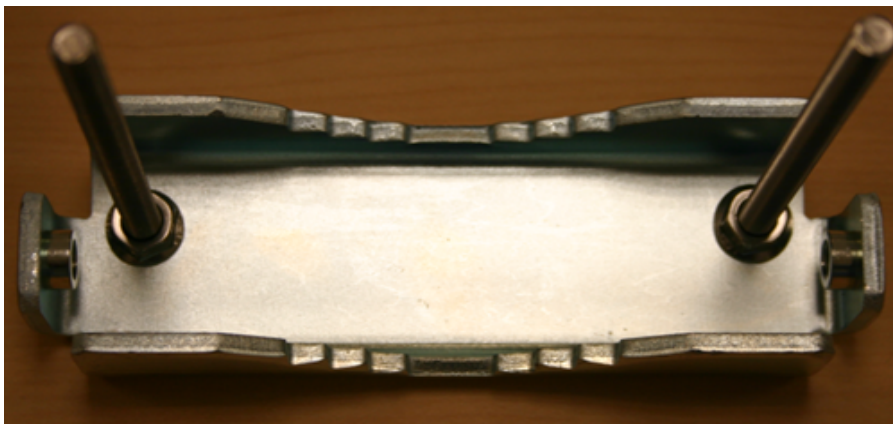

7. Attach the upper bracket to the adjustment arms using (2) hex bolts, (2) flat washers and (2) lock washers. Feed the bolt through the lock washer then flat washer, then thread the bolt into the upper bracket's threaded receptacle.

Figure 122: AP antenna upper bracket attached to upper adjustment arms



8. Attach the rear strap to the upper bracket using (2) serrated flange nuts and (1) retaining bracket. Do not tighten the nuts now.

Figure 123: Rear strap connected to upper AP antenna bracket

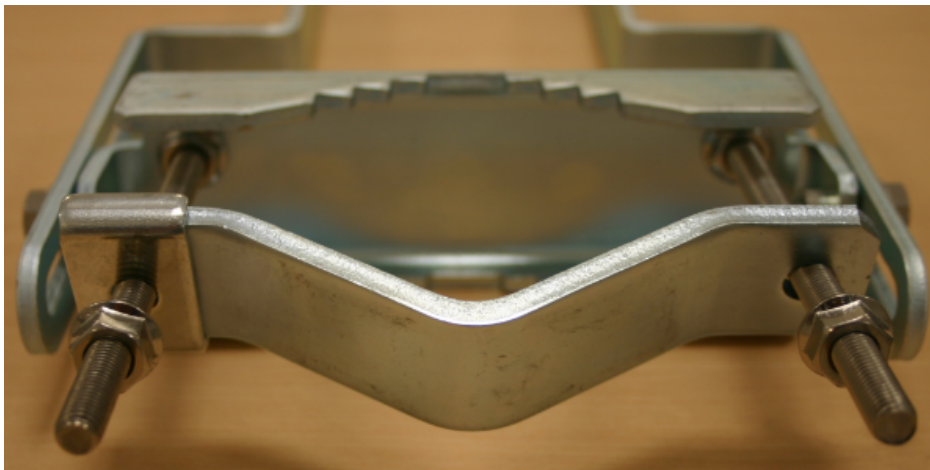

9. Attach the entire upper bracket to the antenna using (2) hex bolts, (2) flat washers and (2) lock washers. Feed the bolt through the lock washer then flat washer, then thread the bolt into the upper bracket's threaded receptacle.

Figure 124: Assembled upper bracket connected to AP antenna



10. Begin assembling the lower bracket by attaching the (2) 7" hex bolts to the bracket using (2) serrated flange nuts

Figure 125: AP Antenna Lower Bracket Assembly



11. Attach the rear strap to the bracket using (2) serrated flange nuts and (1) retaining bracket. Do not tighten the nuts now. Attach the entire lower bracket to the antenna using (2) hex bolts, (2) flat washers and (2) lock washers.

Figure 126: Lower bracket attached to AP antenna



Figure 127: Completed AP and antenna assembly



PMP 450 Series

Assembling the PMP 450 AP antenna

To assemble a PMP 450 Series AP antenna, perform the following steps.



Note

Cambium recommends assembling the antenna, attach the AP and cabling, and to seal the RF connections before installing the unit at the deployment site.

1	Inventory the parts to ensure that you have them all before you begin. The full set of parts is shown below. Figure 128: PMP 450 AP antenna parts
---	--

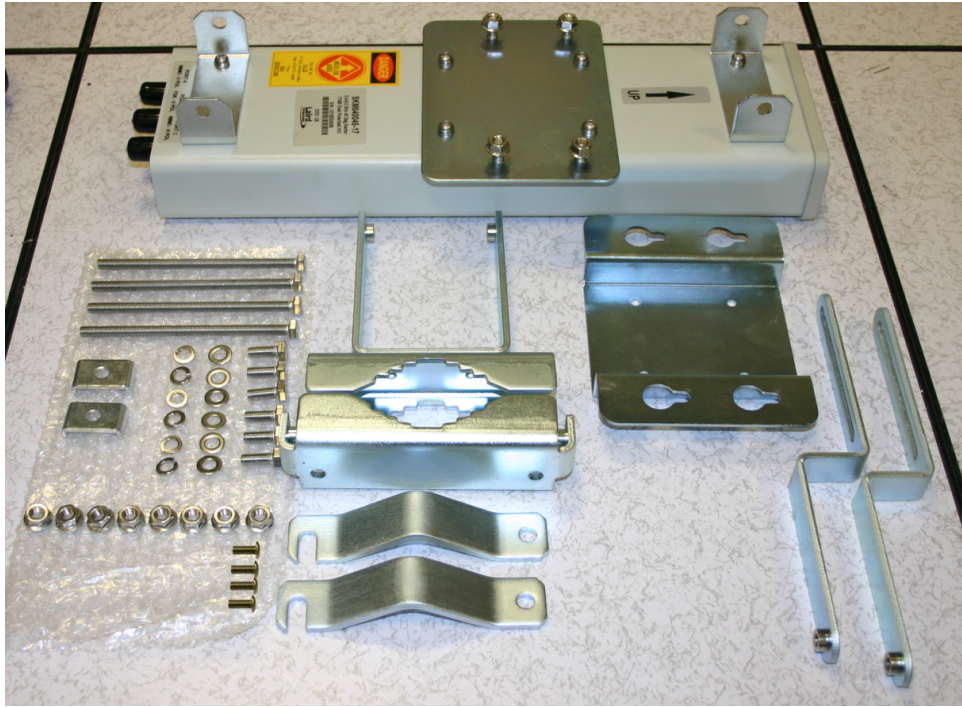

- 2 Begin assembling the upper bracket by attaching the (2) 7" hex bolts to the bracket using (2) serrated flange nuts

Figure 129: AP antenna upper bracket assembly

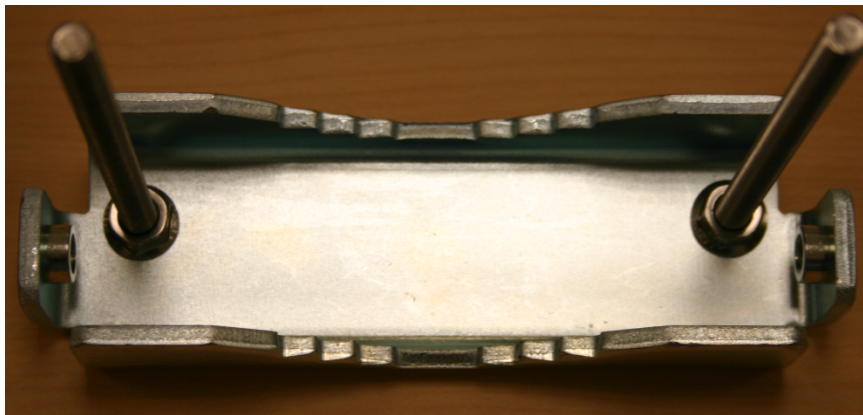

- 3 Attach the upper bracket to the adjustment arms using (2) hex bolts, (2) flat washers and (2) lock washers. Feed the bolt through the lock washer then flat washer, then thread the bolt into the upper bracket's threaded receptacle.

Figure 130: AP antenna upper bracket attached to upper adjustment arms

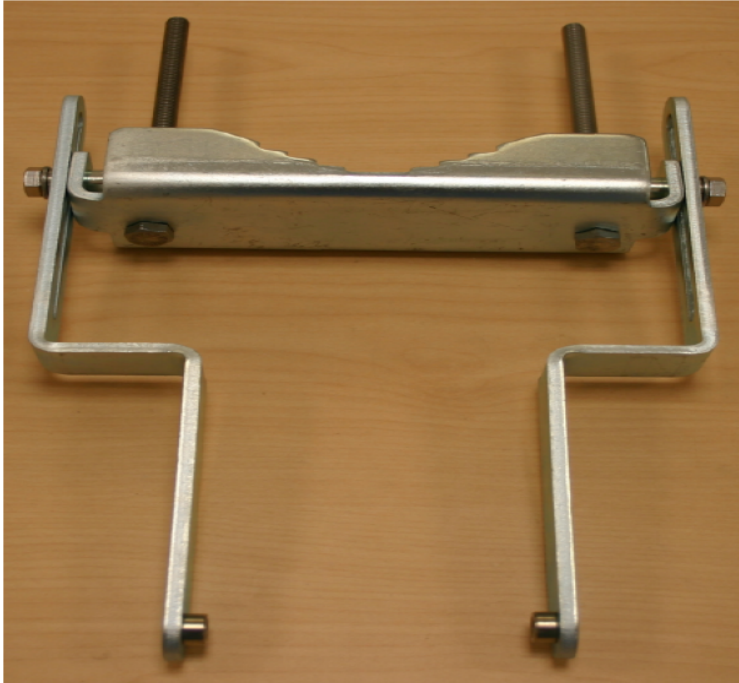

- 4 Attach the rear strap to the upper bracket using (2) serrated flange nuts and (1) retaining bracket. Do not tighten the nuts now.

Figure 131: Rear strap connected to upper AP antenna bracket

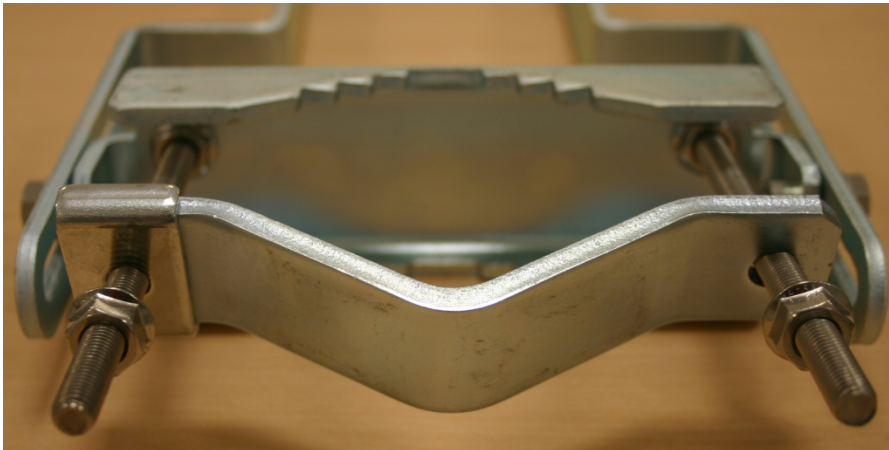

- 5 Attach the entire upper bracket to the antenna using (2) hex bolts, (2) flat washers and (2) lock washers. Feed the bolt through the lock washer then flat washer, then thread the bolt into the upper bracket's threaded receptacle.

Figure 132: Assembled upper bracket connected to AP antenna



Note

Use shielded cable for all infrastructure connections associated with APs, SMs, and CMMs. The environment that these modules operate in often has significant unknown or varying RF energy. Operator experience consistently indicates that the additional cost of shielded cables is more than compensated by predictable operation and reduced costs for troubleshooting and support.

- 6 Begin assembling the lower bracket by attaching the (2) 7" hex bolts to the bracket using (2) serrated flange nuts.

Figure 133: AP Antenna Lower Bracket Assembly



- 7 Attach the rear strap to the bracket using (2) serrated flange nuts and (1) retaining bracket. Do not tighten the nuts now.
- Attach the entire lower bracket to the antenna using (2) hex bolts, (2) flat washers and (2) lock washers.

Figure 134: Lower bracket attached to AP antenna



Attaching the PMP 450 AP to the antenna

To attach a PMP 450 Series AP to the antenna, perform the following steps.



Note

Use shielded cable for all infrastructure connections associated with APs, SMs, and CMMs. The environment that these modules operate in often has significant unknown or varying RF energy. Operator experience consistently indicates that the additional cost of shielded cables is more than compensated by predictable operation and reduced costs for troubleshooting and support.

- 1 Attach the included bracket to the rear of the AP using the (4) M5 x 7mm bolts

Figure 135: Attaching bracket to the rear of the AP



- 2 Attach the AP to the antenna by sliding the bracket onto the bolts and tighten the (4) serrated flange nuts using a 13-mm spanner wrench.

Figure 136: Lower bracket attached to AP antenna



Note

If using a non-standard antenna, do not cover the equilibrium membrane vent located on the back of the unit

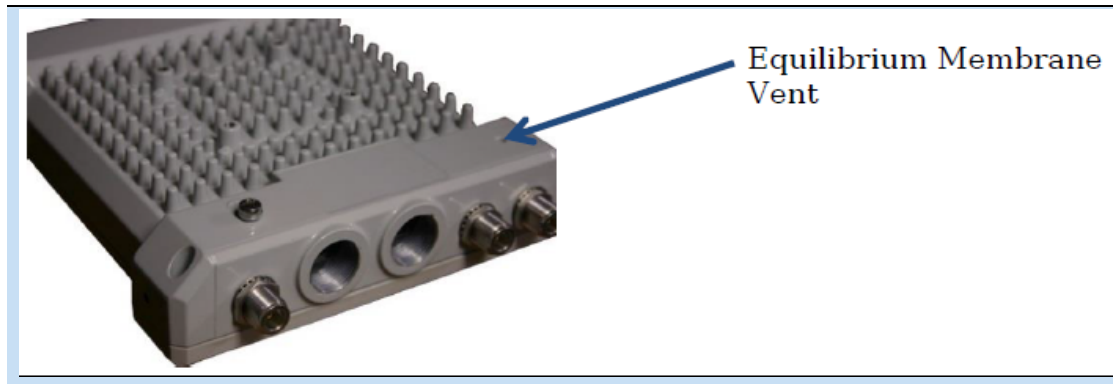





Figure 137: Mounted PMP 450 AP and antenna assembly, viewed from back and back



Attaching the PMP 450 Series AP and antenna to the mount point

- | | |
|---|--|
| 1 | Attach the upper bracket of the antenna to the mount point by closing the rear strap around the pole and tightening the (2) serrated flange nuts using a 13mm spanner wrench. These must be tightened evenly on the pole to avoid jumping/stripping threads. |
|---|--|

Figure 138: Attaching the AP antenna upper bracket to the pole

	
2	<p>Attach the lower bracket of the antenna to the mount point by closing the rear strap around the pole and tightening the (2) serrated flange nuts using a 13mm spanner wrench. These must be tightened evenly on the pole to avoid jumping/stripping threads.</p> <p><i>Figure 139: Attaching the AP antenna lower bracket to the pole</i></p> 
3	<p>Use a local map, compass, and/or GPS device as needed to determine the direction that one or more APs require to each cover the 90° sector.</p>
4	<p>Choose the best mounting location for your particular application.</p> <div style="border: 1px solid black; background-color: #e1f5fe; padding: 10px; margin-top: 10px;">  <p>Note</p> <p>Use the embedded spectrum analyzer or a commercial analyzer to evaluate the frequencies present in various locations. OFDM APs need not be mounted next to each other. They can be distributed throughout a given site. However, the 90° offset must be maintained. If you want to collocate these APs with PMP 100 Series APs of the 5.4-GHz frequency band range, plan to allow at least 25 MHz of separation between their center channels.</p> </div>
5	<p>Secure a ground strap to the ground lug on the back of the AP.</p>
6	<p>Secure the ground strap to the pole, tower, or other trusted ground.</p>

7

The bracket of the standard antenna has provision for measured down tilt. The recommended practice is to use one of the many radio analysis and mapping tools or on-line tools to calculate down tilt based on antenna height above the service area.

The proper angle of tilt can be calculated as a factor of both the difference in elevation and the distance that the link spans. Even in this case, a plumb line and a protractor can be helpful to ensure the proper tilt. This tilt is typically minimal.

The number of degrees to offset (from vertical) the mounting hardware leg of the support tube is equal to the angle of elevation from the lower module to the higher module (b in the example provided in [Straight-through Ethernet Cable](#)).

Figure 140: Variables for calculating angle of elevation (and depression)

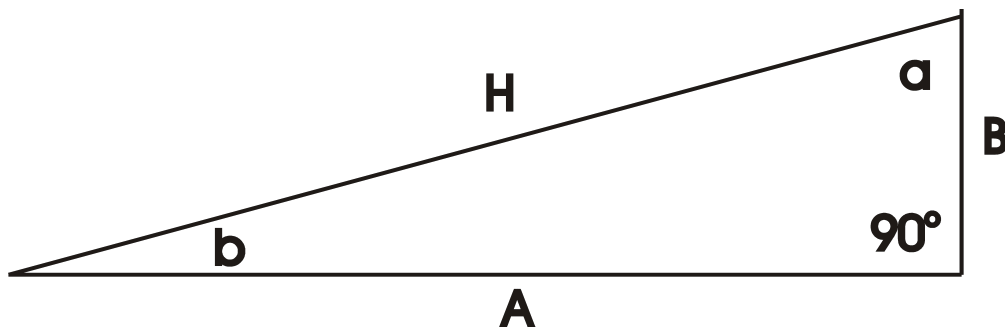

Where:		Is:	
	b		angle of elevation
	B		vertical difference in elevation
	A		horizontal distance between modules

To use metric units to find the angle of elevation, use the following formula:

$$\tan b = \frac{B}{1000A}$$

Where:		Is:	
	B		expressed in meters
	A		expressed in kilometers

To use English standard units to find the angle of elevation, use the following formula:

$$\tan b = \frac{B}{5280A}$$

Where:		Is:	
	B		expressed in feet
	A		expressed in miles

The angle of depression from the higher module is identical to the angle of elevation from the lower module.

- 8 Connect the coax cables to the antenna and to the AP
- 9 Weatherproof the connector on the coax cables (see section [Attaching and weatherproofing an N type connector](#)).

PMP 450i Series AP 900 MHz

Mounting of PMP 450i AP 900 MHz

- 1 Inventory the parts to ensure that you have them all before you begin. The full set of parts is shown in [Installation](#).

Figure 141: PMP 450i AP 900 MHz antenna unbox view

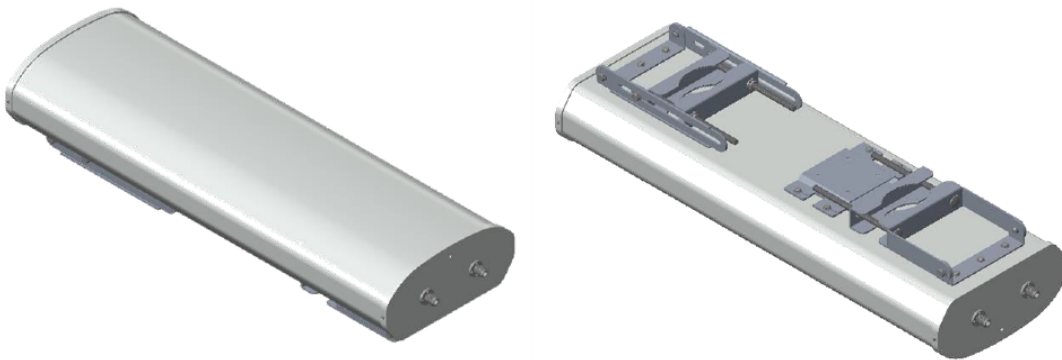
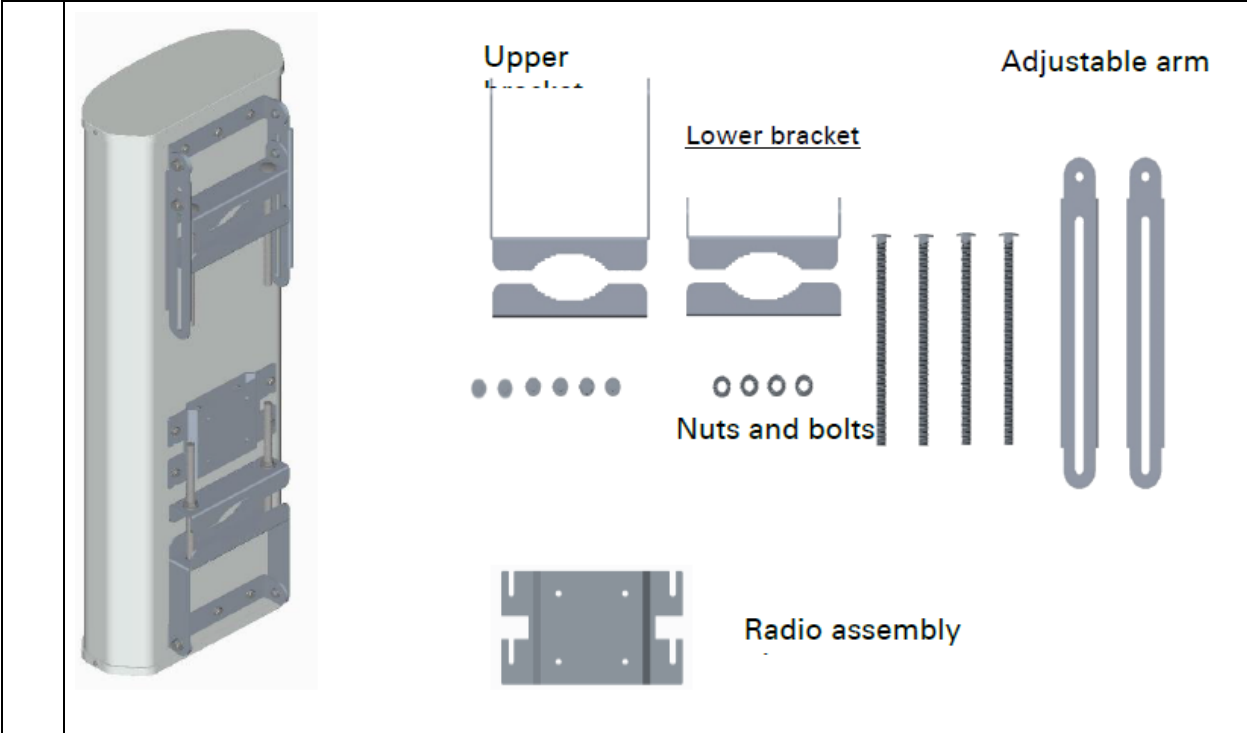
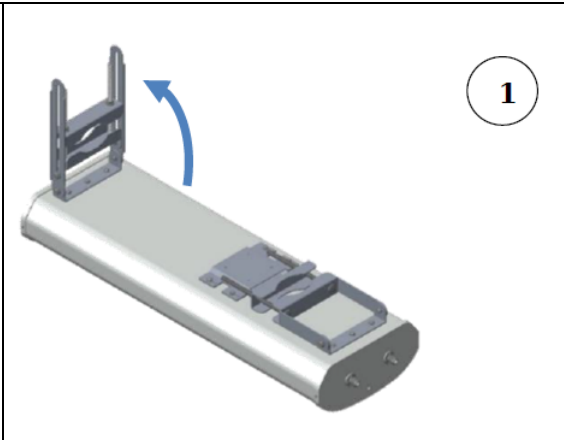
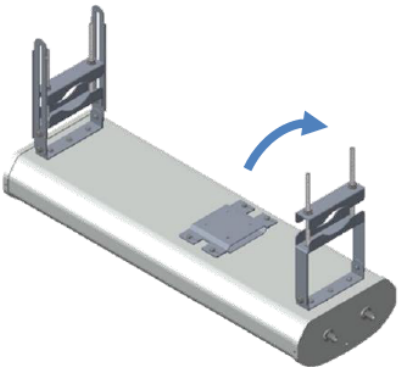
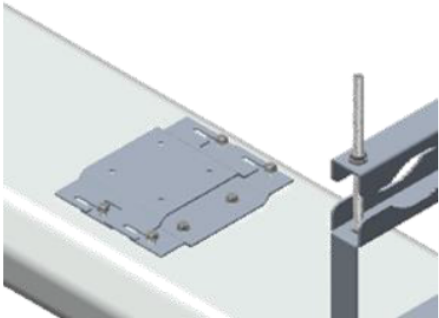
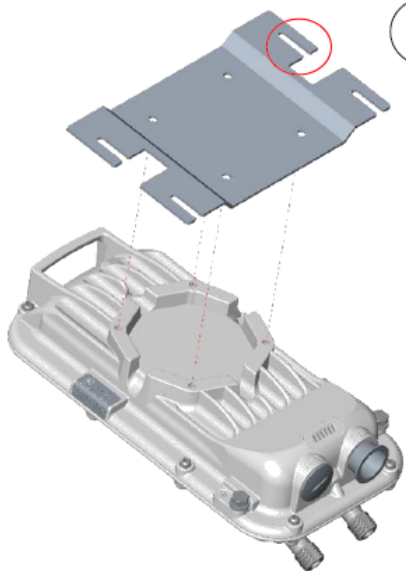

Figure 142: PMP 450i AP 900 MHz antenna inventory



2 (1) Unfold the upper bracket assembly of the antenna.



<p>(2) Unfold the lower bracket assembly.</p>	 <p style="text-align: right;">2</p>
<p>(3) Loose the radio assembly plate by untightening M8 four bolts.</p>	 <p style="text-align: right;">3</p>
<p>(4) Remove the radio assembly top plate by sliding towards upper bracket assembly.</p>	<p>x`</p>
<p>3 (1) Place the radio assembly plate on the radio and align holes with radio enclosure.</p> <div style="border: 1px solid black; padding: 5px; margin-top: 10px;"> <p>Note</p> <p>Ensure that the radio plate notch opening and RF port of radio in same direction. It is also important to make sure you attach the radio assembly plate in the proper orientation as shown in figure.</p> </div>	 <p style="text-align: right;">1</p>

(2) Insert M6 bolts through plate into radio enclosure

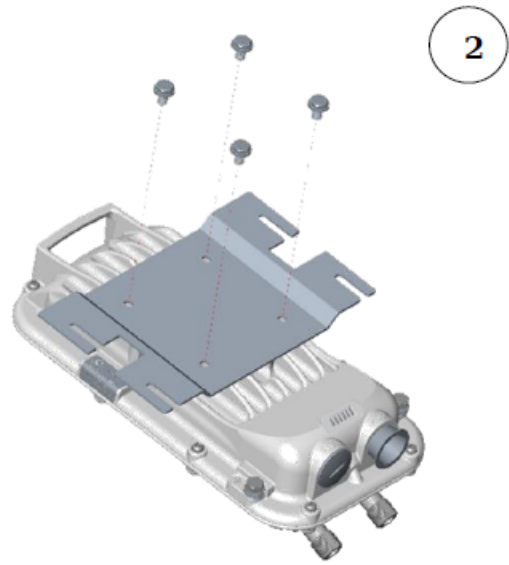

(3) Fix the plate by tightening four bolts with a torque setting on 2 ± 0.5 Nm

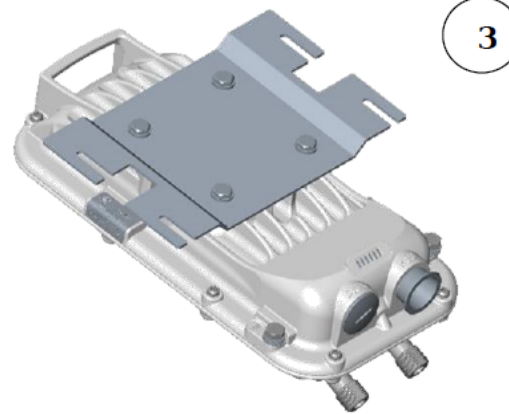

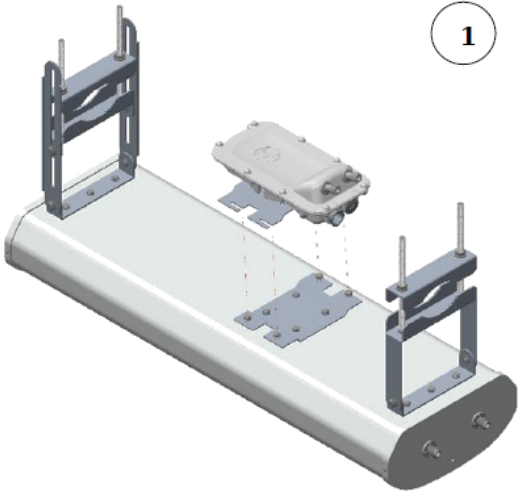
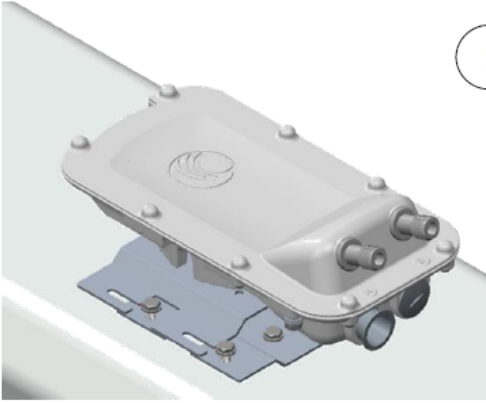
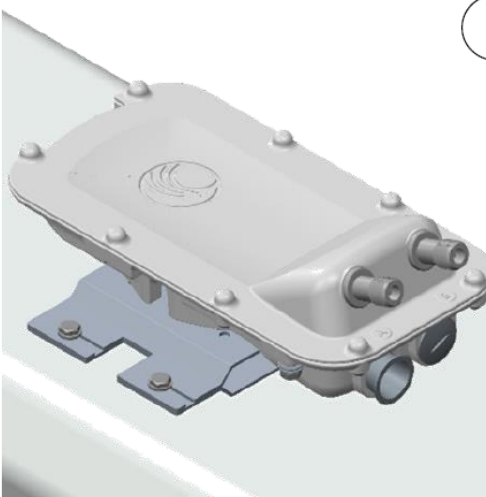
4	<p>(1) Place the radio mounted plate on sector antenna as shown in the figure. Ensure that the orientation of RF port of antenna and radio are in same direction</p>	
	<p>(2) Line up the radio assembly to four bolts and slide towards lower bracket assembly to lock.</p>	
	<p>(3) Tighten the radio assembly plate using four M8 bolts to a torque setting of 2 ± 0.5 Nm.</p>	

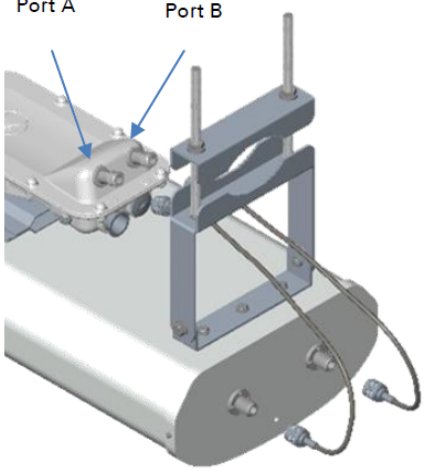
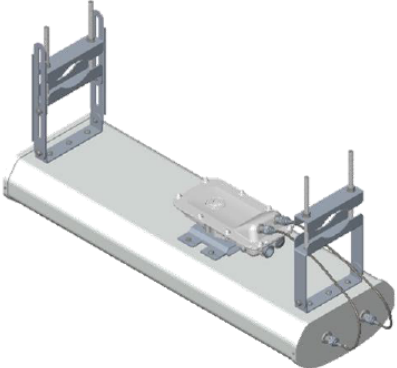
5	<p>(1) Connect the port A of AP to vertical and port B of AP to horizontal polarization interfaces of the antenna with RF cable. Ensure that the RF cables are pass-through inside the lower bracket assembly</p>	
	<p>(2) Hand tighten the N type connectors and the torque should not exceed more than 1 Nm</p>	

Mounting of PMP 450i AP 900 MHz antenna to the pole

The mounting procedure of PMP 450i AP 900 MHz and antenna to the pole is given below:

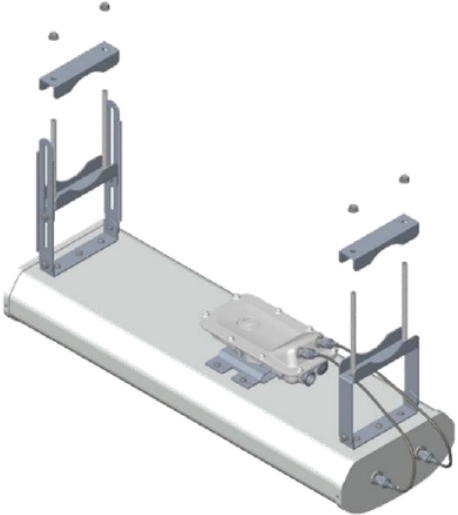
1	<p>Remove the upper and lower rear bracket strap from the sector antenna.</p>	
---	---	--

2

Attach the upper and lower bracket of the antenna to the mount point by closing the rear strap around the pole.



Note

Before mounting the radio on the pole, secure the upper and lower bracket assemblies with a torque setting of 3 to 4 Nm as shown in Figure 1. Also, ensure that inner strap of upper bracket is set to zero-degree marking.

Figure 143: Attaching radio mounting PMP 450i AP 900 MHz antenna to the pole

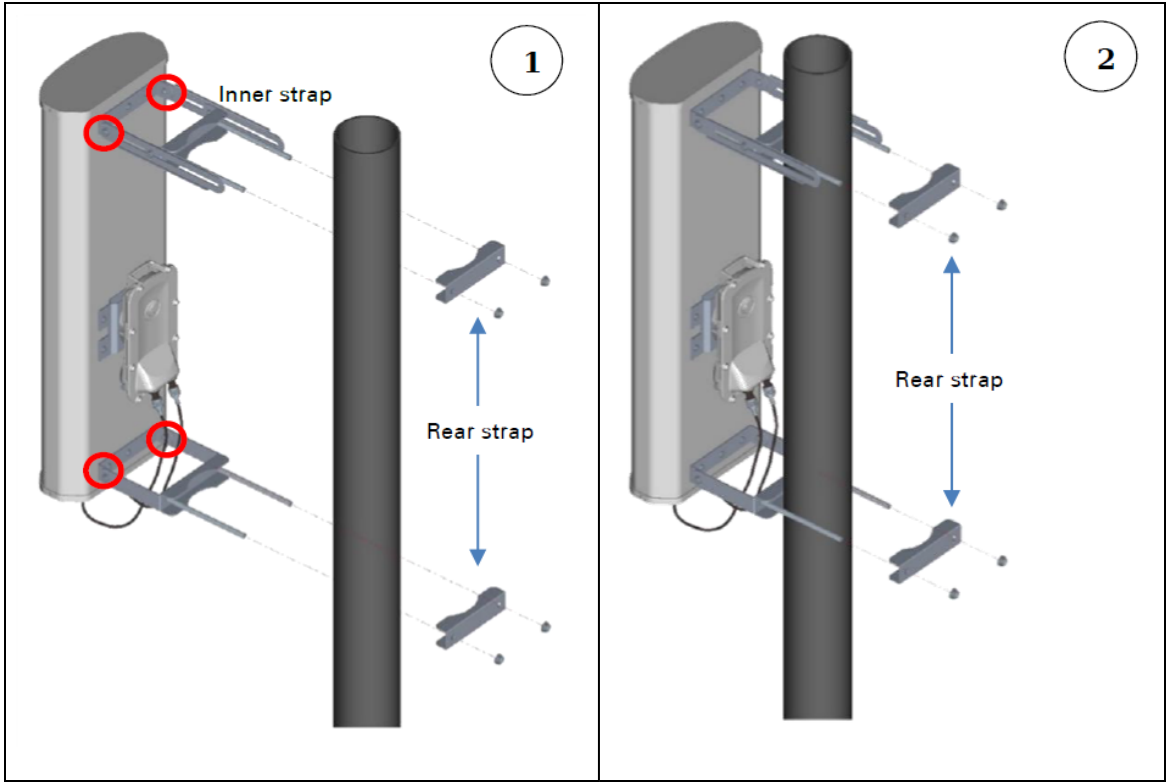

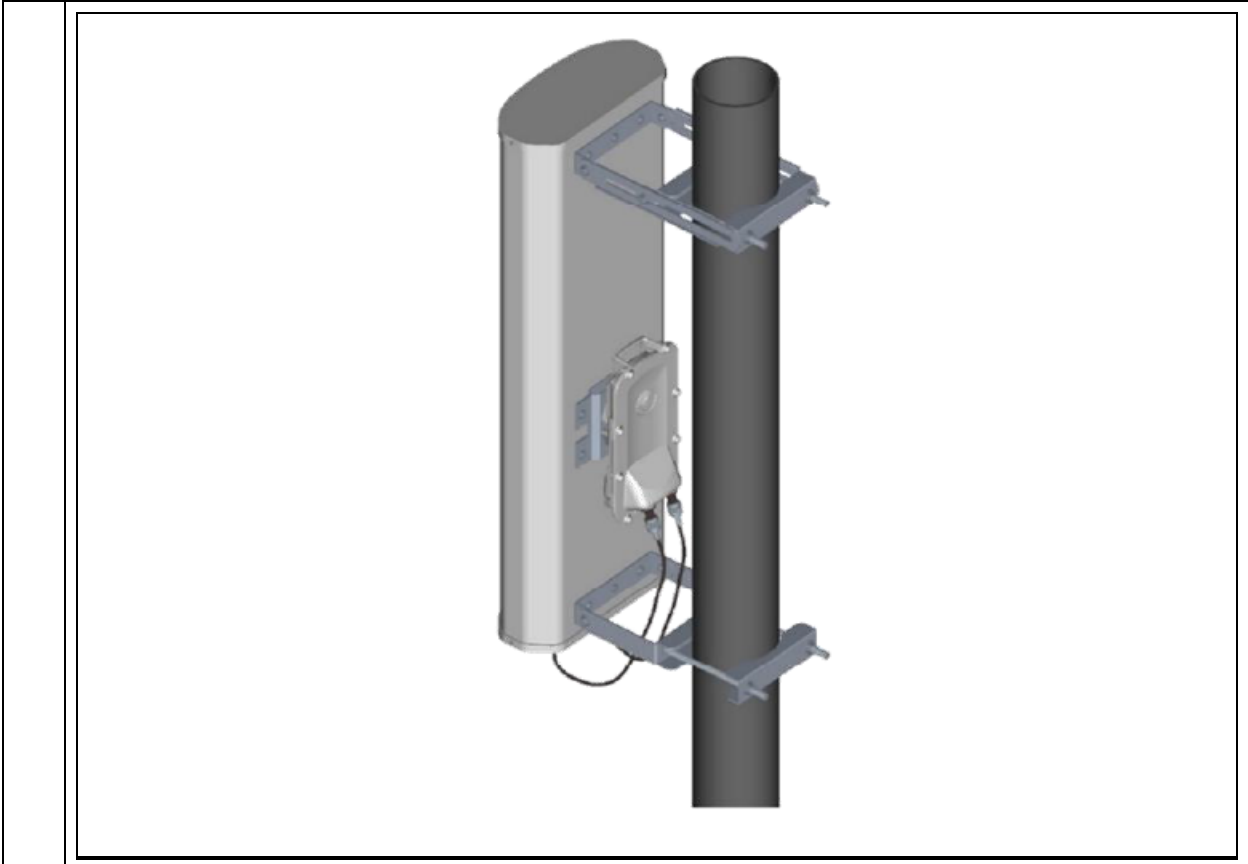

3 Tighten the four-serrated flange M10 nuts on the upper and lower rear straps using a 17 mm spanner wrench. These must be tightened evenly on the pole to avoid jumping/stripping threads

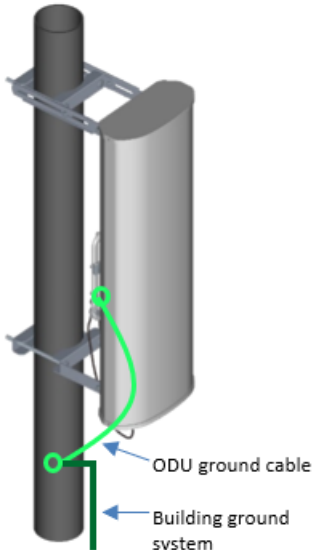

Sector antenna alignment

The 900 MHz sector antenna horizontal and vertical alignment procedure is shown in [900 MHz sector antenna alignment](#). The antenna can be aligned from +5 to -10 degree by adjusting the inner strap of the upper bracket assembly.

Figure 144: 900 MHz sector antenna alignment

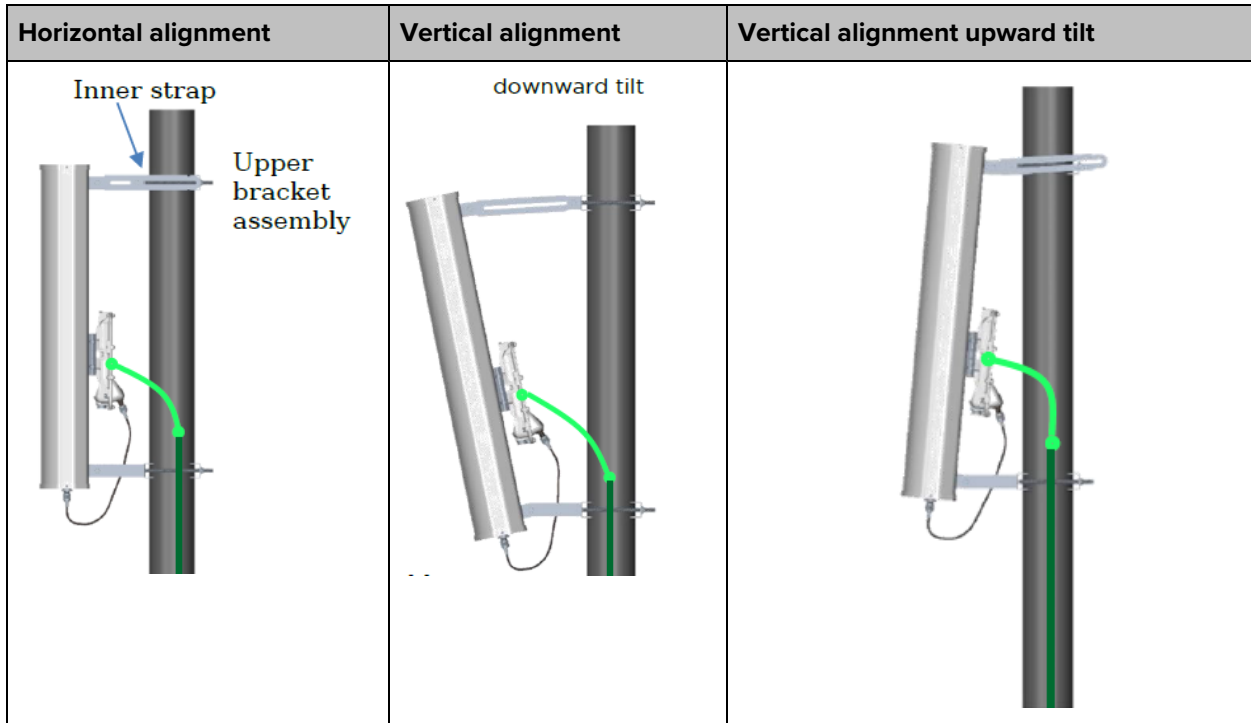

PMP 450 Series SM 900 MHz

Attaching the SM 900 MHz directional antenna to the pole

1	<p>Unbox the directional Yagi antenna.</p> <p>Figure 145: PMP 450i SM 900 MHz external directional antenna</p>
---	--

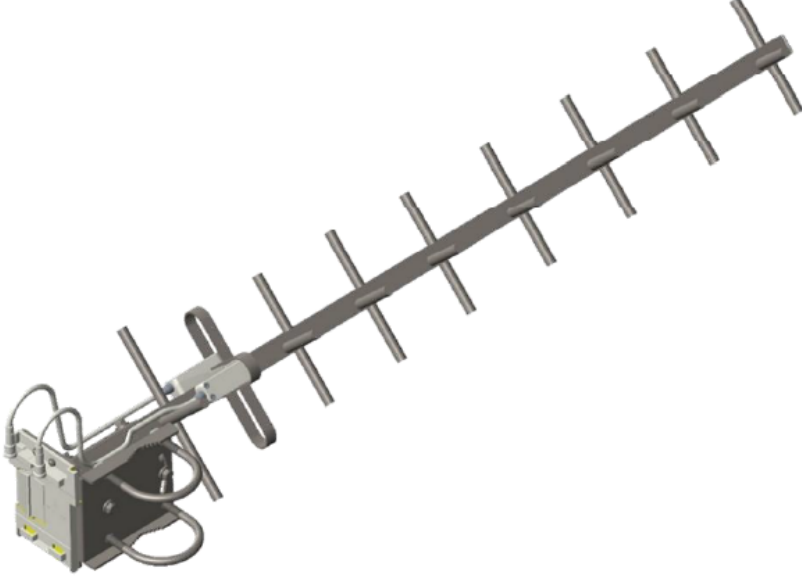
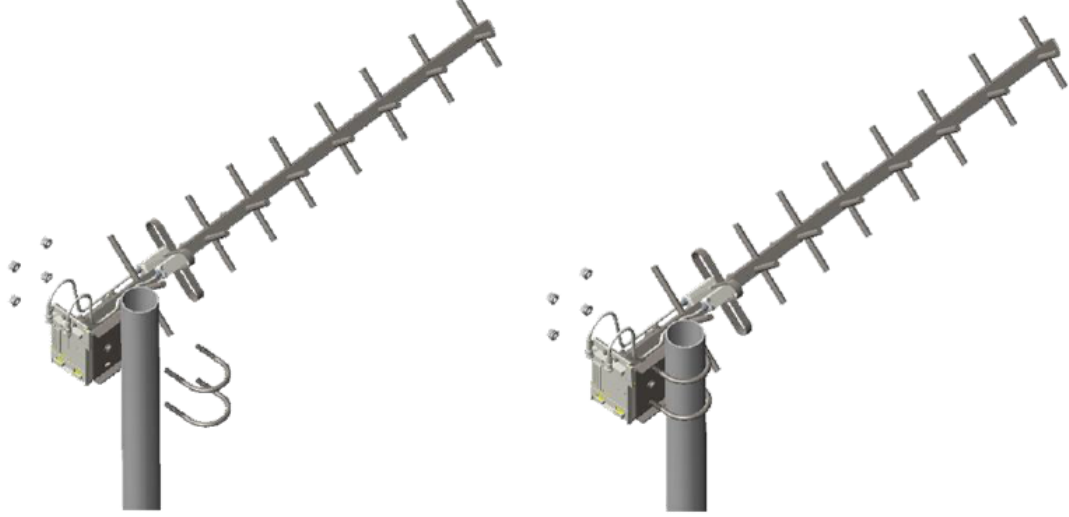
	
<p>2</p>	<p>Attach the directional antenna to the pole and insert the two U clamps into the mounting bracket of the antenna</p> <p><i>Figure 146: Attach the antenna to the pole</i></p> 
<p>3</p>	<p>Tighten all nuts to approximately 6 to 7 Nm or less to avoid deforming the pole.</p> <p><i>Figure 147: Fixing the nuts</i></p>

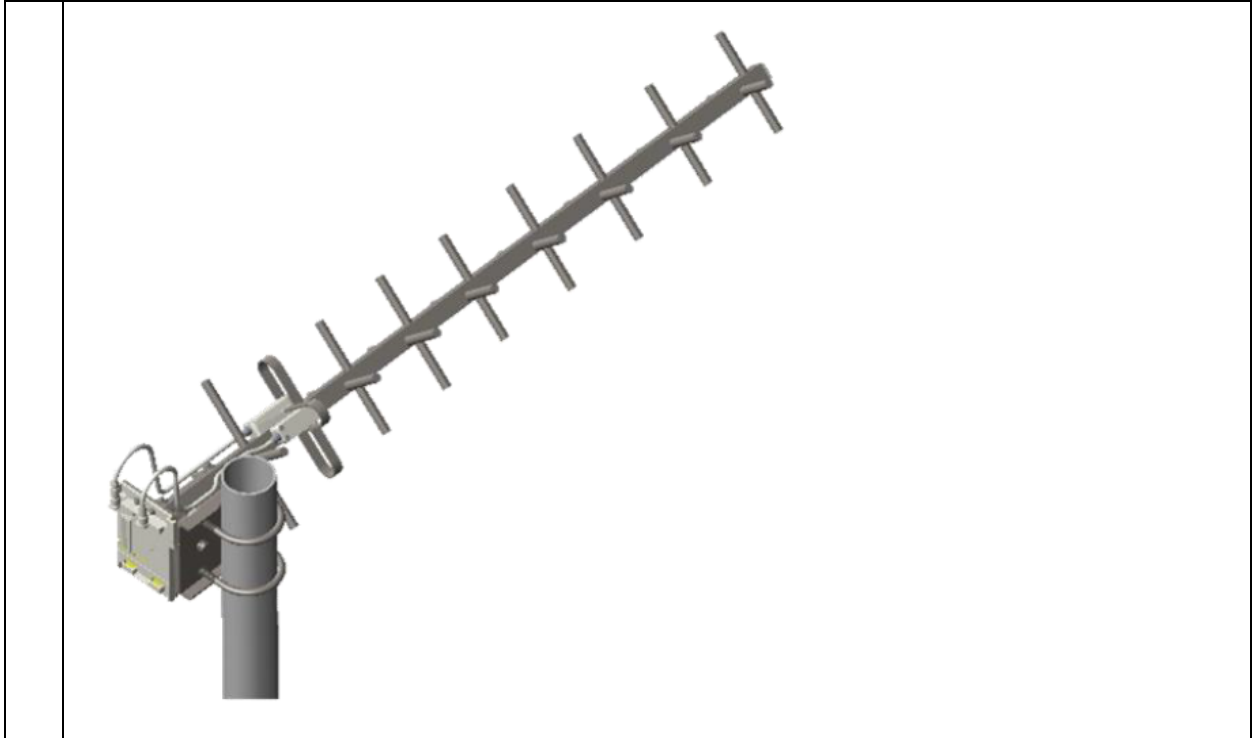

Radio mounting to the antenna

- 1 Align the radio to E bracket and slide towards right to lock on the antenna as shown in below figure.

Figure 148: Fixing the radio to the antenna

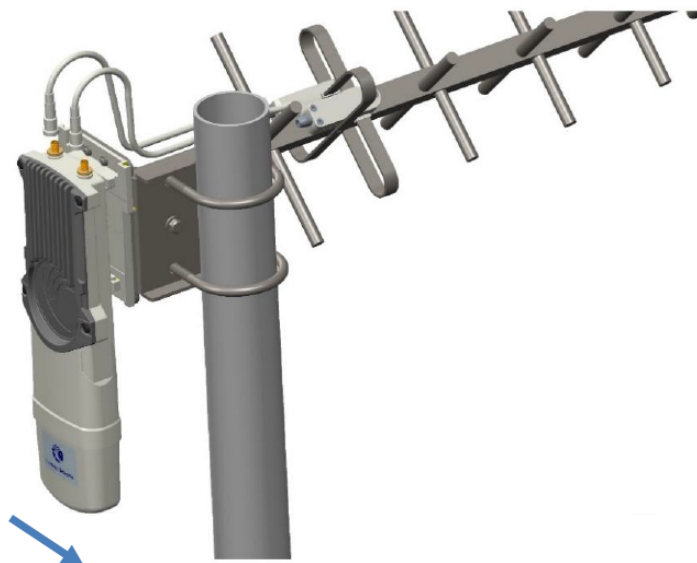

Slide towards right to lock

2

Connect the port A of SM to vertical and port B of SM to horizontal polarization interfaces of the antenna with RF cable.

Figure 149: Connecting RF cable to the radio

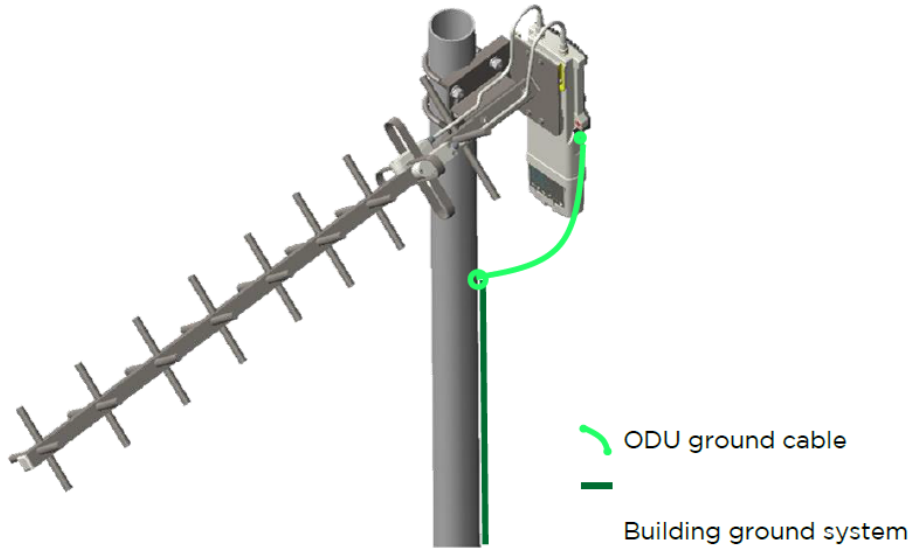

Directional Yagi antenna alignment

The directional Yagi antenna horizontal and vertical alignment procedure is shown below. The Yagi antenna can be aligned for +15 to -15 degree.

Figure 150: Yagi antenna alignment - horizontally

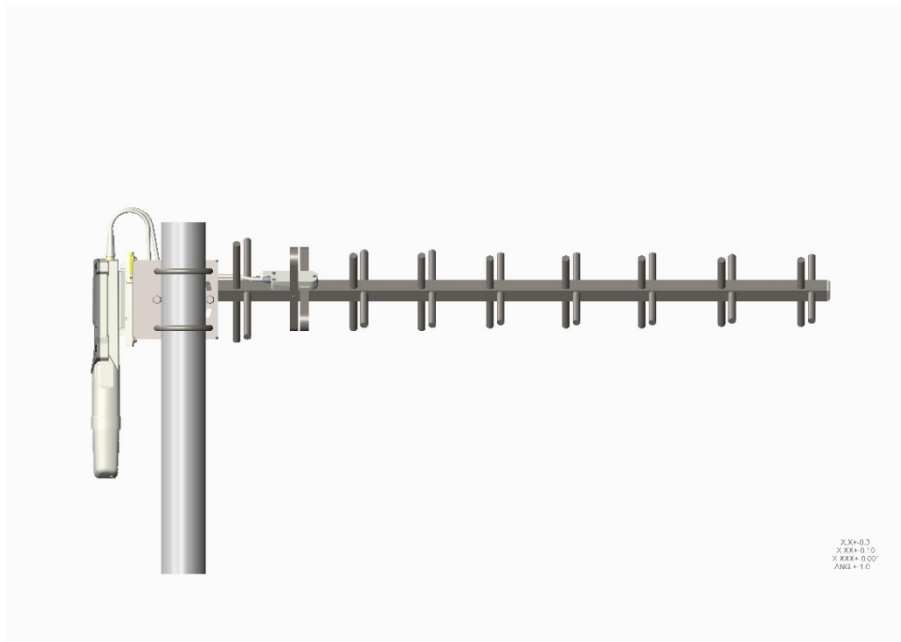

Figure 151: Yagi antenna alignment - upward tilt

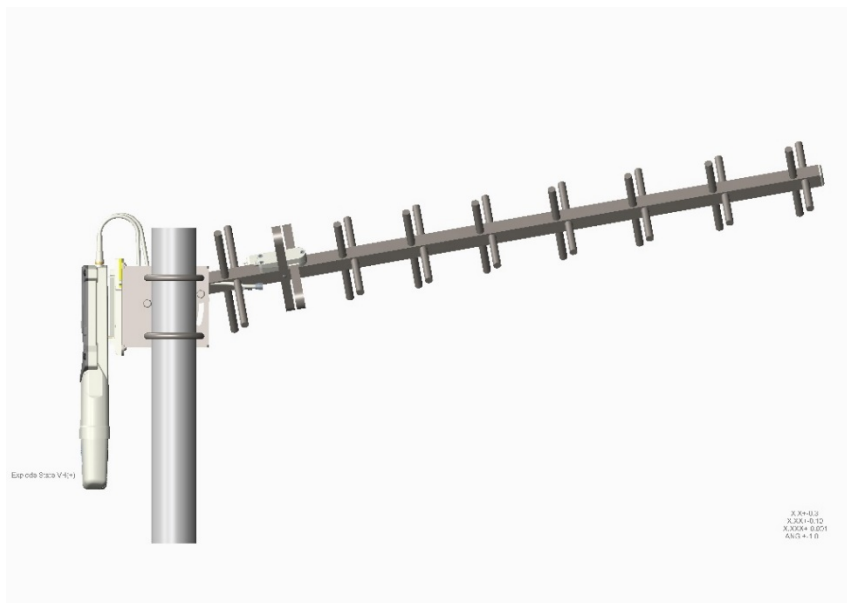
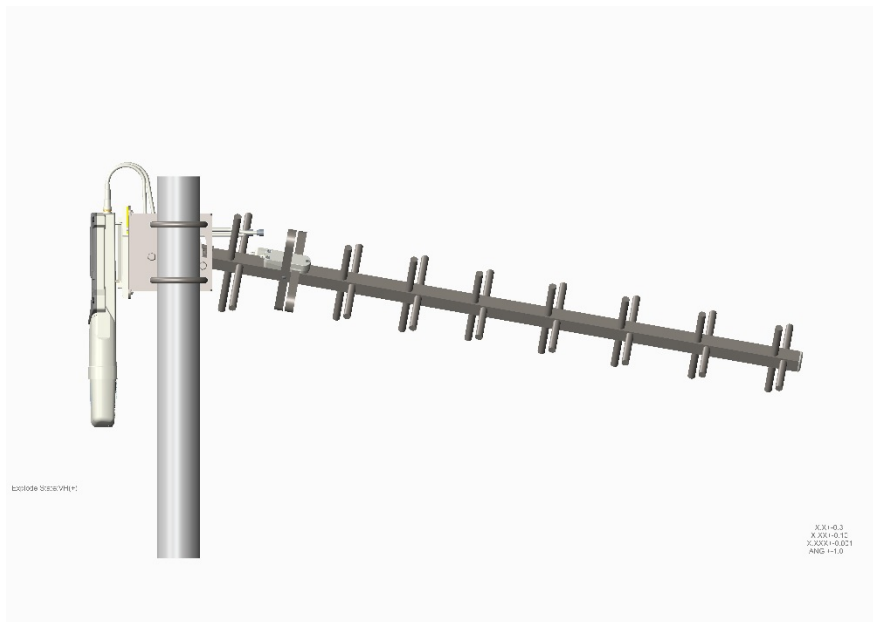

Figure 152: Yagi antenna alignment - downward tilt



Alignment of the 4x4 PMP 450v SM/BHS

The 4x4 PMP 450v SM/BHS is the first SM in the Cambium PMP line with four chains.

All previous SM/BHS had two orthogonal chains with a single peak in the azimuth antenna pattern, while the 4x4 SM/BHS has two peaks because the two carrier feeds are offset as part of the design.

The picture below shows the antenna pattern in azimuth at various frequencies.

Note that this pattern is only for the 4x4 SM/BHS. The 4x4 AP has a sector antenna, and this characteristic of having two peaks does not apply to the AP.

At the SM/BHS, two of the chains have their peak of beam at an angle a few degrees negative, while the other two chains have their peak of beam at an angle a few degrees positive.

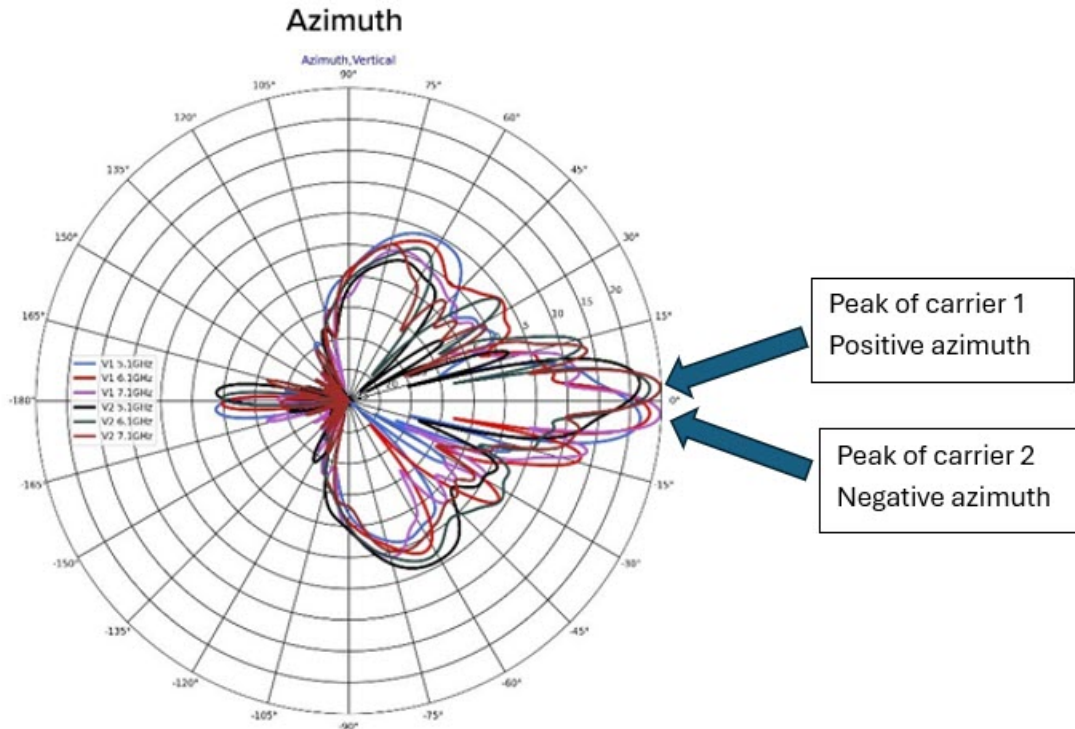

Each pair of chains transmits and receives a signal in one of the two carriers.



Note

The difference between carrier and component carrier:

- Carrier: center frequency of a Tx/Rx chain.
Each Tx/Rx chain is used to transmit/receive all modulated component carriers that are wholly contained in the BW of the Tx/Rx chain.
- Component Carrier (CC): refers to the center frequency of an OFDM symbol.
Up to four CCs will be supported. Each CC must be associated with a carrier.

Examples

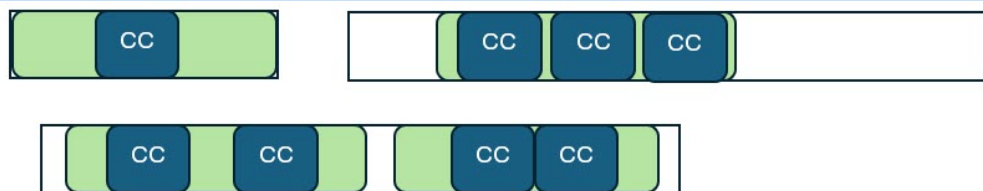

When aligning this antenna, it is important to point towards the AP in the middle (azimuth 0 degrees), not at one of the two peaks. If one of the two peaks is aligned with the AP, the carrier associated with that peak will experience a higher link budget, but the carrier associated with the other peak will experience a significantly lower link budget.

The best overall performance is achieved when the SM is aligned with the AP in the middle of the two peaks.

Enable two carriers at the AP when aligning the SM

Assume the AP is operating on a single carrier. Out of the two pairs of chains in the SM, one pair receives the signal, while the other does not receive anything.

When moving the SM to look for the peak of the beam, the beam associated with the one active carrier will be aligned with the AP. Single-carrier operation is now possible.

Assume at a later time the AP enables a second carrier. The second pair of chains now receives the signals several degrees off in azimuth, experiencing a much lower link budget. When enabling the second carrier, it is then necessary to re-align the SM, so that the AP is aligned in the middle of the two peaks of the SM. After re-alignment, the carrier that was originally operating will see its link budget degrade slightly, as that beam is no longer at its peak, but the other carrier will see a significant improvement, as its peak is now closer to the center point.

If the AP is currently operating on a single carrier, it is recommended to enable a second carrier during the SM installation to allow for correct alignment, avoiding having to re-align the SM later.

Also note that for a more accurate alignment, the EIRP of the AP in the two carriers needs to be the same.

How to check for correct alignment

To align an SM/BHS, there are three options.

- Alignment tone

Installation with the alignment tone for the 4x4 PMP 450v SM/BHS is similar to installations with previous 2x2 SM/BHS. The audio tone is proportional to the received signal strength; when the user moves the SM, the audio tone indicates a stronger or weaker signal, and it aids in aligning the SM.

With the 4x4 PMP 450v SM/BHS, the audio tone indicates the signal strength of the two carriers combined. The user is still looking for a position that maximizes the overall signal strength. This method is accurate only if the EIRP of the AP in the two carriers is the same.

Note that this combined carrier power is an average of the two carriers signals, and not the sum.

- cnArcher: cnArcher currently does not support alignment for the 4x4 450v SMs.

- Alignment page in SM/BHS GUI

In the 4x4 PMP 450v SM/BHS GUI, navigate to the **Tools > Alignment Tools** tab, where the receive power levels are displayed, both per carrier and combined.

Note that this combined carrier power is an average of the two carriers signals, and not the sum.

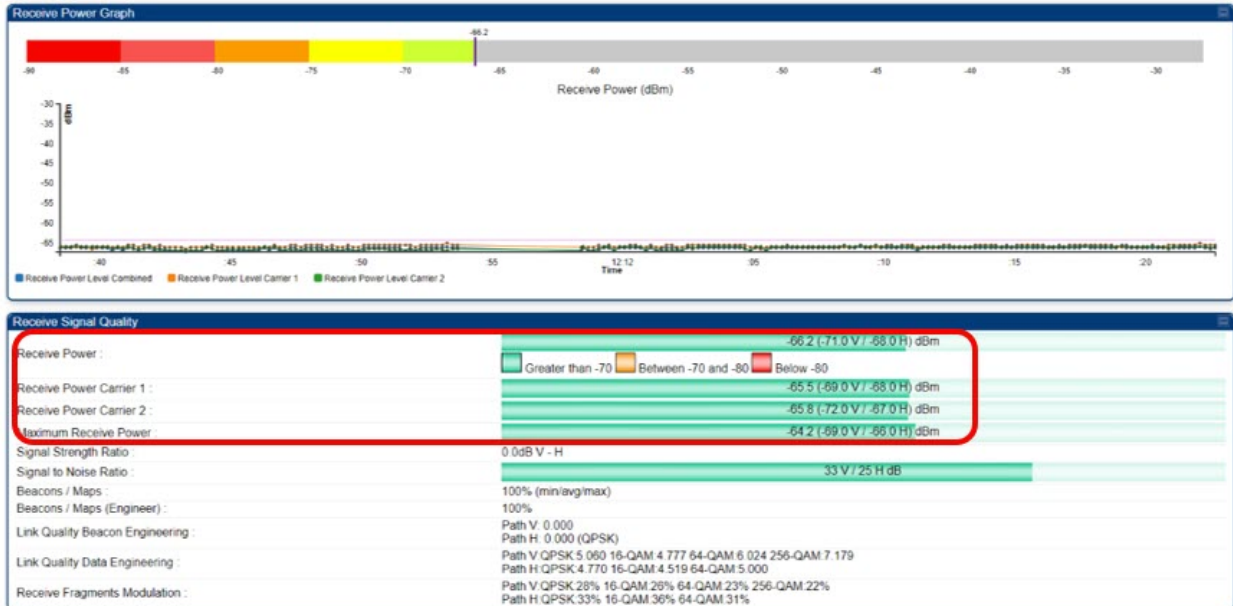

- This is not strictly necessary, but after aligning in elevation, it may be good practice to move the SM slightly in azimuth again and make sure it is still at the peak of the Receive Power.

Installing an integrated ODU



Caution

Do not reverse the bracket clamp, as this arrangement may lead to failure of the assembly. Do not over-tighten the bolts as this may lead to failure of the assembly.

PMP 450m Series – 5 GHz AP

To mount and connect an integrated ODU, proceed as follows:

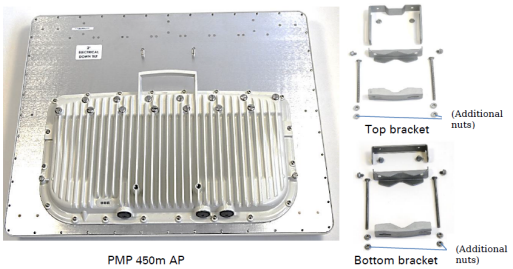
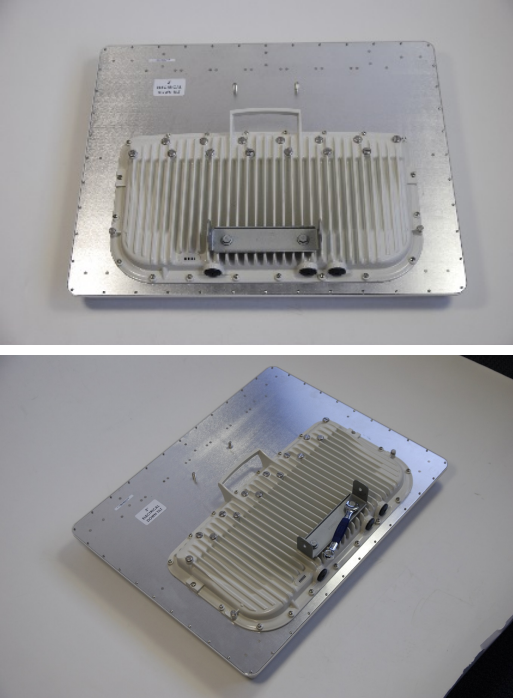
<p>1</p>	<p>Inventory the parts to ensure that you have them all before you begin. The full set of parts is shown in PMP 450m Series - 5 GHz AP unbox view.</p> <div data-bbox="267 856 337 934" data-label="Image"> </div> <div data-bbox="402 850 885 1018" data-label="Text"> <p>Note The additional nuts provided for top and bottom brackets are used to hold the long bolts in position during installation.</p> </div>	<p>PMP 450m Series - 5 GHz AP unbox view</p>  <p>PMP 450m AP</p> <p>Top bracket (Additional nuts)</p> <p>Bottom bracket (Additional nuts)</p>
<p>2</p>	<p>Attach the bottom bracket to the ODU using (2) hex bolts and secure the M8 bolts by applying 5 Nm torque.</p>	

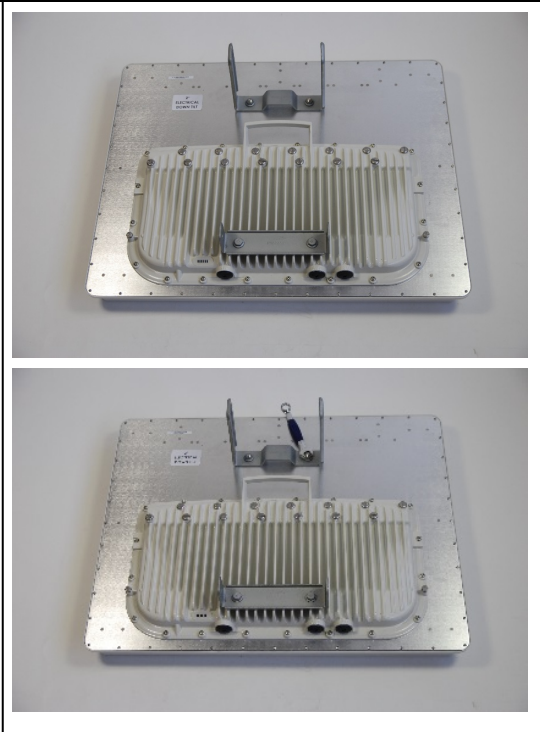
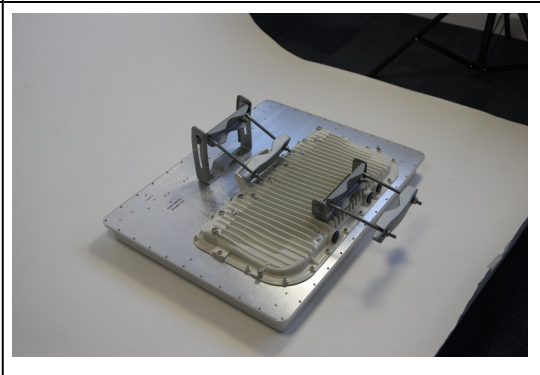
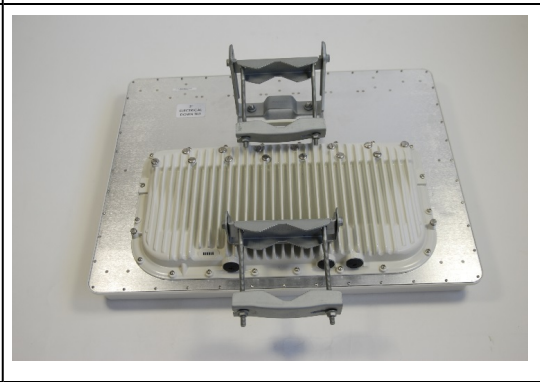
<p>3</p>	<p>Attach the top bracket to the projecting studs on the ODU and secure the top bracket using two M8 nuts by applying 5 Nm torque.</p>	
<p>4</p>	<p>Fix the front and rear strap assembly to the upper bracket using two bolts. Do not tighten the nuts now.</p> <div data-bbox="267 1031 337 1108" data-label="Image"> </div> <div data-bbox="399 1024 883 1155" data-label="Text"> <p>Note The PMP 450m antenna operates with 2 degrees of electrical down-tilt.</p> </div>	
<p>5</p>	<p>Fix the front and rear strap assembly to the bottom bracket using two bolts. Do not tighten the nuts now.</p>	

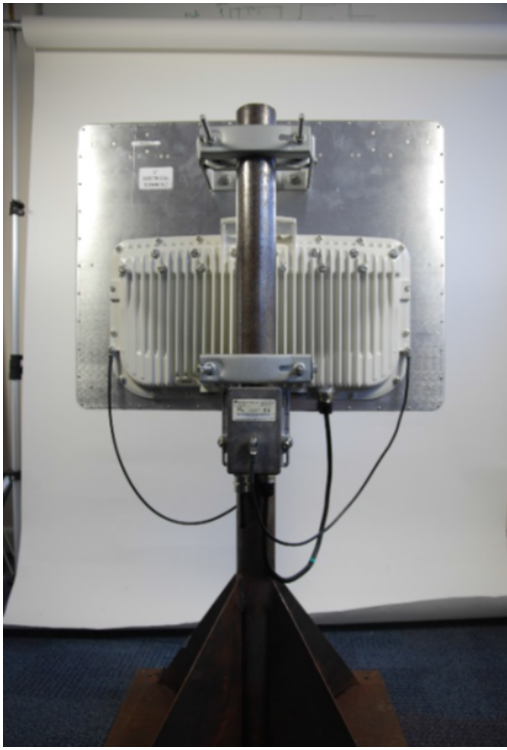

6	<p>See PMP 450m Series – AP for the grounding procedure.</p> <p>See PMP 450m Series – AP for the mounting procedure.</p>	
---	--	--

PMP 450m Series – 3 GHz AP

To mount and connect an integrated ODU, proceed as follows:

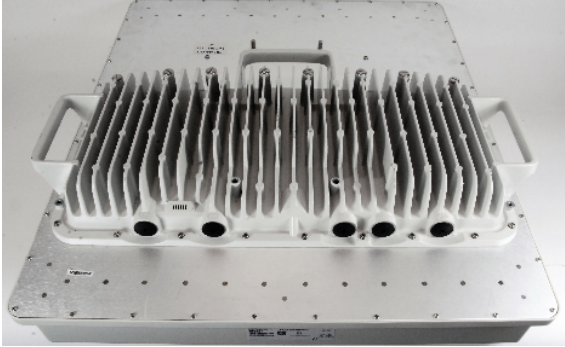
1	<p>Inventory the parts to ensure that you have them all before you begin. The full set of parts is shown in PMP 450m Series - 5 GHz AP unbox view.</p> <div data-bbox="267 1354 349 1438" style="display: inline-block; vertical-align: middle;">  </div> <div data-bbox="397 1354 673 1627" style="border: 1px solid black; padding: 5px; margin-left: 20px;"> <p>Note</p> <p>The additional nuts provided for top and bottom brackets are used to hold the long bolts in position during installation.</p> </div>	<p>PMP 450m Series - 3 GHz AP unbox view</p>
---	---	--

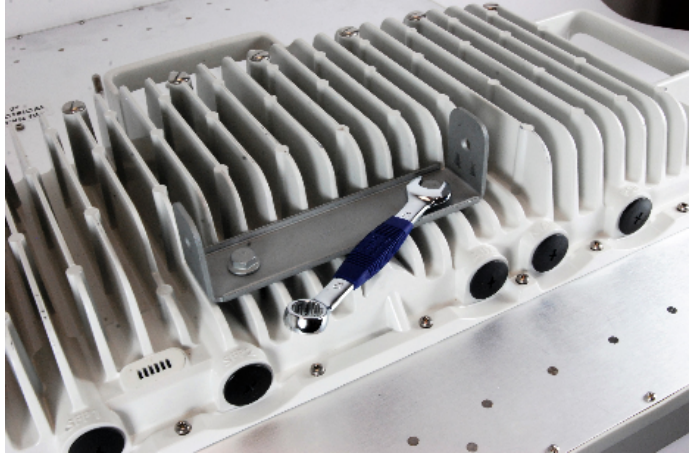
		 <p>PMP 450m AP - 3 GHz</p>  <p>Top bracket</p>  <p>Bottom bracket</p>
2	<p>Attach the bottom bracket to the ODU using (2) hex bolts and secure the M8 bolts by applying 5 Nm torque.</p>	

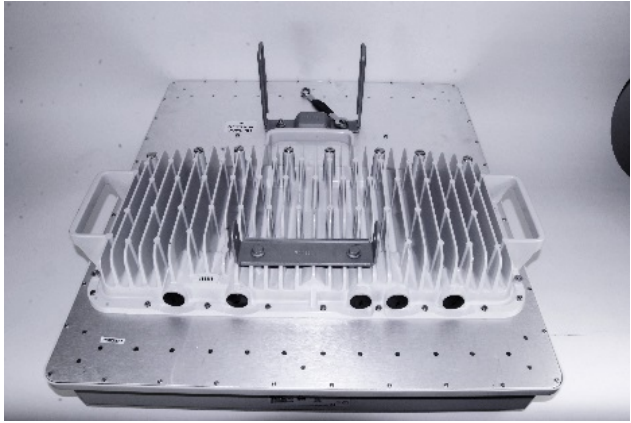
		
3	<p>Attach the top bracket to the projecting studs on the ODU and secure the top bracket using two M8 nuts by applying 5 Nm torque.</p>	 

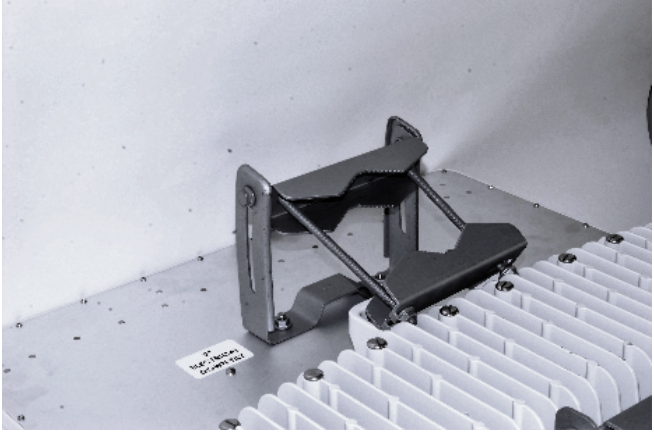
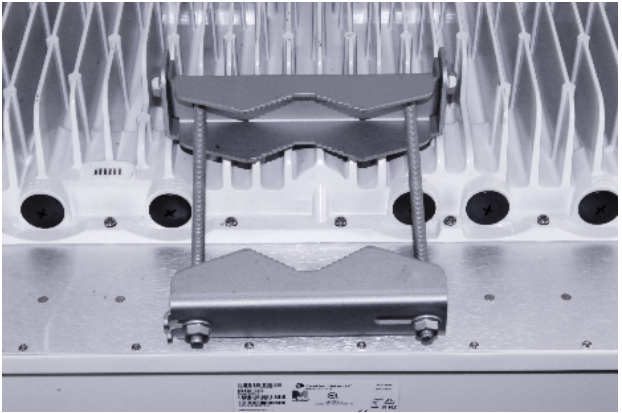
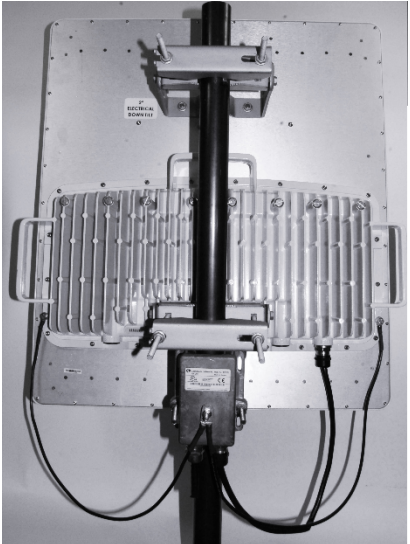
4	<p>Fix the front and rear strap assembly to the upper bracket using two bolts. Do not tighten the nuts now.</p> <div data-bbox="272 373 675 533" style="border: 1px solid black; padding: 5px; margin-top: 10px;">  <p>Note The PMP 450m antenna operates with 2 degrees of electrical down-tilt.</p> </div>	
5	<p>Fix the front and rear strap assembly to the bottom bracket using two bolts. Do not tighten the nuts now.</p>	
6	<p>See PMP 450m Series – AP for the grounding procedure.</p> <p>See PMP 450m Series – AP for the mounting procedure.</p>	

PMP/PTP 450i Series – AP/SM/BH

To mount and connect an integrated ODU, proceed as follows:

1. Fix the mounting plate to the back of the ODU using the four M6 bolts, and spring and plain washers provided. Tighten the bolts to a torque setting of 5.0 Nm (3.7 lb ft).

Figure 153: Fixing the mounting plate to the back of the ODU

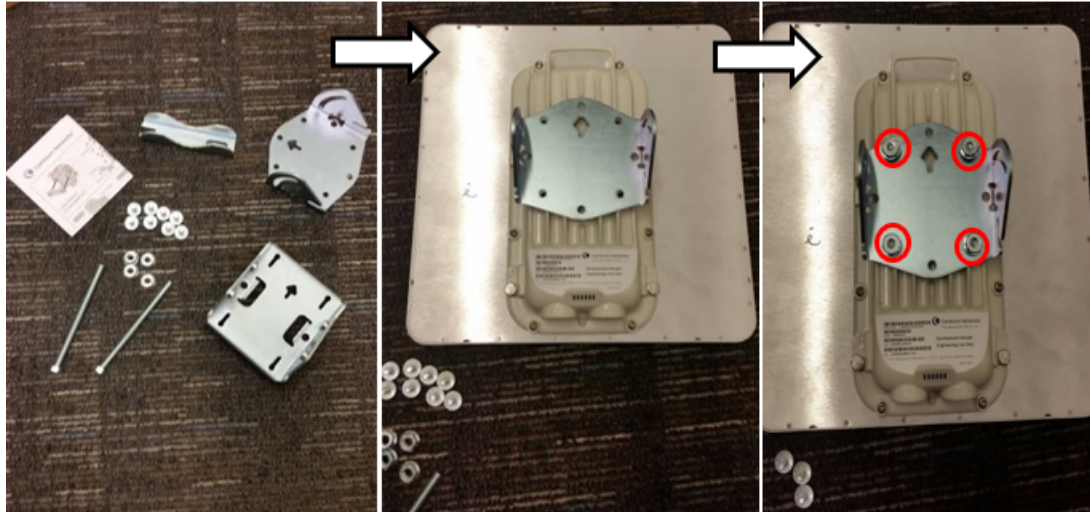

2. Attach the bracket body to the mounting plate using the M8 bolt, spring and plain washers.
3. Hoist the ODU to the mounting position.
4. Attach the bracket body to the pole using the bracket clamp, M8 bolts, and spring and plain washers.
5. If the ODU is mounted outdoors, weatherproof the N type connectors (when antenna alignment is complete) using PVC tape and self-amalgamating rubber tape.

Figure 154: Attaching the bracket body



Connecting Cat5e Ethernet cable

Connecting an RJ45 and gland to a unit

Perform this task to connect the Ethernet cable to an AP.

To connect the Ethernet cable with a gland to an AP unit, proceed as follows:

1	Insert the RJ45 cable through the gland components
2	Insert the RJ45 plug into the socket in the unit, making sure that the locking tab snaps home.
3	Support the drop cable and gently hand screw the gland body into the unit until the bushing seal is flush to the unit body.  Note Do not fit the back shell prior to securing the gland body.
4	Once the gland is fully hand screwed into the unit, tighten it one full rotation only with a 1 1/8 inch spanner wrench.
5	When the gland body has been fitted, tighten the gland back shell



Caution

Do not over-tighten the gland back shell, as the internal seal and structure or RJ45 port may be damaged.

Figure 155: Ethernet cable gland for PMP/PTP 450 Series



Figure 156: Ethernet cable gland for PMP/PTP 450i Series



Disconnecting an RJ45 and gland from a unit

To disconnect the Ethernet cable and gland from a unit, proceed as follows:

1	Hold the Ethernet cable and remove the gland back shell.
2	Use a small flathead screwdriver (0.2"/5mm wide or greater) to gently release the black plastic watertight bushing from the compression fins, being careful not to damage the bushing.
3	Unscrew the gland body from the AP, making sure that the Ethernet cable is not rotating while disengaging the gland body from the AP housing.
4	Use a small screwdriver to depress the RJ45 locking clip.
5	Unplug the RJ45 cable.
6	Remove the gland from the cable, if necessary.

Installing ODU

Installing a 450 Platform Family AP

To install a 450 Platform Family AP, perform the following steps.

Procedure 5: Installing an AP

1	Begin with the AP in the powered-down state.
2	<p>Choose the best mounting location for your particular application. Modules need not be mounted next to each other. They can be distributed throughout a given site. However, the 60° offset must be maintained. Mounting can be done with supplied clamps.</p> <p>See Installing external antennas to a connectorized ODU for connecting an external antenna to PMP 450i Series, PMP 450 Series, PMP 450m Series – 5 GHz AP, PMP 450m Series – 3 GHz AP, and PMP 450 Series SM 900 MHz</p> <p>See</p>
3	<p>Align the AP as follows:</p> <ol style="list-style-type: none"> 1. Move the module to where the link will be unobstructed by the radio horizon and no objects penetrate the Fresnel zone. 2. Use a local map, compass, and/or GPS device as needed to determine the direction that one or more APs require to each cover the intended 60° sector. 3. Apply the appropriate degree of downward tilt. 4. Ensure that the nearest and furthest SMs that must register to this AP are within the beam coverage area.
4	Adjust the azimuth to achieve visual alignment, lock the AP in the proper direction and downward tilt.
5	Attach the cables to the AP (See Powering the AP/SM/BH for test configuration)
6	Waterproof the cables (See section Attaching and weatherproofing an N type connector).

Installing a 450 Platform Family SM

Installing a 450 Platform Family SM consists of two procedures:

- Physically installing the SM on a residence or other location and performing a coarse alignment using the alignment tool or alignment tone.
- Verifying the AP to SM link and finalizing alignment using review of power level, link tests, and review of registration and session counts.

Procedure 6: Installing an SM

1	Choose the best mounting location for the SM based on section ODU and external antenna location .
2	<p>Use stainless steel hose clamps or equivalent fasteners to lock the SM into position.</p> <p>See Installing external antennas to a connectorized ODU for connecting external antenna</p> <p>See</p>

3	Remove the base cover of the SM.						
4	Terminate the UV outside grade Category 5 Ethernet cable with an RJ-45 connector, and connect the cable to the SM.						
5	Wrap a drip loop in the cable.						
6	For Connectorized Models, Install the external antenna according to the manufacturer's instructions.						
7	For Connectorized Models, connect the SM's N-type antenna connectors to the external antenna, ensuring that the polarity matches between the SM cable labeling and the antenna port labels. <table border="1" data-bbox="277 590 1419 758"> <thead> <tr> <th>Connectorized SM Antenna Cable Label</th> <th>Antenna Connection</th> </tr> </thead> <tbody> <tr> <td>A</td> <td>Vertical</td> </tr> <tr> <td>B</td> <td>Horizontal</td> </tr> </tbody> </table>	Connectorized SM Antenna Cable Label	Antenna Connection	A	Vertical	B	Horizontal
Connectorized SM Antenna Cable Label	Antenna Connection						
A	Vertical						
B	Horizontal						
8	For Connectorized Models, weatherproof the N-type antenna connectors following section Attaching and weatherproofing an N type connector .						
9	Wrap an AWG 10 (or 6mm ²) copper wire around the Ground post of the SM						
10	Securely connect the copper wire to the grounding system (Protective Earth) according to applicable regulations.						
11	Install a surge suppressor as described in the section Mount the Surge Suppressor .						
12	Connect the power supply to a power source.						
13	Connect the Ethernet output from the Data port of the power supply to the Ethernet port of your laptop.						
14	Connect the drop cable from ODU to the Data+power port of the power supply.						
15	Launch your web browser. In the URL address bar, enter 169.254.1.1. then press Enter.						
16	If the browser in laptop fails to access the interface of the SM, follow the procedure Radio recovery mode .						
17	Log in as admin on the ODU. Configure a password for the admin account and log off.						
18	Log back into the SM as admin or root, using the password that you configured.						
19	For coarse alignment of the SM, use the Alignment Tool located at Tools, Alignment Tool. Optionally, connect a headset to the AUX/SYNC port on the SM and listen to the alignment tone, which indicates greater SM receive signal power by pitch. By adjusting the SM's position until the highest frequency pitch is obtained operators and installers can be confident that the SM is properly positioned. For information on device GUI tools available for alignment, see sections Using the Alignment Tool, Using the Link Capacity Test tool, and Using AP Evaluation tool in Configuration Guide.						

20	When the highest power is achieved, lock the SM mounting bracket in place.
21	Log off of the SM web interface.
22	Disconnect the Ethernet cable from your laptop.
23	Replace the base cover of the SM.
24	Connect the Ethernet cable to the computer that the subscriber will be using.

Installing a 450 Platform Family BHM

To install a 450 Platform Family BHM, perform the following steps.

Procedure 7: Installing a BHM

1	Choose the best mounting location for your particular application.
2	Align the BHM as follows: <ul style="list-style-type: none"> • Move the module to where the link will be unobstructed by the radio horizon and no objects penetrate the Fresnel zone. • Use a local map, compass, and/or GPS device as needed to determine the direction to the BHS. • Apply the appropriate degree of downward or upward tilt. • Ensure that the BHS is within the beam coverage area.
3	Using stainless steel hose clamps or equivalent fasteners, lock the BHM into position. See Installing external antennas to a connectorized ODU for connecting external antenna
4	If this BHM will not be connected to a CMM, optionally connect a cable to a GPS timing source and then to the SYNC port of the BHM.
5	Either connect the BHM's Aux to the CMM or connect the DC power converter to the BHM and then to an AC power source. RESULT: When power is applied to a module or the unit is reset on the web-based interface, the module requires approximately 25 seconds to boot. During this interval, self-tests and other diagnostics are being performed.
6	Access Configuration > General page of the BHM for Synchronization configuration.
7	If a CMM4/CMM5 is connected, set the Sync Input parameter to the AutoSync or Autosync + Free Run selection.

Installing a 450 Platform Family BHS

To install a PTP 450 platform Series BHS, perform the following steps.

Procedure 8: Installing a BHS

1	Choose the best mounting location for the BHS.
2	Terminate the UV outside grade Category 5 Ethernet cable with an RJ-45 connector and connect the cable to the BHS. (See Powering the AP/SM/BH for test configuration)
3	Use stainless steel hose clamps or equivalent fasteners to lock the BHS into position.
4	Install a surge suppressor as described in the section Mount the Surge Suppressor
5	<p>For coarse alignment of the BHS, use the Audible Alignment Tone feature as follows:</p> <ul style="list-style-type: none">• At the BHS, connect the RJ-45 connector of the Alignment Tool Headset to the Aux port via an alignment tone adapter as shown in section Alignment Tone in Configuration Guide.• Listen to the alignment tone for pitch, which indicates greater signal power (RSSI/dBm) by higher pitch. <p>Adjust the module slightly until you hear the highest pitch and highest volume</p>
6	When you have achieved the best signal (highest pitch, loudest volume), lock the BHS in place with the mounting hardware

Configuring the Link

See Configuring remote access in Configuration Guide.

Monitoring the Link

See Monitoring the Link in Configuration Guide.

Installing the AC Power Injector



Caution

As the PSU is not waterproof, locate it away from sources of moisture, either in the equipment building or in a ventilated moisture-proof enclosure. Do not locate the PSU in a position where it may exceed its temperature rating.





Caution

Do not plug any device other than a PMP/PTP 450i Series ODU into the ODU port of the PSU. Other devices may be damaged due to the non-standard techniques employed to inject DC power into the Ethernet connection between the PSU and the ODU.

Do not plug any device other than a Cambium 450 Platform PSU into the PSU port of the ODU. Plugging any other device into the PSU port of the ODU may damage the ODU and device.

Follow this procedure to install the AC Power Injector:

1	Form a drip loop on the PSU end of the LPU to PSU drop cable. The drip loop ensures that any moisture that runs down the cable cannot enter the PSU.
2	(a) Place the AC Power Injector on a horizontal surface. Plug the LPU to PSU drop cable into the PSU port labeled ODU. (b) When the system is ready for network connection, connect the network Cat5e cable to the LAN port of the PSU:
	<div style="display: flex; justify-content: space-around;"> <div data-bbox="256 422 724 905" style="text-align: center;"> <p>(a)</p>  </div> <div data-bbox="841 422 1265 947" style="text-align: center;"> <p>(b)</p>  </div> </div>



Note

For instructions on CMM3 (CMMmicro) or CMM4/CMM5 installation, including the outdoor temperature range in which it is acceptable to install the unit, tools required, mounting and cabling instructions, and connectivity verification, please see the PMP Synchronization Solutions User Guide located on the Cambium website.

Installing CMM4, CMM5, and cnMatrix

For CMM3, CMM4, and CMM5 installation details, refer to the PMP Synchronization documentation on the Cambium Products site:

<https://support.cambiumnetworks.com/files/pmpacc/>

For cnMatrix installation, refer to the cnMatrix documentation on the Cambium Products site:

<https://support.cambiumnetworks.com/files/cnmatrix/>

Supplemental installation information

This section contains detailed installation procedures that are not included in the above topics, such as how to strip cables, create grounding points and weatherproof connectors.

Stripping drop cable

When preparing the drop cable for connection to the 450 Platform Family ODU or LPU, use the following measurements:

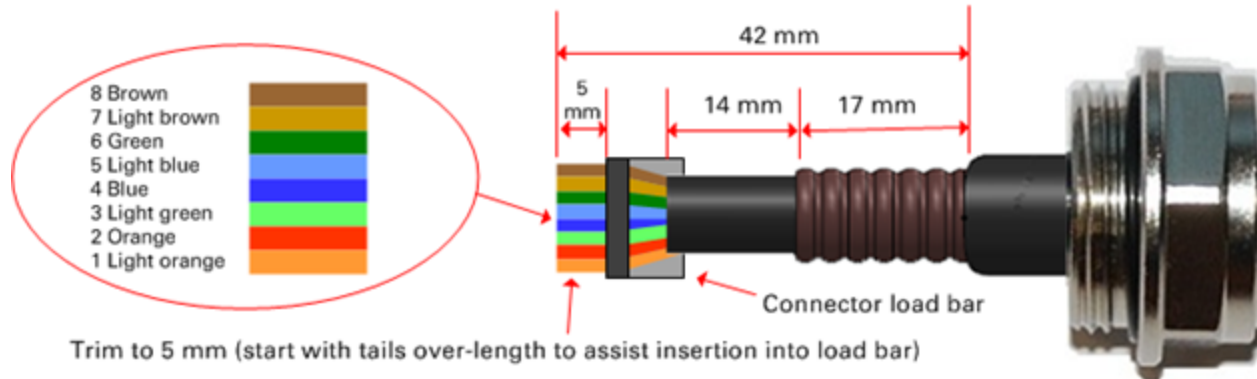

When preparing the drop cable for connection to the 450 Platform PSU (without a cable gland), use the following measurements:

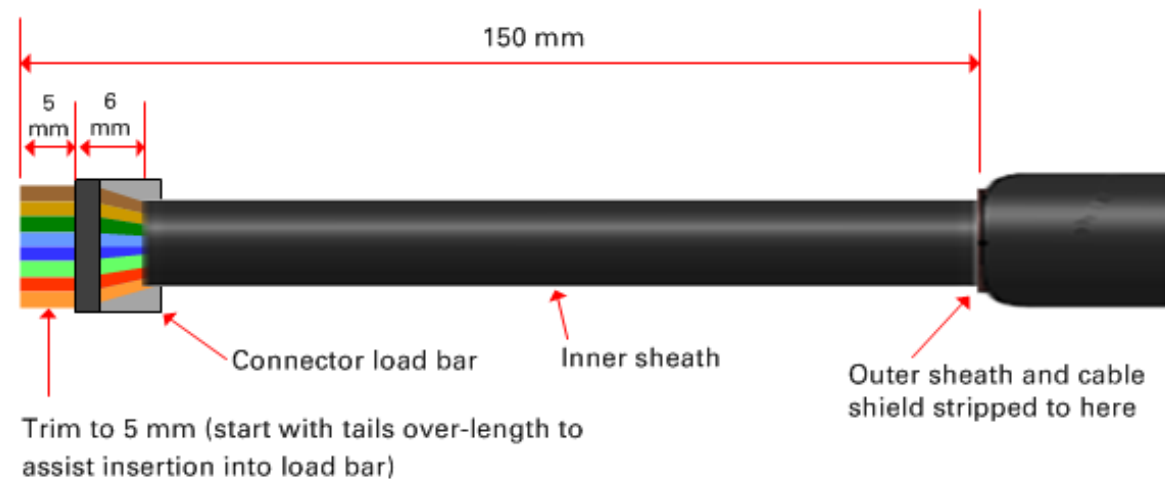





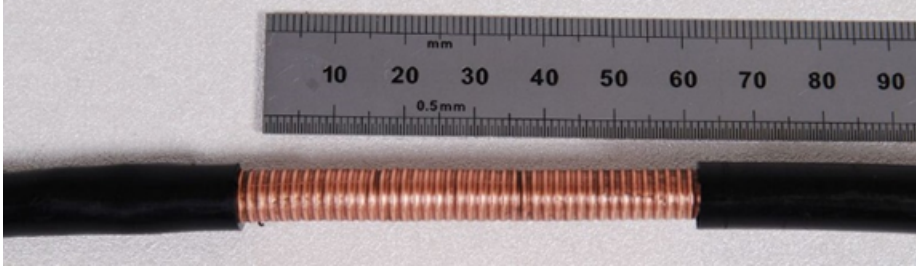

Creating a drop cable grounding point

Use this procedure to connect the screen of the main drop cable to the metal of the supporting structure using the cable grounding kit (Cambium part number 01010419001).

To identify suitable grounding points, refer to [Hazardous locations](#).

1	Remove 60 mm (2.5 inches) of the drop cable outer sheath.
---	---

	
2	<p>Cut 38mm (1.5 inches) of rubber tape (self-amalgamating) and fit to the ground cable lug. Wrap the tape completely around the lug and cable.</p> 
3	<p>Fold the ground wire strap around the drop cable screen and fit cable ties.</p> 
4	<p>Tighten the cable ties with pliers. Cut the surplus from the cable ties.</p> 
5	<p>Cut a 38mm (1.5 inches) section of self-amalgamating tape and wrap it completely around the joint between the drop and ground cables.</p>

	
6	<p>Use the remainder of the self-amalgamating tape to wrap the complete assembly. Press the tape edges together so that there are no gaps.</p> 
7	<p>Wrap a layer of PVC tape from bottom to top, starting from 25 mm (1 inch) below and finishing 25 mm (1 inch) above the edge of the self-amalgamating tape, overlapping at half width.</p> 
8	<p>Repeat with a further four layers of PVC tape, always overlapping at half width. Wrap the layers in alternate directions (top to bottom, then bottom to top). The edges of each layer should be 25mm (1 inch) above (A) and 25 mm (1 inch) below (B) the previous layer.</p>

	
9	Prepare the metal grounding point of the supporting structure to provide a good electrical contact with the grounding cable clamp. Remove paint, grease or dirt, if present. Apply anti-oxidant compound liberally between the two metals.
10	Clamp the bottom lug of the grounding cable to the supporting structure using site approved methods. Use a two-hole lug secured with fasteners in both holes. This provides better protection than a single-hole lug.

Attaching and weatherproofing an N type connector

The following procedure should be used to weatherproof the N type connectors fitted to the connectorized ODU (AP/sM/BH) and antenna. This procedure must be followed to ensure that there is no moisture ingress at the radio ports. Failure to properly seal N-type antenna connectors can result in poor link performance or complete loss of radio communication.



Note

Cambium recommends assembling the antenna, attach the ODU and cabling, and to seal the RF connections before installing the unit at the deployment site.







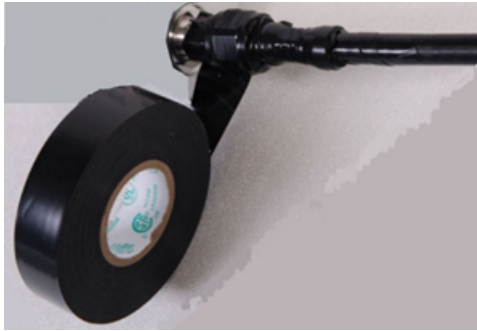

Note

N type connectors should be tightened using a torque wrench, set to 15 lb in or 1.7 Nm. If a torque wrench is not available, N type connectors may be finger tightened.

Use this procedure to weatherproof the N type connectors fitted to the connectorized ODU and external antenna (if recommended by the antenna manufacturer).

1	Ensure the connection is tight. A torque wrench should be used if available:
---	--

	
2	<p>Wrap the connection with a layer of 19 mm (0.75 inch) PVC tape, starting 25 mm (1 inch) below the connector body. Overlap the tape to half-width and extend the wrapping to the body of the LPU. Avoid making creases or wrinkles:</p> 
3	<p>Smooth the tape edges:</p> 
4	<p>Cut a 125mm (5 inches) length of rubber tape (self-amalgamating):</p> 

5	<p>Expand the width of the tape by stretching it so that it will wrap completely around the connector and cable:</p> 
6	<p>Press the tape edges together so that there are no gaps. The tape should extend 25 mm (1 inch) beyond the PVC tape:</p> 
7	<p>Wrap a layer of 50 mm (2 inch) PVC tape from bottom to top, starting from 25 mm (1 inch) below the edge of the self-amalgamating tape, overlapping at half width.</p> 
8	<p>Repeat with a further four layers of 19 mm (0.75 inch) PVC tape, always overlapping at half width. Wrap the layers in alternate directions:</p> <ul style="list-style-type: none"> • Second layer: top to bottom. • Third layer: bottom to top. • Fourth layer: top to bottom. • Fifth layer: bottom to top. <p>The bottom edge of each layer should be 25 mm (1 inch) below the previous layer.</p>

	
9	<p>Check the completed weatherproof connection:</p> 



Note
A video of this procedure can be found at: <https://www.youtube.com/watch?v=a-twPfcVq4A>

Chapter 6: Compliance with safety standards

This section lists the safety specifications against which the 450 Platform Family has been tested and certified. It also describes how to keep RF exposure within safe limits.

Electrical safety compliance

The 450 Platform Family hardware has been tested for compliance to the electrical safety specifications listed in [Safety compliance specifications](#).

Table 141: Safety compliance specifications

Region	Specification
USA	UL 60950-1 or UL 62368-1, UL 60950-22
Canada	CSA C22.2 No. 60950-1 or 62368-1, CSA C22.2 No 60950-22
International	CB certified & certificate to IEC 60950-1 or IEC 62368-1, IEC 60950-22

Electromagnetic compatibility (EMC) compliance

The EMC specification type approvals that have been granted for 450 Platform Family are listed under [EMC emissions compliance](#).

Table 142: EMC emissions compliance

Region	Specification
USA	FCC Part 15 Class B
Canada	RSS Gen
International	EN 301 489-1 V2.1.1 EN 301 489-17 V3.1.1 EN 301 489-4 V3.1.1

Human exposure to radio frequency energy

Relevant standards (USA and EC) applicable when working with RF equipment are:

- ANSI IEEE C95.1-2005, IEEE Standard for Safety Levels with Respect to Human Exposure to Radio Frequency Electromagnetic Fields, 3 kHz to 300 GHz.
- US FCC limits for the general population. See the FCC web site at <http://www.fcc.gov>, and the policies, guidelines, and requirements in Part 1 of Title 47 of the Code of Federal Regulations, as well

as the guidelines and suggestions for evaluating compliance in KDB 447498.

- Health Canada Safety Code 6 limits for the general population. See the Health Canada web site at <https://www.canada.ca/en/health-canada/services/environmental-workplace-health/consultations/limits-human-exposure-radiofrequency-electromagnetic-energy-frequency-range-3-300.html> and RSS-102.
 - BS EN 50385:2017 Product standard to demonstrate the compliances of radio base stations and fixed terminal stations for wireless telecommunication systems with the basic restrictions or the reference levels related to human exposure to radio frequency electromagnetic fields (110 MHz – 40 GHz) – general public.
- ICNIRP (International Commission on Non-Ionizing Radiation Protection) guidelines for the general public. See the ICNIRP web site at <https://www.icnirp.org/cms/upload/publications/ICNIRPemfgdl.pdf> and Guidelines for Limiting Exposure to Time-Varying Electric, Magnetic, and Electromagnetic Fields.

Power density exposure limit

Install the radios for the 450 Platform Family of wireless solutions so as to provide and maintain the minimum separation distances from all persons.

The applicable FCC power density exposure limit for RF energy in the 3, 4.9, 5.4 and 5.8 GHz frequency bands is 10 W/m² and in 900 MHz frequency band is 6 W/m². For more information, see [Human exposure to radio frequency energy](#) on page [Human exposure to radio frequency energy](#).

The applicable ISED power density exposure limit for RF energy in unlicensed bands is 0.02619 * (f^{0.6834}), where f is the lowest frequency of the supported band. For licensed bands, the power density exposure limit is 0.6455 * (f^{0.5}), where f is the lowest frequency of the supported band.

Calculation of power density

The following calculation is based on the ANSI IEEE C95.1-1991 method, as that provides a worst-case analysis. Details of the assessment to EN50383:2002 can be provided, if required.

Peak power density in the far field of a radio frequency point source is calculated as follows:

$$S = \frac{P \cdot G}{4 \pi d^2}$$

Where:		Is:	
	S		power density in W/m ²
	P		maximum average transmit power capability of the radio, in W
	G		total Tx gain as a factor, converted from dB
	d		distance from point source, in m

Rearranging terms to solve for distance yields:

$$d = \sqrt{\frac{P.G}{4\pi.S}}$$

Calculated distances and power compliance margins

The following tables show calculated minimum separation distances, recommended distances and resulting margins for each frequency band and antenna combination for the USA and Canada. These are conservative distances that include compliance margins. At these and greater separation distances, the power density from the RF field is below generally accepted limits for the general population.

450 Platform Family ODU adheres to all applicable EIRP limits for transmit power when operating in MIMO mode. Separation distances and compliance margins include compensation for both transmitters.

Explanation of terms used in the following tables:

- P burst – maximum average transmit power during transmit burst (Watt)
- P – maximum average transmit power of the radio (Watt)
- G – total transmit gain as a factor, converted from dB
- S – power density (Watt/m²)
- d – minimum safe separation distance from point source (meters)

Table 143: FCC minimum safe distances – PMP 450m 3 GHz and 5 GHz (5.1 GHz, 5.2 GHz, 5.4 GHz and 5.8 GHz)

Band (GHz)	Antenna	PG (W)	S (W/ m ²)	d (m)
3.65	90° sector	33.9	10	0.52
4.9	90° sector	174	10	1.08
5.1	90° sector	3.38	10	0.16
5.2	90° sector	0.85	10	0.08
5.4	90° sector	0.85	10	0.08
5.8	90° sector	3.38	10	0.16

Table 144: FCC minimum safe distances – PMP/PTP 450b 3.65 GHz, 4.9 GHz, 5.1 GHz, 5.2 GHz, 5.4 GHz, 5.8 GHz and 6 GHz

Band (GHz)	Antenna	P (W)	G (dBi)	S (W/ m2)	d (m)
3.65	Dish	0.199	20.0	10.0	0.40
4.9	Dish	0.501	24.0	10.0	1.00
	Patch Array	0.501	17.0	10.0	0.45
	On-board	0.501	0	10.0	0.06
5.1	Dish	0.501	24.0	10.0	1.00
	Patch Array	0.501	17.0	10.0	0.45
	On-board	0.501	0	10.0	0.06
5.2	Dish	0.004	24.0	10.0	0.09
	Patch Array	0.020	17.0	10.0	0.09
	On-board	0.251	0	10.0	0.04
5.4	Dish	0.004	24.0	10.0	0.09
	Patch Array	0.020	17.0	10.0	0.09
	On-board	0.501	0	10.0	0.06
5.8	Dish	0.501	24.0	10.0	1.00
	Patch Array	0.501	17.0	10.0	0.45
	On-board	0.501	0	10.0	0.06
6	Dish	0.016	24.0	10.0	0.18

Table 145: FCC minimum safe distances – PMP 450 MicroPoP APs 4.9 GHz, 5.1 GHz, 5.2 GHz, 5.4 GHz and 5.8 GHz

Band (GHz)	Antenna	P (W)	G (dBi)	S (W/ m2)	d (m)
4.9	Omni	0.501	9	10.0	0.18
	Sector	0.501	13	10.0	0.28
	Connectorized	0.501	(*)	10.0	(*)
5.1	Omni	0.501	9	10.0	0.18
	Sector	0.199	13	10.0	0.18
	Connectorized	(*)	(*)	10.0	0.18

Band (GHz)	Antenna	P (W)	G (dBi)	S (W/ m2)	d (m)
5.2	Omni	0.125	9	10.0	0.09
	Sector	0.050	13	10.0	0.09
	Connectorized	(*)	(*)	10.0	0.09
5.4	Omni	0.125	9	10.0	0.09
	Sector	0.050	13	10.0	0.09
	Connectorized	(*)	(*)	10.0	0.09
5.8	Omni	0.501	9	10.0.	0.18
	Sector	0.199	13	10.0	0.18
	Connectorized	(*)	(*)	10.0	0.18

(*) It depends on the external antenna gain

Table 146: FCC minimum safe distances – PMP/PTP 450b Retro APs 4.9 GHz, 5.1 GHz, 5.2 GHz, 5.4 GHz and 5.8 GHz

Band (GHz)	Antenna	P (W)	G (dBi)	S (W/ m2)	d (m)
4.9	Integrated	0.501	8	10.0	0.16
5.1	Integrated	0.501	8	10.0	0.16
5.2	Integrated	0.501	8	10.0	0.16
5.4	Integrated	0.501	8	10.0	0.16
5.8	Integrated	0.501	8	10.0	0.16

Table 147: FCC minimum safe distances – PMP/PTP 450i 900 MHz, 3.65 GHz, 4.9 GHz, 5.1 GHz, 5.2 GHz, 5.4 GHz and 5.8 GHz

Band	Antenna	P burst (W)	P (W)	G (dBi)	S (W/m ²)	d (m)
900 MHz	Sector antenna	-	0.19	22.75 (13 dBi)	6.0	0.27
3.65 GHz	90° sector antenna, integrated	-	0.316	50.0 (17 dBi)	10.0	0.36
		-	0.316	40.0 (16 dBi)	10.0	0.32

Band	Antenna	P burst (W)	P (W)	G (dBi)	S (W/m ²)	d (m)
	90° sector antenna, connectorized					
	Panel, integrated	-	0.251	79.0 (19 dBi)	10.0	0.40
4.9 GHz	Omni-directional	0.2138	0.2512	20.0 (13 dBi)	10.0	0.17
	90° sector antenna	0.2138	0.2512	50.0 (17 dBi)	10.0	0.26
	2ft directional flat plate	0.2138	0.2512	631.0 (28 dBi)	10.0	0.93
	4ft directional parabolic	0.851	0.1000	2344.0 (34.9 dBi)	10.0	1.14
	6ft directional parabolic	0.1413	0.1659	5248.0 (37.2 dBi)	10.0	2.19
5.1 GHz	Omni-directional	0.170	0.200	20.0 (13.0 dBi)	10.0	0.15
	90° sector	0.034	0.040	50.1 (17.0 dBi)	10.0	0.10
	2ft directional flat plate	0.002	0.002	707.9 (28.5 dBi)	10.0	0.09
	4ft directional parabolic	0.011	0.013	2818.4 (34.5 dBi)	10.0	0.44
5.2 GHz	Omni-directional	0.036	0.042	20.0 (13.0 dBi)	10.0	0.07
	90° sector	0.014	0.017	50.1 (17.0 dBi)	10.0	0.07
	2ft directional flat plate	0.001	0.001	707.9 (28.5 dBi)	10.0	0.07
	4ft directional parabolic	0.000	0.000	2818.4 (34.5 dBi)	10.0	0.06

Band	Antenna	P burst (W)	P (W)	G (dBi)	S (W/m ²)	d (m)
5.4 GHz	Omni-directional	0.036	0.042	20.0 (13.0 dBi)	10.0	0.07
	90° sector	0.014	0.017	50.1 (17.0 dBi)	10.0	0.07
	2ft directional flat plate	0.001	0.001	707.9 (28.5 dBi)	10.0	0.07
	2ft directional parabolic	0.001	0.001	707.9 (28.5 dBi)	10.0	0.08
5.8 GHz	Omni-directional	0.24	0.28	20.0 (13 dBi)	10.0	0.18
	90° sector	0.10	0.12	50.0 (17 dBi)	10.0	0.18
	2ft directional flat plate	0.54	0.63	708.0 (28.5 dBi)	10.0	1.57
	4ft directional parabolic	0.54	0.63	3388.0 (35.3 dBi)	10.0	3.43
	6ft directional parabolic	0.54	0.63	6457.0 (38.1 dBi)	10.0	4.74

Table 148: FCC minimum safe distances – PMP/PTP 450 900 MHz, 2.4 GHz, 3.65 GHz and 5 GHz

Band	Antenna	P burst (W)	G (dBi)	S (W/ m ²)	d (m)
900 MHz	Yagi	0.032	13 (11 dBi)	6.0	0.07
2.4 GHz	Sector Antenna	0.079	50 (17 dBi)	10.0	0.18
	Integrated	0.158	6 (8 dBi)	10.0	0.09
	Reflector	0.040	100 (20 dBi)	10.0	0.18
3.65 GHz	Sector Antenna	0.316	32 (15 dBi)	10.0	0.28
	Integrated	0.316	6 (8 dBi)	10.0	0.12
	Reflector	0.25	100 (20 dBi)	10.0	0.45
	High Gain Ruggedized	0.25	79 (19 dBi)	10.0	0.40
5.4 GHz	Sector	0.025	40 (16 dBi)	10.0	0.09
	Integrated	0.126	8 (9 dBi)	10.0	0.09
	Reflector	0.003	316 (25 dBi)	10.0	0.09
	CLIP	0.020	50 (17 dBi)	10.0	0.09
	LENS	0.032	28 (14.5 dBi)	10.0	0.08
	Integrated Dish (450d)	0.0032	316 (25 dBi)	10.0	0.09

Band	Antenna	P burst (W)	G (dBi)	S (W/ m ²)	d (m)
5.8 GHz	Sector	0.079	40 (16 dBi)	10.0	0.16
	Integrated	0.158	8 (9 dBi)	10.0	0.10
	Reflector	0.158	316 (25 dBi)	10.0	0.63
	CLIP	0.158	50 (17 dBi)	10.0	0.25
	LENS	0.158	28 (14.5 dBi)	10.0	0.19
	Integrated Dish (450d)	0.158	316 (25 dBi)	10.0	0.63

Table 149: FCC minimum safe distances – 450v AP 5.1 GHz, 5.8 GHz, and 6 GHz

Band (GHz)	Antenna	P (W)	G (dBi)	S (W/ m ²)	d (m)
5.1	Integrated	0.1	16	10	0.18
5.8	Integrated	0.1	16	10	0.18
6	Integrated	0.1	16	10	0.18

Table 150: FCC minimum safe distances – 450v 4x4 SM/BHS 5.1 GHz, 5.8 GHz, and 6 GHz

Band (GHz)	Antenna	P (W)	G (dBi)	S (W/ m ²)	d (m)
5.1	Dish	0.63	22	10	0.8
5.8	Dish	0.63	22	10	0.8
6	Dish	0.025	22	10	0.18

Table 151: FCC minimum safe distances – 450v 2x2 SM/BHS 5.1 GHz, 5.8 GHz, and 6 GHz

Band (GHz)	Antenna	P (W)	G (dBi)	S (W/ m ²)	d (m)
5.1	Dish	0.63	24	10	1.12
5.8	Dish	0.63	24	10	1.12
6	Dish	0.015	24	10	0.18

Table 152: ISEDC minimum safe distances – 450v 4x4 AP

Band (GHz)	Antenna	PG (W)	S (W/ m ²)	d (m)
5.1	Integrated	20	9.01	0.19
5.8	Integrated	20	9.69	0.18
6	Integrated	20	9.92	0.18

Table 153: ISED minimum safe distances – 450v 4x4 SM/BHS

Band (GHz)	Antenna	PG (W)	S (W/ m2)	d (m)
5.1	Dish	22	9.01	0.94
5.8	Dish	22	9.69	0.91
6	Dish	22	9.92	0.18

Table 154: ISED minimum safe distances – 450v 2x2 SM/BHS

Band (GHz)	Antenna	PG (W)	S (W/ m2)	d (m)
5.1	Dish	28	9.01	1.18
5.8	Dish	28	9.69	1.14
6	Dish	12	9.92	0.18

Table 155: ISED minimum safe distances – PMP 450m 3GHz and 5 GHz (4.9 GHz, 5.4 GHz and 5.8 GHz)

Band (GHz)	Antenna	PG (W)	S (W/ m2)	d (m)
3.45	90° sector	851	6.85	3.14
3.65	90° sector	536	6.83	2.5
3.9	90° sector	37.3	10	2.4
4.9	90° sector	174	8.75	1.16
5.4	90° sector	0.85	9.39	0.08
5.8	90° sector	3.38	9.83	0.17

Table 156: ISED minimum safe distances – PMP 450 MicroPoP APs 4.9 GHz, 5.1 GHz, 5.2 GHz, 5.4 GHz and 5.8 GHz

Band (GHz)	Antenna	P (W)	G (dBi)	S (W/ m2)	d (m)	S @ 20 cm (W/ m2)
4.9	Omni	0.501	9	8.71	0.18	7.92
	Sector	0.501	13	8.71	0.28	19.89
	Connectorized	0.501	(*)	8.71	(*)	(*)
5.1	Omni	0.501	9	9.01	0.17	7.92
	Sector	0.199	13	9.01	0.17	7.92
	Connectorized	(*)	(*)	9.01	0.17	7.92

Band (GHz)	Antenna	P (W)	G (dBi)	S (W/ m2)	d (m)	S @ 20 cm (W/ m2)
5.2	Omni	0.125	9	9.13	0.09	1.99
	Sector	0.050	13	9.13	0.09	1.99
	Connectorized	(*)	(*)	9.13	0.09	1.99
5.4	Omni	0.125	9	9.39	0.08	1.99
	Sector	0.050	13	9.39	0.08	1.99
	Connectorized	(*)	(*)	9.39	0.08	1.99
5.8	Omni	0.501	9	9.69	0.17	7.92
	Sector	0.199	13	9.69	0.17	7.92
	Connectorized	(*)	(*)	9.69	0.17	7.92

(*) It depends on the external antenna gain

Table 157: ISED minimum safe distances – PMP/PTP 450b Retro APs 4.9 GHz, 5.1 GHz, 5.2 GHz, 5.4 GHz and 5.8 GHz

Band (GHz)	Antenna	P (W)	G (dBi)	S (W/ m2)	d (m)	S @ 20 cm (W/ m2)
4.9	Integrated	0.501	8	8.71	0.16	6.29
5.1	Integrated	0.501	8	9.01	0.15	6.29
5.2	Integrated	0.501	8	9.13	0.15	6.29
5.4	Integrated	0.501	8	9.39	0.15	6.29
5.8	Integrated	0.501	8	9.69	0.15	6.29

Table 158: ISEDC minimum safe distances – PMP/PTP 450b 3.65 GHz, 4.9 GHz, 5.1 GHz, 5.2 GHz, 5.4 GHz, 5.8 GHz and 6 GHz

Band (GHz)	Antenna	P (W)	G (dBi)	S (W/ m2)	d (m)	S @ 20 cm (W/ m2)
3.65	Dish	6.15	20	6.72	0.27	12.0
3.9	Dish	3.35	20	7.37	0.19	7.37
4.9	Dish	0.501	24	8.76	1.07	250.5
	Patch Array	0.501	17	8.76	0.48	50.0
	On-board	0.501	0	8.76	0.07	1.0

Band (GHz)	Antenna	P (W)	G (dBi)	S (W/ m2)	d (m)	S @ 20 cm (W/ m2)
5.1	Dish	0.501	24	9.01	1.05	250.5
	Patch Array	0.501	17	9.01	0.47	50.0
	On-board	0.501	0	9.01	0.07	1.0
5.2	Dish	0.004	24	9.13	0.09	2.0
	Patch Array	0.020	17	9.13	0.09	2.0
	On-board	0.251	0	9.13	0.05	0.5
5.4	Dish	0.004	24	9.39	0.09	2.0
	Patch Array	0.020	17	9.39	0.09	2.0
	On-board	0.501	0	9.39	0.07	1.0
5.8	Dish	0.501	24	9.69	1.02	250.5
	Patch Array	0.501	17	9.69	0.45	50.0
	On-board	0.501	0	9.69	0.06	1.0
6	Dish	0.016	24	9.92	0.18	7.9

Table 159: ISED minimum safe distances – PMP/PTP 450i, 900 MHz, 3.5 GHz, 3.65 GHz, 4.9 GHz, 5.2 GHz, 5.4 GHz, and 5.8 GHz

Band	Antenna	P burst (W)	P (W)	G (dBi)	S (W/ m2)	d (m)
900 MHz	Sector	-	.02	20.0 (13 dBi)	2.74	0.11
3.5 GHz	90° sector antenna, integrated	-	0.316	50.0 (17 dBi)	6.99	0.39
	90° sector antenna, connectorized	-	0.316	40.0 (16 dBi)	6.99	0.35
	Panel, integrated	-	0.316	79.0 (19 dBi)	6.99	0.49
3.65 GHz (Lower Canada)	90° sector antenna, integrated	-	0.316	50.0 (17 dBi)	7.13	0.42
	90° sector antenna, connectorized	-	0.316	40.0 (16 dBi)	7.13	0.37
	Panel, integrated	-	0.251	79.0 (19 dBi)	7.13	0.47

Band	Antenna	P burst (W)	P (W)	G (dBi)	S (W/ m²)	d (m)
3.65 GHz (Upper Canada)	90° sector antenna, integrated	-	0.316	50.0 (17 dBi)	7.13	0.42
	90° sector antenna, connectorized	-	0.316	40.0 (16 dBi)	7.13	0.37
	Panel, integrated	-	0.251	79.0 (19 dBi)	7.13	0.47
4.9 GHz	Omni-directional	0.214	0.251	20.0 (13 dBi)	8.71	0.20
	90° sector	0.214	0.251	50.1 (17 dBi)	8.71	0.31
	2ft directional flat plate	0.214	0.251	631.0 (28 dBi)	8.71	1.11
	6ft directional parabolic	0.141	0.166	5248.0 (37.2 dBi)	8.71	2.60
5.2 GHz	Omni-directional	0.009	0.011	20.0 (13.0 dBi)	9.13	0.04
	90° sector	0.012	0.014	50.1 (17.0 dBi)	9.13	0.06
	2ft directional flat plate	0.001	0.001	707.9 (28.5 dBi)	9.13	0.07
	2ft directional parabolic	0.001	0.001	707.9 (28.5 dBi)	9.13	0.06
5.4 GHz	Omni-directional	0.036	0.042	20.0 (13.0 dBi)	9.39	0.07
	90° sector	0.014	0.017	50.1 (17.0 dBi)	9.39	0.07
	2ft directional flat plate	0.001	0.001	707.9 (28.5 dBi)	9.39	0.07
	2ft directional parabolic	0.001	0.001	707.9 (28.5 dBi)	9.39	0.06
5.8 GHz	Omni-directional	0.24	0.28	20.0 (13 dBi)	9.69	0.20
	90° sector	0.10	0.12	50.1 (17 dBi)	9.69	0.20
	2ft directional flat plate	0.54	0.63	707.9 (28.5 dBi)	9.69	1.67
	4ft directional parabolic	0.54	0.63	3388.4 (35.3 dBi)	9.69	4.82

Table 160: ISEDC minimum safe distance – PMP/PTP 450 900 MHz, 2.4 GHz, 3.5/3.65 GHz and 5 GHz

Band	Antenna	P burst (W)	G (dBi)	S (W/ m2)	d (m)
900 MHz	Yagi	0.316	13 (11 dBi)	2.74	0.35
2.4 GHz	Sector Antenna	0.079	50 (17 dBi)	5.35	0.24
	Integrated	0.158	6 (8 dBi)	5.35	0.12
	Reflector	0.040	100 (20 dBi)	5.35	0.24
3.5 GHz	Sector	0.316	32 (15 dBi)	37.10	0.15
	Integrated	0.316	6 (8 dBi)	37.10	0.06
	Reflector	0.316	100 (20 dBi)	37.10	0.26
	High Gain Ruggedized	0.316	79 (19 dBi)	37.10	0.23
3.65 GHz (lower Canada)	Sector	0.316	32 (15 dBi)	38.20	0.15
	Integrated	0.316	6 (8 dBi)	38.20	0.06
	Reflector	0.316	100 (20 dBi)	38.20	0.26
	High Gain Ruggedized	0.316	79 (19 dBi)	38.20	0.23
3.65 GHz (upper Canada)	Sector	0.316	32 (15 dBi)	38.20	0.14
	Integrated	0.316	6 (8 dBi)	38.20	0.06
	Reflector	0.20	100 (20 dBi)	38.20	0.20
	High Gain Ruggedized	0.003	79 (19 dBi)	38.20	0.23
5.4 GHz	Sector	0.025	40 (16 dBi)	9.39	0.09
	Integrated	0.126	8 (9 dBi)	9.39	0.09
	Reflector	0.003	316 (25 dBi)	9.39	0.09
	CLIP	0.020	50 (17 dBi)	9.39	0.09
	LENS	0.032	28 (14.5 dBi)	9.39	0.09
	Integrated Dish (450d)	0.0032	316 (25 dBi)	9.39	0.09
5.8 GHz	Sector	.079	40 (16 dBi)	9.69	0.16
	Integrated	0.158	8 (9 dBi)	9.69	0.10
	Reflector	0.158	316 (25 dBi)	9.69	0.064
	CLIP	0.158	50 (17 dBi)	9.69	0.25
	LENS	0.158	28 (14.5 dBi)	9.69	0.19
	Integrated Dish (450d)	0.158	316 (25 dBi)	9.69	0.64

(*1) P: maximum average transmit power capability of the radio including cable loss (Watt)



Note

Gain of antenna in dBi = $10 * \log(G)$.

The regulations require that the power used for the calculations is the maximum power in the transmit burst subject to allowance for source-based time-averaging.

At 5.4 GHz and EU 5.8 GHz, the products are generally limited to a fixed EIRP which can be achieved with the Integrated Antenna. The calculations above assume that the maximum EIRP allowed by the regulations is being transmitted.



Remarque

Gain de l'antenne en dBi = $10 * \log(G)$.

Les règlements exigent que la puissance utilisée pour les calculs soit la puissance maximale de la rafale de transmission soumis à une réduction pour prendre en compte le rapport cyclique pour les signaux modulés dans le temps.

Pour une opération dans la CEE dans les bandes 5,4 GHz et 5,8 GHz, les produits sont généralement limités à une PIRE qui peut être atteinte avec l'antenne intégrée. Les calculs ci-dessus supposent que la PIRE maximale autorisée par la réglementation est atteinte.



Note

If there are no EIRP limits in the country of deployment, use the distance calculations for FCC 5.8 GHz for all frequency bands.

At FCC 5.8 GHz, for antennas between 0.6m (2ft) and 1.8m (6ft), alter the distance proportionally to the antenna gain.



Remarque

Si aucune limite de PIRE existe pour le pays de déploiement, utilisez les calculs de distance pour FCC 5,8 GHz pour toutes les bandes de fréquence.

Pour la band FCC 5,8 GHz et les antennes entre 0,6 m (2 pieds) et 1,8 m (6 pieds), modifier la distance proportionnellement au gain de l'antenne.

Capacité de puissance d'émission moyenne maximale de la radio comprenant la perte dans les câble de connexion (W)

(*2) G: total transmit gain as a factor, converted from dB

Gain total d'émission, converti à partir de la valeur en dB

(*3) S: power density (W/m^2)

Densité de puissance (W/m^2)

(*4) d: minimum distance from point source (meters)

Distance minimale de source ponctuelle (en mètres)

Tx power limits for PMP 450 MicroPoP

The PMP 450 MicroPoP uses the same FCC grant as the PMP 450b mid-gain. The Tx power limits are captured as shown below. Omni antenna gain = 8 dBi; Sector antenna gain = 13 dBi

	5/10 MHz			MicroPoP Connectorized	20/40 MHz			MicroPoP Connectorized
	Rounded EIRP	MicroPoP Omni Tx power	MicroPoP Sector Tx power		Rounded EIRP	MicroPoP Omni Tx power	MicroPoP Sector Tx power	
4.9 GHz		26 dBm	26 dBm	26 dBm		24 dBm	24 dBm	24 dBm
5.1 GHz	26 dBm	17 dBm	13 dBm	EIRP – Antenna Gain	32 dBm	23 dBm	19 dBm	EIRP – Antenna Gain
5.2 GHz	25 dBm	16 dBm	12 dBm	EIRP – Antenna Gain	25 dBm	16 dBm	12 dBm	EIRP – Antenna Gain
5.4 GHz	25 dBm	16 dBm	12 dBm	EIRP – Antenna Gain	25 dBm	16 dBm	12 dBm	EIRP – Antenna Gain
5.8 GHz	32 dBm	23 dBm	19 dBm	EIRP – Antenna Gain	31 dBm	22 dBm	18 dBm	EIRP – Antenna Gain

Hazardous location compliance

The PMP/PTP 450i series IECEx/ATEX/HAZLOC ODUs have been certified for operation in the following hazardous locations:

ATEX

The products have been approved under an “Intrinsic Safety” assessment as defined in EN60079-11:2012.

The approval is given by certificate number EMT126ATEX0003X, issued by Element Materials Technology, with the specific level of coverage shown below:

- II 3 G Ex ic IIC T4
- II - Equipment group (surface applications)
- 3 - Equipment category (infrequent exposure)
- G - Atmosphere (Gas)
- ic - Protection concept (intrinsic safety)
- IIC - Gas group (up to and including Hydrogen and Acetylene)
- T4 - Temperature class (135°C)

IECEX approvals - Certificate No, IECEX EMT 16.0001X

Marking - Ex ic IIC T4 Gc Tamb -40C to + 60C

Chapter 7: Compliance with radio regulations

This section describes how the 450 Platform Family complies with the radio regulations that are in force in various countries.



Caution

Where necessary, the end user is responsible for obtaining any National licenses required to operate this product and these must be obtained before using the product in any country. Contact the appropriate national administrations for details of the conditions of use for the bands in question and any exceptions that might apply.



Caution

Changes or modifications not expressly approved by Cambium Networks could void the user's authority to operate the system.



Caution

For the connectorized version of the product and in order to reduce potential radio interference to other users, the antenna type and its gain should be so chosen that the Effective Isotropically Radiated Power (EIRP) is not more than that permitted for successful communication.



Attention

Le cas échéant, l'utilisateur final est responsable de l'obtention des licences nationales nécessaires pour faire fonctionner ce produit. Celles-ci doivent être obtenus avant d'utiliser le produit dans un pays particulier. Contactez les administrations nationales concernées pour les détails des conditions d'utilisation des bandes en question, et toutes les exceptions qui pourraient s'appliquer



Attention

Les changements ou modifications non expressément approuvés par les réseaux de Cambium pourraient annuler l'autorité de l'utilisateur à faire fonctionner le système.



Attention

Pour la version du produit avec une antenne externe, et afin de réduire le risque d'interférence avec d'autres utilisateurs, le type d'antenne et son gain doivent être choisis afin que la puissance isotrope rayonnée équivalente (PIRE) ne soit pas supérieure au minimum nécessaire pour établir une liaison de la qualité requise.

Type approvals

This system has achieved Type Approval in various countries around the world. This means that the system has been tested against various local technical regulations and found to comply. The frequency bands in

which the system operates may be ‘unlicensed’ and, in these bands, the system can be used provided it does not cause interference. The system is not guaranteed protection against interference from other products and installations.

The radio specification type approvals that have been granted for 450 Platform Family frequency variants are listed under [Radio certifications](#).

Table 161: Radio certifications

Region/Country	Band	Specification
Brazil	4.9 GHz	ANATEL, RESOLUÇÃO N° 633, DE 14 DE MARÇO DE 2014
	5.4 GHz	ANATEL, RESOLUTION No. 506, FROM JULY 1, 2008
	5.8 GHz	ANATEL, RESOLUTION No. 506, FROM JULY 1, 2008
Mexico	900 MHz	NOM-121-SCT1-2009
	4.9 GHz	Protocol Between the UNITED STATES OF AMERICA and MEXICO – Use of 4940 to 4990 MHz band.
	5.4 GHz	Acuerdo del 27 de noviembre de 2012
	5.8 GHz	NOM-121-SCT1-2009
USA	900 MHz	FCC Part 15.247, FCC Part 15 Class B
	2.4 GHz	FCC Part 15.247, FCC Part 15 Class B
	3.6 GHz	FCC Part 96, FCC Part 15 Class B
	4.9 GHz	FCC 47 CFR Part 90, FCC Part 15 Class B
	5.1 GHz	FCC 47 CFR Part 15 E, FCC Part 15 Class B
	5.2 GHz	FCC 47 CFR Part 15 E, FCC Part 15 Class B
	5.4 GHz	FCC 47 CFR Part 15 E, FCC Part 15 Class B
	5.8 GHz	FCC 47 CFR Part 15 E
Canada	900 MHz	RSS Gen and RSS 210
	2.4 GHz	RSS Gen and RSS 210
	3.5 /3.6/3.95 GHz	RSS Gen, RSS-197, RSS 192 and RSS 198
	4.9 GHz	IC RSS-111, Issue 5
	5.8 GHz	IC RSS-247, Issue 2
Europe	3.5 GHz	ETSI EN 302 326-2 V1.2.2
	5.4 GHz	ETSI EN 301 893 V2.1.1
	5.8 GHz	ETSI EN 302 502 V2.1.1

Brazil specific information

Brazil notification

For compliant operation in the 5.4 GHz band, the Equivalent Isotropic Radiated Power from the integrated antenna or connectorized antenna shall not exceed 30 dBm (0.5 W).

The operator is responsible for enabling the DFS feature on any Canopy 5.4 GHz radio by setting the Country Code to “Brazil”, including after the module is reset to factory defaults.

Important Note: This equipment operates as a secondary application, so it has no rights against harmful interference, even if generated by similar equipment, and cannot cause harmful interference on systems operating as primary applications.

Brazil certification numbers

The Anatel certification number for Brazil for the PMP/PTP 450i Series is 2426-15-7745.

Australia Notification

900 MHz modules must be set to transmit and receive only on center channels of 920, 922, or 923 MHz to stay within the ACMA approved band of 915 MHz to 928 MHz for the class license and not interfere with other approved users.

After considering antenna gain (in dBi), 900 MHz modules' transmitter output power (in dBm) must be set to stay within the legal regulatory limit of 30 dBm (1 W) EIRP for this 900 MHz frequency band.

Regulatory Requirements for CEPT Member States (www.cept.org)

When operated in accordance with the instructions for use, Cambium Wireless equipment operating in the 5.1 GHz and 5.4 GHz bands is compliant with CEPT Resolution 229 (REV. WRC-12).

Operating the 450 Platform Family in the bands 5150 to 5350 MHz and 5470 to 5725 MHz is granted providing it is not causing interference to the existing primary services allocated to those bands.

For compliant operation in the 5250 to 5350 MHz band, the transmit power from the integrated antenna or a connectorized antenna shall be limited to a maximum mean EIRP of 200 mW and a maximum mean EIRP density of 10 mW/MHz in any 1 MHz band.

For compliant operation in the 5470 to 5725 MHz band, the transmit power shall be restricted to a maximum of 250 mW with a maximum mean EIRP of 1 W and a maximum mean EIRP density of 50 mW/MHz in any 1 MHz band.

For compliant operation in the bands 5 250-5 350 MHz and 5 470-5 725 MHz, the 450 Platform Family employs transmitter power control (TCP) and Dynamic Frequency Selection (DFS).

For EU member states, RLAN equipment in the 5.4GHz bands is exempt from individual licensing under Commission Recommendation 2003/203/EC. Contact the appropriate national administrations for details on the conditions of use for the bands in question and any exceptions that might apply. Also see www.ero.dk for further information.

Cambium Radio equipment operating in the 5470 to 5725 MHz band are categorized as “Class 1” devices within the EU in accordance with ECC DEC(04)08 and are “CE” marked to show compliance with the European Radio Equipment Directive (RED) 2014/53/EU. The relevant Declaration of Conformity can be found at http://www.cambiumnetworks.com/ec_dofc/.

Canadian Installation Procedures (900 MHz 450i)

1. << En effet, il est conçu pour être approvisionné par un bloc d'alimentation PoE listé UL et portant la mention <<LPS>> ou <<PS2 complied>>.

2. Encapsulé dans un boîtier de type 450i, il comporte 450 circuits qui sont obligatoirement alimentés par 30V dc.

3. La prise de type RJ-11 est utilisée par une personne qualifiée uniquement pour la connexion GPS et aucun raccordement au système de télécommunication n'est nécessaire.