



# INSTALLATION GUIDE

## **PTP 850CX**

Release 13.1



## **Reservation of Rights**

Cambium reserves the right to make changes to any products described herein to improve reliability, function, or design, and reserves the right to revise this document and to make changes from time to time in content hereof with no obligation to notify any person of revisions or changes. Cambium recommends reviewing the Cambium Networks website for the latest changes and updates to products. Cambium does not assume any liability arising out of the application or use of any product, software, or circuit described herein; neither does it convey license under its patent rights or the rights of others. It is possible that this publication may contain references to, or information about Cambium products (machines and programs), programming, or services that are not announced in your country. Such references or information must not be construed to mean that Cambium intends to announce such Cambium products, programming, or services in your country.

## **Copyrights**

This document, Cambium products, and 3<sup>rd</sup> Party software products described in this document may include or describe copyrighted Cambium and other 3<sup>rd</sup> Party supplied computer programs stored in semiconductor memories or other media. Laws in the United States and other countries preserve for Cambium, its licensors, and other 3<sup>rd</sup> Party supplied software certain exclusive rights for copyrighted material, including the exclusive right to copy, reproduce in any form, distribute and make derivative works of the copyrighted material. Accordingly, any copyrighted material of Cambium, its licensors, or the 3<sup>rd</sup> Party software supplied material contained in the Cambium products described in this document may not be copied, reproduced, reverse engineered, distributed, merged or modified in any manner without the express written permission of Cambium. Furthermore, the purchase of Cambium products shall not be deemed to grant either directly or by implication, estoppel, or otherwise, any license under the copyrights, patents or patent applications of Cambium or other 3<sup>rd</sup> Party supplied software, except for the normal non-exclusive, royalty free license to use that arises by operation of law in the sale of a product.

## **Restrictions**

Software and documentation are copyrighted materials. Making unauthorized copies is prohibited by law. No part of the software or documentation may be reproduced, transmitted, transcribed, stored in a retrieval system, or translated into any language or computer language, in any form or by any means, without prior written permission of Cambium.

## **License Agreements**

The software described in this document is the property of Cambium and its licensors. It is furnished by express license agreement only and may be used only in accordance with the terms of such an agreement.

## **High Risk Materials**

Cambium and its supplier(s) specifically disclaim any express or implied warranty of fitness for any high-risk activities or uses of its products including, but not limited to, the operation of nuclear facilities, aircraft navigation or aircraft communication systems, air traffic control, life support, or weapons systems (“High Risk Use”).

This product is not restricted in the EU. Any High Risk is unauthorized, is made at your own risk and you shall be responsible for any and all losses, damage or claims arising out of any High-Risk Use.

© 2026 Cambium Networks Limited. All rights reserved

# Contents

---

<b>Contents</b> .....	<b>3</b>
<b>Before You Start</b> .....	<b>7</b>
Important Notes .....	7
Safety Precautions & Declared Material .....	7
Public and Occupational Boundary Distances Under Article 3.1(a) of the RE Directive .....	7
General Equipment Precautions .....	8
Précautions générales relatives à l'équipement .....	9
Allgemeine Vorsichtsmaßnahmen für die Anlage .....	9
Pre-Installation Instructions .....	10
Packing .....	10
Transportation and Storage .....	10
Unpacking .....	10
Inspection .....	10
<b>Product Hardware Description</b> .....	<b>11</b>
PTP 850CX Unit Description and Interfaces .....	11
Marketing Models for PTP 850CX Radio and Diplexer Units .....	12
Marketing Models for Easy Set PTP 850CX Radio and Diplexer Units, 6 to 11 GHz .....	13
Marketing Model for PTP 850CX Unit, 13-42 GHz .....	14
MultiCore Mediation Devices (MCMD) .....	14
PoE Injector .....	15
PoE Injector Interfaces .....	16
System Components .....	17
Adaptors and Installation Kits .....	20
Antenna Connection .....	24
Power Specifications .....	25
Electrical Requirements .....	25
Important Notes! .....	25
Environmental Specifications .....	25
<b>Cable Installation and Grounding</b> .....	<b>26</b>
Minimum and Maximum Cable Diameter .....	26
Grounding the Cables .....	26

---

<b>Grounding the PTP 850CX Unit</b> .....	<b>31</b>
Power Source .....	32
Surge Protection .....	33
Available Cable Options .....	34
Fiber Optic Cables - Single Mode .....	34
Fiber Optic Cables - Multi Mode .....	34
DC Cable and Connector .....	35
Cables for Layer 1 Link Aggregation Configurations .....	35
Ethernet Cable and Specifications .....	35
Outdoor Ethernet Cable Specifications .....	37
Outdoor DC Cable Specifications .....	38
Securing the Cables .....	38
Special Instructions for use of Glands .....	39
General Installation Procedure .....	40
Connecting an Optical Fiber Cable and SFP .....	45
Connecting a DC Power Cable .....	50
Connecting the Ethernet Cable .....	54
Preparing the Ethernet Cable and Plug-in Field .....	54
Preparing the Ethernet Cable Already Assembled .....	57
Connection of Ethernet Cable to PTP 850CX .....	58
Management Connection for 1+1/2+2 HSB Configurations .....	60
Preparing a Protection Signaling Cable .....	60
Connecting the Protection Splitters and Protection Signaling Cable .....	61
<b>PoE Injector Installation and Connection</b> .....	<b>63</b>
PoE Injector Cable Connection .....	63
PoE Injector Grounding .....	63
PoE Injector Wall Mount Installation .....	64
PoE Injector Pole Mount Installation .....	66
PoE Injector 19" Rack Installation .....	67
PoE Injector ETSI Rack Installation .....	68
<b>Generic Installation Procedures</b> .....	<b>70</b>
General Notes Concerning All Installation Procedures .....	70
XPIC-Ready 1+0 Links .....	70

---

Torque Requirements .....	71
Installing the Diplexer Unit on the Radio .....	71
PTP 850CX DC Pole Mount Procedure .....	75
Remote Mount Installation for Single Polarization with an Imperial Waveguide .....	77
13GHz Installation Procedure .....	77
15-23 GHz Installation Procedure .....	80
<b>Installation Procedures per Configuration Type .....</b>	<b>82</b>
2+0 Dual Polarization Direct Mount .....	82
2+0 Dual Polarization Remote Mount .....	83
2+0 Single Polarization Direct Mount .....	88
2+0 Single Polarization Remote Mount .....	90
4+0 Layer 1 Link Aggregation, Direct Mount .....	95
4+0 Layer 1 Link Aggregation, Remote Mount .....	98
2+2 HSB or 2 x 2+0 Dual Polarization Direct Mount .....	102
2+2 HSB Dual Polarization Remote Mount .....	105
2+2 HSB Single Polarization Direct Mount .....	112
2+2 HSB Single Polarization Remote Mount .....	115
2 x 2+0 Dual Polarization Direct Mount .....	122
2 x 2+0 Dual Polarization Remote Mount .....	124
2 x 2+0 Single Polarization Direct Mount .....	131
4+0 Dual Polarization, 2+2 HSB Single/Dual Polarization Direct Mount .....	133
4+0 Dual Polarization, 2+2 HSB Dual Polarization Remote Mount .....	135
2+2 HSB Single Polarization Remote Mount .....	141
1+1 HSB-SD .....	146
<b>Installing PTP 850CX on Third-Party Antenna Adaptors .....</b>	<b>153</b>
Special Note on Converting ValuLine 3 Antennas .....	154
<b>Appendix A: Acceptance &amp; Commissioning Procedures .....</b>	<b>156</b>
Site Acceptance Procedure .....	156
Site Acceptance Checklist Notes .....	159
Radio Link Commissioning Procedure .....	160
Scope .....	160
Commissioning Test .....	161
PTP 850CX Commissioning Log .....	162

---

<b>Cambium Networks</b> .....	<b>165</b>
-------------------------------	------------

# Before You Start

---

## Important Notes

- For the warranty to be honored, install the unit in accordance with the instructions in this manual.
- Any changes or modifications of equipment not expressly approved by the manufacturer could void the user's authority to operate the equipment and the warranty for such equipment.
- PTP 850CX is intended for installation in a restricted access location.
- PTP 850CX must be installed and permanently connected to protective earth by qualified service personnel in accordance with applicable national electrical codes.
- Site grounding is the responsibility of the operator or owner of the site. It is critical that all site components be properly grounded in accordance with the specific site requirements and applicable industry standards and best practices. Ground resistance must be no more than 5 ohms. Any higher resistance may lead to equipment malfunction and affect the product's warranty.

## Safety Precautions & Declared Material

### Public and Occupational Boundary Distances Under Article 3.1(a) of the RE Directive

Based on the highest nominal output power of the PTP 850CX:

- The public exposure of compliance boundary distance is 4.1m. This is the worst case for the highest nominal output power, using 11GHz frequency band antennas up to 3 feet, using 13GHz frequency band antennas up to 2 feet, and using 6-8, 15-26, and 38GHz frequency bands and antennas up to 1 feet. For all other configurations, the compliance boundary distance is 0.
- The occupational exposure of compliance boundary distance is 0.5m. This is the worst case for the highest nominal output power, using 11/13 GHz frequency bands and antennas up to 1 ft. For all other configurations, the compliance boundary distance is 0.



**Note:**

Even when the compliance boundary is a non-zero value, this only applies within the bore sight of the antenna dish. Therefore, during work within and close to the front of the antenna, make sure the transmitters are turned off. As long as the transmitters are turned off during any work on the system, the occupational exposure limit is not of concern to workers operating in or around the parabolic dish antenna.

## General Equipment Precautions



**Warning:**

To avoid malfunctioning or personnel injuries, equipment or accessories/kits/plug-in unit installation, requires qualified and trained personnel. Changes or modifications not expressly approved by Cambium Networks could void the user's authority to operate the equipment.



**Warning:**

Where special cables, shields, adapters and grounding kits are supplied or described in this manual, these items must be used, to comply with the FCC regulations.



**Warning:**

Use of controls, adjustments, or performing procedures other than those specified herein, may result in hazardous radiation exposure.



**Warning:**

When working with an PTP 850CX, note the following risk of electric shock and energy hazard:  
Disconnecting one power supply disconnects only one power supply module. To isolate the unit completely, disconnect all power supplies.



**Warning:**

Machine noise information order - 3. GPSGV, the highest sound pressure level amounts to 70 dB (A) or less, in accordance with ISO EN 7779.



**Warning:**

In Norway and Sweden:

- Equipment connected to the protective earthing of the building installation through the mains connection or through other equipment with a connection to protective earthing – and to a cable distribution system using coaxial cable, may in some circumstances create a fire hazard. Connection to a cable distribution system has therefore to be provided through a device providing electrical isolation below a certain frequency range (galvanic isolator, see EN 60728-11).
- Utstyr som er koplet til beskyttelsesjord via nettplugg og/eller via annet jordtilkoplede utstyr – og er tilkoplede et kabel-TV nett, kan forårsake brannfare. For å unngå dette skal det ved tilkopling av utstyret til kabel-TV nettet installeres en galvanisk isolator mellom utstyret og kabel-TV nettet.
- Utrustning som är kopplad till skyddsjord via jordat vägguttag och/eller via annan utrustning och samtidigt är kopplad till kabel-TV nät kan i vissa fall medföra risk för brand. För att undvika detta skall vid anslutning av utrustningen till kabel-TV nät galvanisk isolator finnas mellan utrustningen och kabel-TV nätet.

**Caution:**

Static electricity may cause body harm, as well as harm to electronic components inside the device. Anyone responsible for the installation or maintenance of the PTP 850E must use an ESD Wrist Strap. ESD protection measures must be observed when touching the unit. To prevent damage, before touching components inside the device, all electrostatic must be discharged from both personnel and tools.

## Précautions générales relatives à l'équipement

**AVERTISSEMENT :**

L'utilisation de commandes ou de réglages ou l'exécution de procédures autres que celles spécifiées dans les présentes peut engendrer une exposition dangereuse aux rayonnements.

**AVERTISSEMENT :**

L'usage de PTP 850E s'accompagne du risque suivant d'électrocution et de danger électrique: le débranchement d'une alimentation électrique ne déconnecte qu'un module d'alimentation électrique. Pour isoler complètement l'unité, il faut débrancher toutes les alimentations électriques.

**AVERTISSEMENT :**

Bruit de machine d'ordre - 3. GPSGV, le plus haut niveau de pression sonore s'élève à 70 dB (A) au maximum, dans le respect de la norme ISO EN 7779.

## Allgemeine Vorsichtsmaßnahmen für die Anlage

**WARNUNG:**

Wenn andere Steuerelemente verwendet, Einstellungen vorgenommen oder Verfahren durchgeführt werden als die hier angegebenen, kann dies gefährliche Strahlung verursachen.

**WARNUNG:**

Beachten Sie beim Arbeiten mit PTP 850E das folgende Stromschlag- und Gefahrenrisiko: Durch Abtrennen einer Stromquelle wird nur ein

**WARNUNG:**

Stromversorgungsmodul abgetrennt. Um die Einheit vollständig zu isolieren, trennen Sie alle Stromversorgungen ab.

Maschinenlärminformations-Verordnung - 3. GPSGV, der höchste Schalldruckpegel beträgt 70 dB(A) oder weniger gemäß EN ISO 7779.

# Pre-Installation Instructions

## Packing

The equipment should be packed and sealed in moisture absorbing bags.

## Transportation and Storage

The equipment cases are prepared for shipment by air, truck, railway and sea, suitable for handling by forklift trucks and slings. The cargo must be kept dry during transportation, in accordance with ETS 300 019-1-2, Class 2.3. For sea-transport, deck-side shipment is not permitted. Carrier-owned cargo containers should be used.

It is recommended that the equipment be transported to the installation site in its original packing case.

If intermediate storage is required, the packed equipment must be stored in a dry and cool environment, and out of direct sunlight, in accordance with ETS 300 019-1-1, Class 1.2.

## Unpacking

The equipment is packed in sealed plastic bags and moisture absorbing bags are inserted. Any separate sensitive product, i.e. printed boards, are packed in anti-static handling bags. The equipment is further packed in special designed cases.

Marking is done according to standard practice unless otherwise specified by customers. The following details should be marked:

- Customers address
- Contract No
- Site name (if known)
- Case No

## Inspection

Check the packing lists and ensure that correct parts numbers quantities of goods have arrived. Inspect for any damage on the cases and equipment. Report any damage or discrepancy to a Cambium representative, by e-mail or fax.

# Product Hardware Description

## PTP 850CX Unit Description and Interfaces

PTP 850CX features an all-outdoor MultiCore architecture consisting of a single unit directly mounted on the antenna. The PTP 850CX combines full system capabilities with a very compact form-fit. The all outdoor system architecture is designed around Cambium’s IP core components, enabling a true MultiCore design.



**Note:**

The equipment is type approved and labeled according to RED (2014/53/EU).

PTP 850CX, Port 2 is the upper port, located closest to the handle, and Port 1 is the lower port, located closest to the Ethernet ports.

**Figure 1:** PTP 850CX Rear View (Left) and Front View (Right)

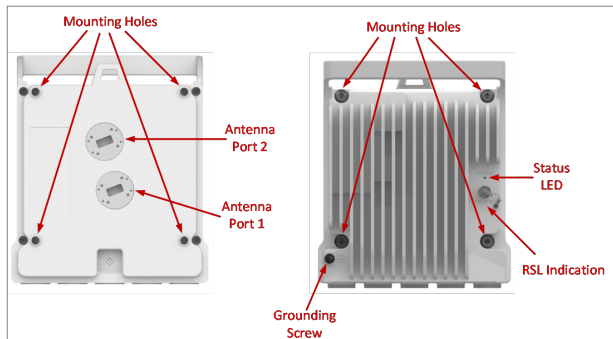

For traffic, the PTP 850CX has an RJ-45 interface (P2), an SFP+ cage (P3), and an SFP28 cage (P4). The PTP 850CX also has an RJ-45 management port (P5).

For power, the PTP 850CX has a DC power interface (-48V) (P1).

**Figure 2:** PTP 850CX Interfaces

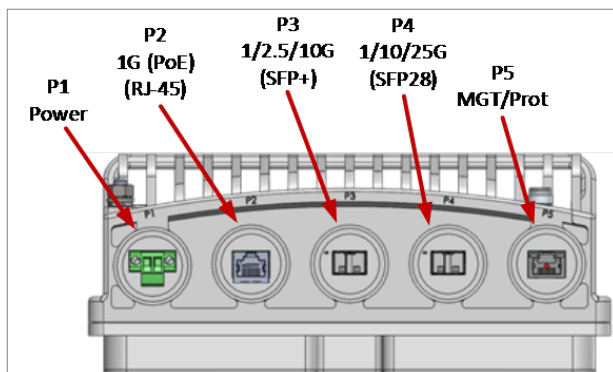

- Port 1 – Power Interface (-48V)
- Port 2 (Eth 1):

- RJ-45: 1000BASE-T
- PoE
- Port 3 (Eth 2):
  - SFP cage which supports SFP+ standard
  - Electric: 1000BASE-T
  - Optical: 1000BASE-X, 10GBASE-X
  - Optical: 1/2.5/10G
- Port 4 (Eth 3):
  - SFP cage which supports SFP28 standard
  - Electric: 1000BASE-T
  - Optical: 1000BASE-X, 10GBASE-X, 25GBASE-X
- Port 5:
  - RJ-45: 100BASE-T
  - Management and Protection port
- 2 RF Interfaces: Standard interface per frequency band
- RSL interface: BNC connector
- Grounding screw



**Note:**

Some limitations on supported interface usage and speed may exist. For details, refer to the Release Notes or Technical Description for the System Release version you are using

## Marketing Models for PTP 850CX Radio and Diplexer Units

For frequencies of 6 to 11 GHz, PTP 850CX uses the Easy Set technology in which two individual units are ordered: a generic radio unit and a diplexer unit.

For frequencies of 13 to 42 GHz, a single PTP 850CX unit is ordered, consisting of both the radio and the diplexers.

This section explains how to read PTP 850CX marketing models, including marketing models for the diplexer unit for 6-11 GHz links. Constructing a marketing model for the purpose of ordering equipment should always be done using a configurator.



**Note:**

Not all fields are always necessary to define a valid marketing model. If a specific field is not applicable, it should be omitted.

# Marketing Models for Easy Set PTP 850CX Radio and Diplexer Units, 6 to 11 GHz

For frequencies of 6 to 11 GHz, the PTP 850CX radio unit and diplexer unit are ordered separately. Using Easy Set technology, the diplexer unit is assembled on the PTP 850CX radio unit during link installation in the field. The radio unit is generic; only the diplexer unit (DXU) is sub-band specific, which facilitates link planning, ordering, and maintenance as described above.

[Table 1](#) provides the marketing model syntax for the PTP 850CX Easy Set radio unit.

[Table 2](#) provides the marketing model syntax for the PTP 850CX Easy Set diplexer unit.

**Table 1** PTP 850CX Marketing Model Syntax, 6 to 11 GHz (Radio Unit)

Marketing Model	Description
PTP 850CX-ff	PTP 850CX, Multicore ff GHz, All-Outdoor, Basic Radio

**Table 2** PTP 850CX Marketing Model Syntax, 6 to 11 GHz (Diplexer Unit)

Marketing Model	Description
DXCff-xxxY-ccWdd-t	Diplexers Unit, ff GHz, Block xxxY, ccWdd, High/Low

**Table 3** PTP 850CX Marketing Model Structure– Possible Values (Easy Set - Radio Unit Only)

Placeholder in Marketing Model	Description	Possible Values
ff	Frequency band	06,07,08,10,11

**Table 4** PTP 850CX Marketing Model Structure– Possible Values (Easy Set - Diplexer Unit Only)

Placeholder in Marketing Model	Description	Possible Values
ff	Frequency band	L6,U6,07,08,10,11
xxxY	TX-RX separation and block indication (Cambium internal)	xxx - TRS 3 figures in [MHz]. Y - Letter to indicate frequency block. Example: 266A  The frequency block is a Cambium internal parameter which defines different channelization using the same TRS and frequency band.
ccWdd	Channel indication or LOW/HIGH or blank	{Start ch}W{End ch} Example: 10W15
t	TX low / TX high indication	L – TX Low H – TX high

[Table 5](#) provides examples of specific PTP 850CX diplexer unit marketing models based on the syntax described above.

**Table 5** PTP 850CX Diplexer Unit Marketing Model Examples

Marketing Model Example	Explanation
DXCXL6-252A-01W04-L	PTP 850CX Diplexer Unit, Lower 6 GHz, TRS block 252A, Ch 1 to 4, Tx low
DXCX11-500-07W13-H	PTP 850CX Diplexer Unit, 11 GHz, TRS block 500, Ch 7 to 13, Tx high

## Marketing Model for PTP 850CX Unit, 13-42 GHz

When ordering an PTP 850CX, a single unit is ordered as a single unit. The following PTP 850CX hardware models are available.

**Table 6** PTP 850CX Marketing Models

Marketing Model	TX Range	RX Range
PTP 850CX-E-13-266-1W4-H	13002-13141	12745.75-12866
PTP 850CX-E-13-266-1W4-L	12745.75-12866	13002-13141
PTP 850CX-E-15-420-1W8-H	14921-15145	14501-14725
PTP 850CX-E-15-420-1W8-L	14501-14725	14921-15145
PTP 850CX-E-18-H-H	19160-19700	18126-18690
PTP 850CX-E-18-H-L	18126-18690	19160-19700
PTP 850CX-E-23-H	23000-23600	22000-22600
PTP 850CX-E-23-L	22000-22600	23000-23600

For availability of other frequencies, check with your Cambium representative.

## MultiCore Mediation Devices (MCMD)

The MultiCore Mediation Devices (MCMD) are designed to offer a simple and compact solution for a direct mount installation of the dual-carrier PTP 850CX on a standard RFU-C antenna.

PTP 850CX is equipped with two antenna ports, which mandates the use of the following MCMDs for direct mount connections. The specific MCMDs depend on the configuration.

The following describes some of the available MCMDs. For a full list of components, refer to [System Components](#).



**Note:**  
MCMDs are not grounded. In order to add grounding, the MCMD can be connected to the PTP 850CX using a Grounding Jumper.

**Table 7** MCMD Comparison

MCMD type	Functionality
Splitter	Combines the two carriers using the same polarization
OMT	Combines the two carriers on alternate polarizations (H,V)

**Figure 3:** Splitter

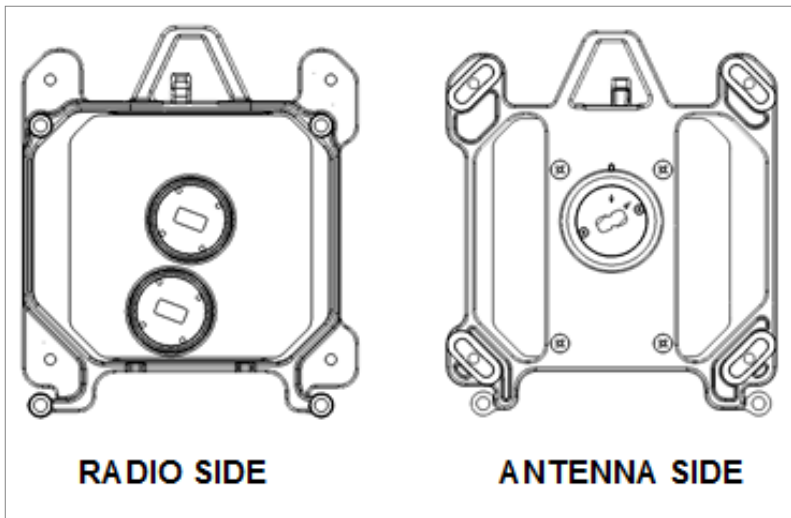

**Figure 4:** OMT

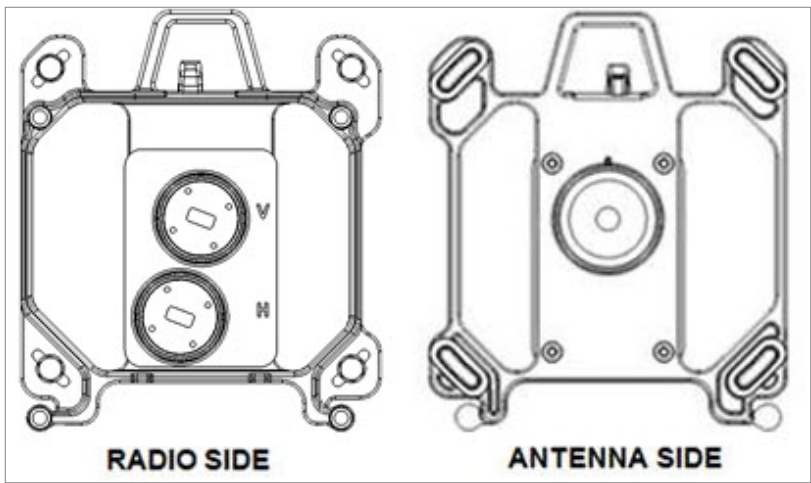

## PoE Injector

The PoE injector is an outdoor unit which can be mounted on a wall, pole, or indoor rack.

Each PoE Injector kit includes the following items:

- PoE injector
- 2 DC power connectors

**Figure 5:** *PoE Injector*

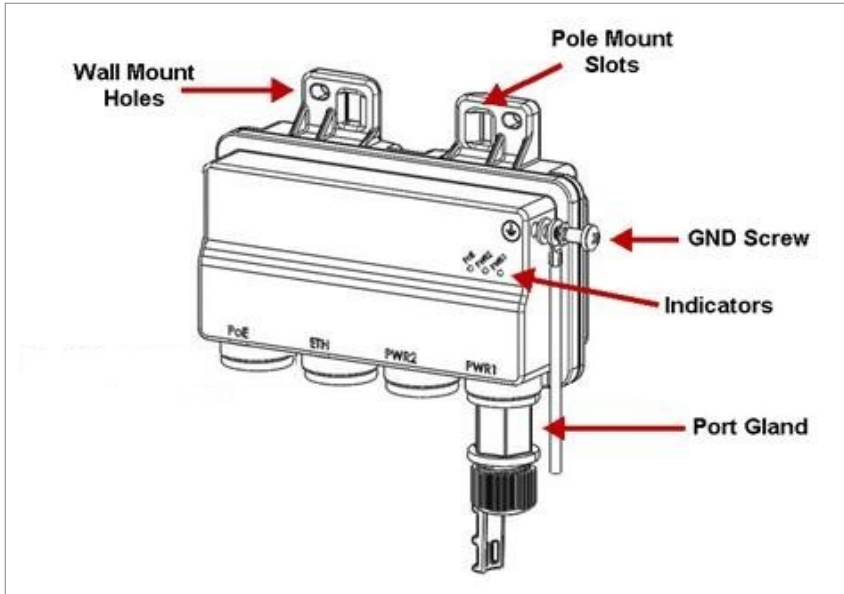

The following PoE Injector model is available:

- **PoE\_Inj\_AO\_2DC\_24V\_48V** – Includes two DC power ports with power input ranges of -(18-60)V each.

## PoE Injector Interfaces

- Power-Over-Ethernet (PoE) Port
- GbE Data Port supporting 10/100/1000Base-T
- DC Power Port 1 -(18-60)V or -(40-60)V
- DC Power Port 2 -(18-60)V
- Grounding screw

**Figure 6:** *PoE Injector Ports*

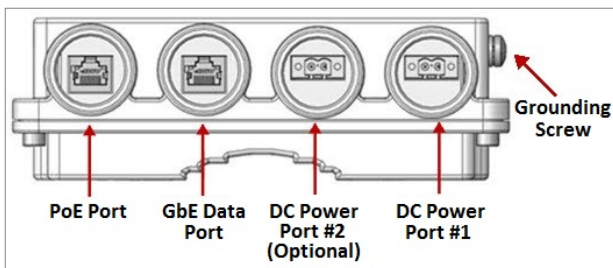

# System Components

The following figures show the main components used in the PTP 850CX installation procedures.



**Note:**

The availability of the installation components follows the PTP 850CX frequency rollout as stated in the published roadmap.

The presence of a specific component in this manual does not indicate that it is available for ordering. Please consult with your respective pre-sales engineer for specific component availability.

**Figure 7:** PTP 850CX

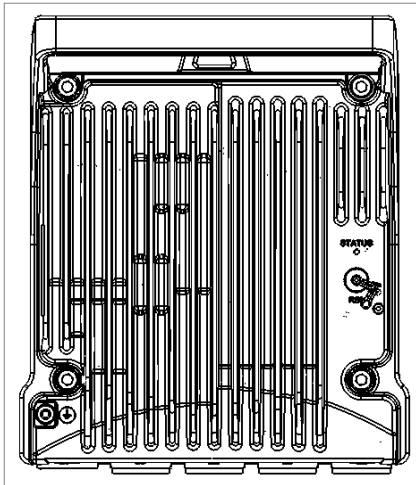

**Figure 8:** Dual Core Coupler/Splitter

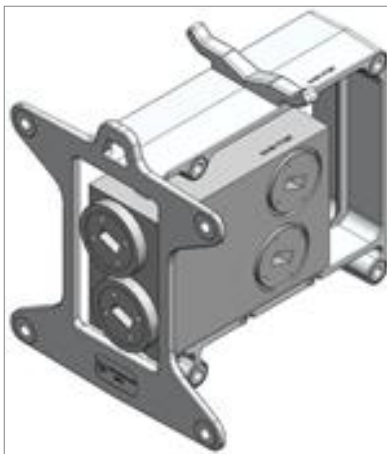

**Figure 9:** *DC OMT*

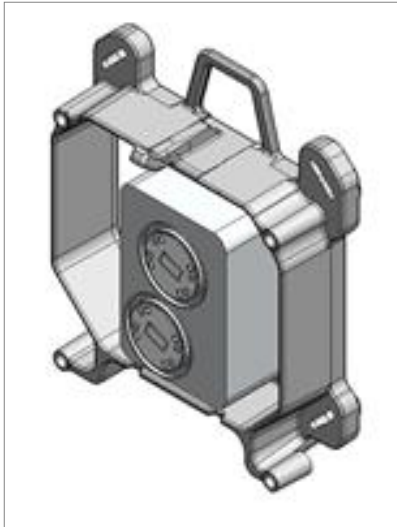

**Figure 10:** *Remote Pole Mount*

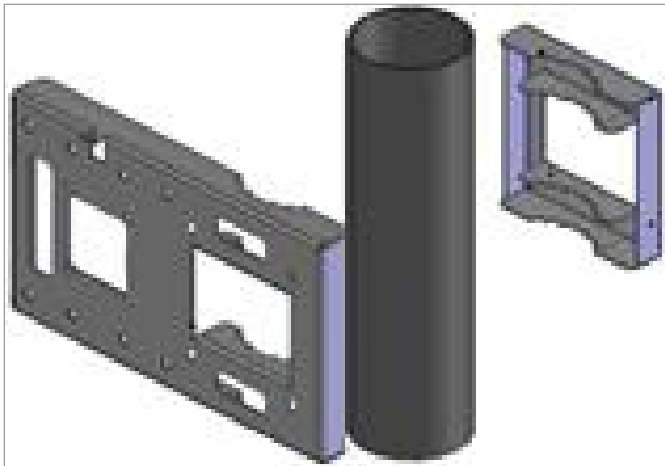

**Figure 11:** *Remote Dual Pole Mount*

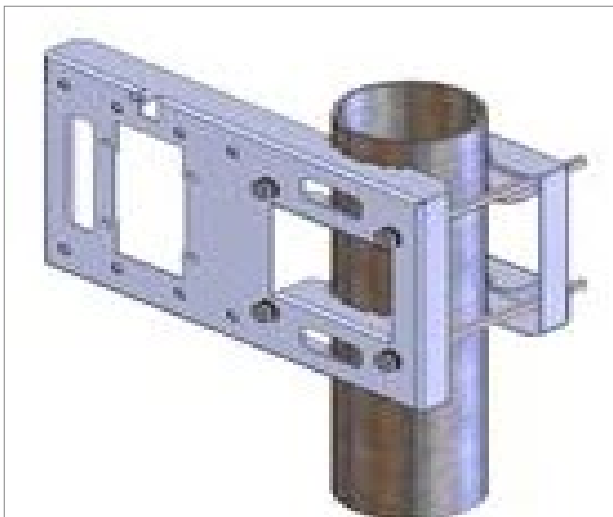

**Figure 12:** *DC Splitte*

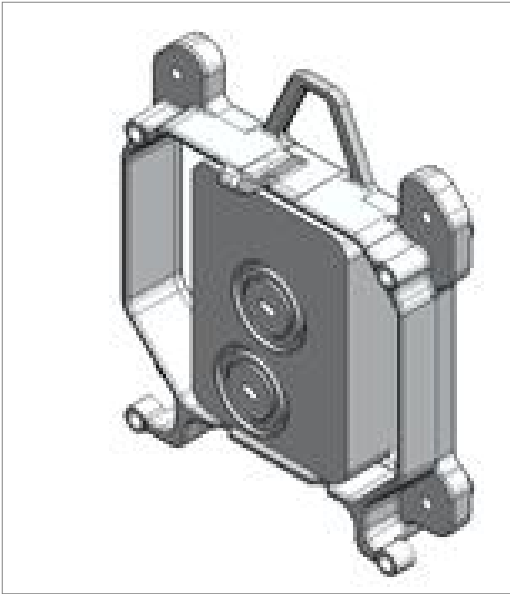

**Figure 13:** *Adaptor for 13 GHz*



**Figure 14:** *PoE Injector*

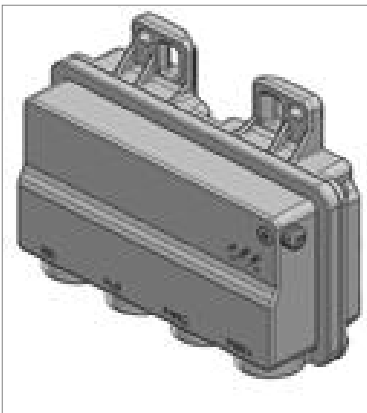

## Adaptors and Installation Kits

**Table 8** Adaptors and Installation Kits, 6 GHz – 18 GHz

Description	6 GHz	7-8 GHz	10-11 GHz	13 GHz	15 GHz	18 GHz
PTP 820C DUAL COUPLER KIT	PTP 820C_DUAL_CPLR_kit_6G	PTP 820C_DUAL_CPLR_kit_7-8G	PTP 820C_DUAL_CPLR_kit_10-11G	PTP 820C_DUAL_CPLR_kit_13G	PTP 820C_DUAL_CPLR_kit_15G	PTP 820C_DUAL_CPLR_kit_18G
PTP 820C DUAL SPLITTER KIT	PTP 820C_DUAL_SPLTR_kit_6G	PTP 820C_DUAL_SPLTR_kit_7-8G	PTP 820C_DUAL_SPLTR_kit_10-11G	PTP 820C_DUAL_SPLTR_kit_13G	PTP 820C_DUAL_SPLTR_kit_15G	PTP 820C_DUAL_SPLTR_kit_18G
PTP 820C SPLITTER KIT	PTP 820C_SPLT_kit_6G	PTP 820C_SPLT_kit_7-8G	PTP 820C_SPLT_kit_10-11G	PTP 820C_SPLT_kit_13G	PTP 820C_SPLT_kit_15G	PTP 820C_SPLT_kit_18G
PTP 820C OMT KIT	PTP 820C_OMT_kit_6G	PTP 820C_OMT_kit_7-8G	PTP 820C_OMT_kit_10-11G	PTP 820C_OMT_kit_13G	PTP 820C_OMT_kit_15G	PTP 820C_OMT_kit_18G
PTP 820C DUAL CORE KIT	PTP 820C_DUAL_CORE_MD_kit_6G	PTP 820C_DUAL_CORE_MD_kit_7_8G	PTP 820C_DUAL_CORE_MD_kit_10-11G	PTP 820C_DUAL_CORE_MD_kit_13G	PTP 820C_DUAL_CORE_MD_kit_15G	PTP 820C_DUAL_CORE_MD_kit_18G
PTP 820C DC ADAPTOR REMOTE MOUNT KIT	PTP 820C_6G_Rmt_Mnt_adpt	PTP 820C_7-8G_Rmt_Mnt_adpt	PTP 820C_10-11G_Rmt_Mnt_adpt	PTP 820C_13G_Rmt_Mnt_adpt		
PTP 820C DC REMOTE MOUNT OMT ADAPTOR KIT	PTP 820C_RM_OMT_6G_adpt	PTP 820C_RM_OMT_7_8G_adpt	PTP 820C_RM_OMT_10-11G_adpt			

**Table 9** Adaptors and Installation Kits, 23 GHz – 38 GHz

Description	23 GHz	26 GHz	28-31 GHz	32 GHz	38 GHz
PTP 820C DUAL COUPLER KIT	PTP 820C_DUAL_CPLR_kit_23G	PTP 820C_DUAL_CPLR_kit_26G	PTP 820C_DUAL_CPLR_kit_28G	PTP 820C_DUAL_CPLR_kit_32G	PTP 820C_DUAL_CPLR_kit_38G
PTP 820C DUAL SPLITTER KIT	PTP 820C_DUAL_SPLTR_kit_23G	PTP 820C_DUAL_SPLTR_kit_26G	PTP 820C_DUAL_SPLTR_kit_28G	PTP 820C_DUAL_SPLTR_kit_32G	PTP 820C_DUAL_SPLTR_kit_38G

Description	23 GHz	26 GHz	28-31 GHz	32 GHz	38 GHz
PTP 820C SPLITTER KIT	PTP 820C_SPLT_kit_23G	PTP 820C_SPLT_kit_26G	PTP 820C_SPLT_kit_28G	PTP 820C_SPLT_kit_32G	PTP 820C_SPLT_kit_38G
PTP 820C OMT KIT	PTP 820C_OMT_kit_23G	PTP 820C_OMT_kit_26G	PTP 820C_OMT_kit_28G	PTP 820C_OMT_kit_32G	PTP 820C_OMT_kit_38G
PTP 820C DUAL CORE KIT	PTP 820C_DUAL_CORE_MD_kit_23G	PTP 820C_DUAL_CORE_MD_kit_26G	PTP 820C_DUAL_CORE_MD_kit_28G	PTP 820C_DUAL_CORE_MD_kit_32G	PTP 820C_DUAL_CORE_MD_kit_38G

**Table 10** Adaptors and Installation Kits, Remote Mount - 6 GHz – 15 GHz

Remote Mount	6 GHz	7-8 GHz	10-11 GHz	13 GHz	15 GHz
RFU-C REMOTE MOUNT KIT	RFU-C-PoleMount				
PTP 820C DC REMOTE MOUNT KIT	PTP 820C-Pole-Mount				
RFU-C ADAPTOR REMOTE MOUNT KIT	RFU-C6-RM_ADAPT	RFU-C7_8-RM_ADAPT	RFU-C10_11-RM_ADAPT	RFU-C13-RM_ADAPT	
RFU-C WG Kit	Fix-WG-4FT-6	Fix-WG-4FT-7_8	Fix-WG-4FT-10_11	Fix-WG-3FT-13	Fix-WG-3FT-15
RFU-C ADAPTOR TO FLEX WG (IMPERIAL) KIT	ADPT_RFU-C6-RM_mill	ADPT_RFU-C7_8-RM_mill	ADPT_RFU-C10_11-RM_mill	ADPT_RFU-C13-RM_mill	ADPT_RFU-C15-RM_mill
PTP 820C DC REMOTE MOUNT OMT ADAPTOR KIT	PTP 820C_RM_OMT_6G_adpt	PTP 820C_RM_OMT_7_8G_adpt	PTP 820C_RM_OMT_10-11G_adpt		

**Table 11** Adaptors and Installation Kits, Remote Mount - 18 GHz – 42 GHz

Remote Mount	18 GHz	23 GHz	26 GHz	28-31 GHz	32 GHz	38 GHz	42 GHz
RFU-C REMOTE MOUNT KIT	RFU-C-PoleMount						
PTP 820C DC REMOTE MOUNT KIT	PTP 820C-Pole-Mount						
RFU-C ADAPTOR REMOTE MOUNT KIT							
RFU-C WG Kit	Flx-WG-3FT-18-26			Flx-WG-3FT-28-38		Flx-WG-3FT-42	
RFU-C ADAPTOR TO FLEX WG (IMPERIAL) KIT	ADPT_RFU-C18_26-RM_mill			ADPT_RFU-C28_38-RM_mill			

**Table 12** 1500P Adaptors - 6GHz – 23 GHz

1500P Adaptors	6 GHz	7-8 GHz	10-11 GHz	13 GHz	15 GHz	18 GHz	23 GHz
RFU-C-PHOSPHORUS DM ADAPTOR KIT			ADPT_RFU-C10_11-DM_1500P	ADPT_RFU-C13-DM_1500P	ADPT_RFU-C15-DM_1500P	ADPT_RFU-C18-DM_1500P	ADPT_RFU-C23-DM_1500P

**Table 13** 1500P Adaptors - 26GHz – 42GHz

1500P Adaptors	26 GHz	28-31 GHz	32 GHz	38 GHz	42 GHz
RFU-C-PHOSPHORUS DM ADAPTOR KIT	ADPT_RFU-C26-DM_1500P	ADPT_RFU-C28-DM_1500P	ADPT_RFU-C32-DM_1500P	ADPT_RFU-C38-DM_1500P	NA

**Table 14** Imperial to mm Transitions – 6GHz – 15GHz

Imperial to mm Transitions	6 GHz	7-8 GHz	10-11 GHz	13 GHz	15 GHz
RFU-C ADAPTOR KIT TO IMPERIAL ANT.	ADPT_RFU-C6-RM_imp	ADPT_RFU-C7_8-RM_imp	ADPT_RFU-C10_11-RM_imp	ADPT_RFU-C13-RM_imp	ADPT_RFU-C15-RM_imp
RFU-C ADAPTOR KIT TO IMP WG	ADPT_RFU-C6-RM_mill	ADPT_RFU-C7_8-RM_mill	ADPT_RFU-C10_11-RM_mill	ADPT_RFU-C13-RM_mill	ADPT_RFU-C15-RM_mill

**Table 15** Imperial to mm Transitions – 18GHz – 42GHz

Imperial to mm Transitions	18 GHz	23 GHz	26 GHz	28-31 GHz	32 GHz	38 GHz	42 GHz
RFU-C ADAPTOR KIT TO IMPERIAL ANT.	ADPT_RFU-C18_26-RM_imp			ADPT_RFU-C28_38-RM_imp			NA
RFU-C ADAPTOR KIT TO IMP WG	ADPT_RFU-C18_26-RM_mill			ADPT_RFU-C28_38-RM_mill			NA

**Table 16** Antenna Circ. Adapters for OMT – 6GHz – 18GHz



**Note:**

This adapter is not required if the antenna is equipped with a circular feeder. Such antenna will have the following marketing model structure:

Am-size(ft)-freq-CIRC-mnf.

Antenna Circ. Adapters for OMT	6GHz	7-8 GHz	10-11 GHz	13 GHz	15 GHz	18 GHz
CommScope	RFU-C6-OMT-INT-A	RFU-C7_8-OMT-INT-A	RFU-C10_11-OMT-INT-A	RFU-C13-OMT-INT-A	RFU-C15-OMT-INT-A	RFU-C18-OMT-INT-A

Antenna Circ. Adapters for OMT	6GHz	7-8 GHz	10-11 GHz	13 GHz	15 GHz	18 GHz
Radio Waves	RFU-C6L-OMT-INT-RW /RFU-C6H-OMT-INT-RW	RFU-C7_8-OMT-INT-RW	RFU-C10_11-OMT-INT-RW	RFU-C13-OMT-INT-RW	RFU-C15-OMT-INT-RW	RFU-C18-OMT-INT-RW
LEAX (Cambium branding)	RFU-C6-OMT-INT-CR1	RFU-C7_8-OMT-INT-CR1	RFU-C10_11-OMT-INT-CR1	RFU-C13-OMT-INT-CR1	RFU-C15-OMT-INT-CR1	RFU-C18-OMT-INT-CR1
Xian Putian (Cambium branding)	RFU-C6-OMT-INT-CR	RFU-C7_8-OMT-INT-CR	RFU-C10_11-OMT-INT-CR	RFU-C13-OMT-INT-CR	RFU-C15-OMT-INT-CR	RFU-C18-OMT-INT-CR
Xian Putian (OEM branding)	RFU-C6-OMT-INT-X	RFU-C7_8-OMT-INT-X	RFU-C10_11-OMT-INT-X	RFU-C13-OMT-INT-X	RFU-C15-OMT-INT-X	RFU-C18-OMT-INT-X

**Table 17** Antenna Circ. Adapters for OMT – 23 GHz – 42 GHz



**Note:**

This adapter is not required if the antenna is equipped with a circular feeder. Such antenna will have the following marketing model structure: Am-size(ft)-freq-CIRC-mnf.

Antenna Circ. Adapters for OMT	23 GHz	26 GHz	28 GHz	32 GHz	38 GHz	42 GHz
CommScope	RFU-C23-OMT-INT-A	RFU-C26-OMT-INT-A	RFU-C28-OMT-INT-A	RFU-C32-OMT-INT-A	RFU-C38-OMT-INT-A	RFU-C42-OMT-INT-A
Radio Waves	RFU-C23-OMT-INT-RW	RFU-C26-OMT-INT-RW	RFU-C28-OMT-INT-RW	NA	RFU-C38-OMT-INT-RW	NA
RFU-C23-OMT-INT-CR1	RFU-C26-OMT-INT-CR1	RFU-C28-OMT-INT-CR1	RFU-C32-OMT-INT-CR1	RFU-C38-OMT-INT-CR1	RFU-C42-OMT-INT-CR1	RFU-C23-OMT-INT-CR1
Xian Putian (Cambium branding)	RFU-C23-OMT-INT-CR	RFU-C26-OMT-INT-CR	RFU-C28-OMT-INT-CR	RFU-C32-OMT-INT-CR	RFU-C38-OMT-INT-CR	NA
Xian Putian (OEM branding)	RFU-C23-OMT-INT-X	RFU-C26-OMT-INT-X	RFU-C28-OMT-INT-X	RFU-C32-OMT-INT-X	RFU-C38-OMT-INT-X	NA

**Table 18** PoE Injector

Marketing Model	Description
PoE_Inj_AO_2DC_24V_48V	POE Injector all outdoor, redundant DC input, -48VDC
PoE_Inj_19inch_Rack_Mnt_kit	PoE Injector 19" Rack Mount Kit
PoE_Inj_ETSI_Rack_Mnt_kit	PoE Injector ETSI Rack Mount Kit

## Antenna Connection

PTP 850CX can be mounted directly for all supported frequencies (13-23 GHz) using the following antenna types (for integrated antennas, specific antennas part numbers are required):

- CommScope: VHLP series
- Xian Putian: WTC/WTG series

For remote mount installations, the following Flexible Waveguide flanges should be used (millimetric). The same antenna type (integrated) as indicated above can be used (recommended).

Other antenna types using the flanges listed in the table below may also be used.

**Table 19** Antenna Flanges

Frequency Band	Range (GHz)	Circ. WG Diameter	Rect. WG Flange Des.	Radio Side (Remote) Flange Des.	Flex WG Side A Flange Des.	Flex WG Side B Flange Des.	Antenna (Remote) Flange Des.
13 GHz	12.7-13.3	15 mm	WR75	UBR120	PBR120	PBR120	UBR120
15 GHz	14.5-15.4	13.5 mm	WR62	UBR140	PBR140	PBR140	UBR140
18 GHz	17.7-19.7	10.5 mm	WR42	UBR220	PBR220	PBR220	UBR220
23 GHz	21.2-23.6	9 mm					

If a different antenna type (CPR flange) is used, a flange adaptor is required. Please contact your Cambium representative for details.



**Note:**

Appropriate lubricant or grease can be applied to the screws that connect the PTP 850CX to the antenna interface.

# Power Specifications

## Electrical Requirements

- -48V DC Nominal

## Important Notes!

- The unit must only be installed by service personnel.
- The unit must have a permanent connection to protective grounding.
- The RSL interface connector is intended for technician use only.
- Disconnect device (circuit breaker) in the building installation:
  - Shall be readily accessible and incorporated external to the equipment.
  - For overcurrent protection, a 6A fast acting breaker is recommended.

# Environmental Specifications

Operating: ETSI EN 300 019-1-4 Class 4.1

Temperature range: -33°C (-27°F) to +55°C (131°F)

Humidity: 5%RH to 100%RH IEC529 IP66

Storage: ETSI EN 300 019-1-1 Class 1.2

Transportation: ETSI EN 300 019-1-2 Class 2

# Cable Installation and Grounding

## Minimum and Maximum Cable Diameter

To fit the gland, the outer cable diameter should be between 6-10 mm. This applies to all glands on both the PTP 850CX unit and the PoE Injector.

## Grounding the Cables

Cables must be grounded as follows:

- For fiber cables (see [Connecting an Optical Fiber Cable and SFP](#)), no grounding is required.
- For DC power cables (see [Connecting a DC Power Cable](#)), no grounding is required.
- For Ethernet cables, the shielded Ethernet cable (SF/UTP construction) must be grounded to the antenna tower at the top (next to the PTP 850CX unit), the entry to the indoor cabinet, and every 50m, using the kit UNIV\_GRD\_KIT\_1/2.

**Figure 15:** Cable Grounding Kit

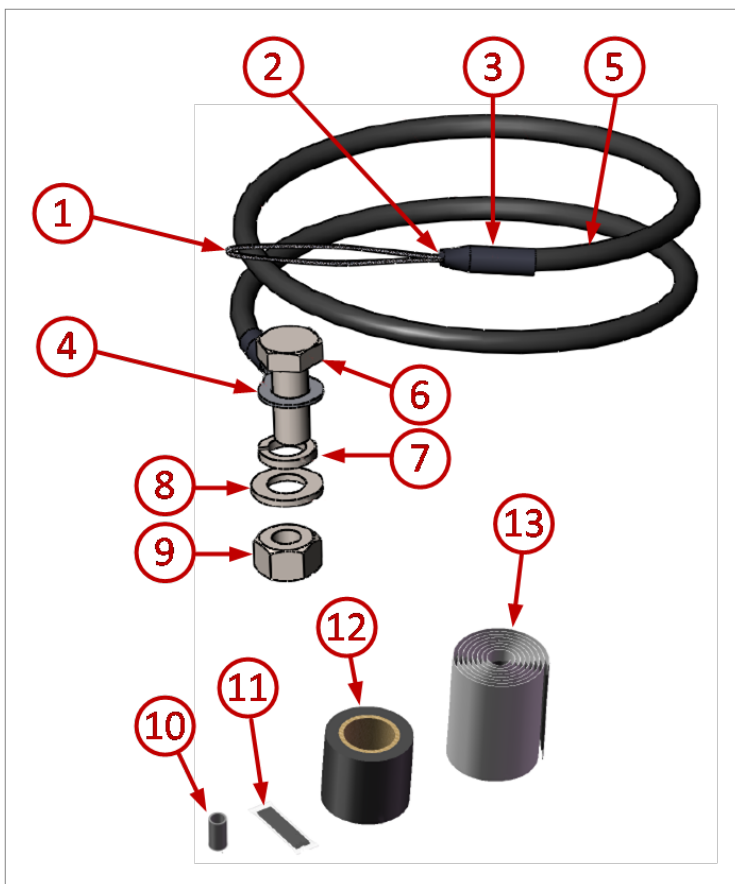
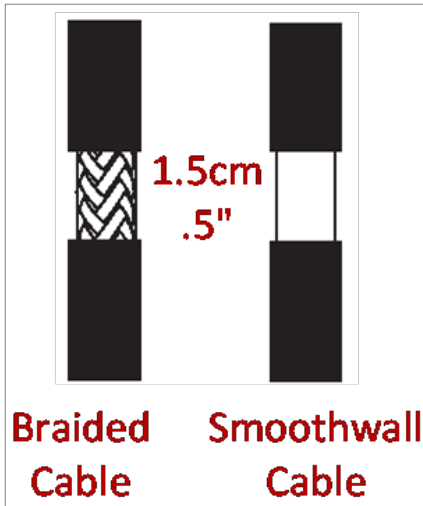

**Table 20** Cable Grounding Kit

Marketing P/N	Description
UNIV_GRD_KIT_1/2	Universal Grounding Kit up to 1/2" cable

To connect the grounding kit:

1. Strip the cable jacket about 1.5 cm (.5").



2. Loop the grounding wire's braid belt (1) around the stripped portion of the cable, insert the rest of the grounding wire (5) through the braid belt, and tighten to form a knot, as shown in the figure below.

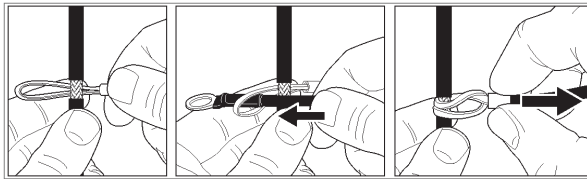

3. Grasp the terminal of the braid belt (2) and slide it flush with the knot around the cable, as shown in the figure below.

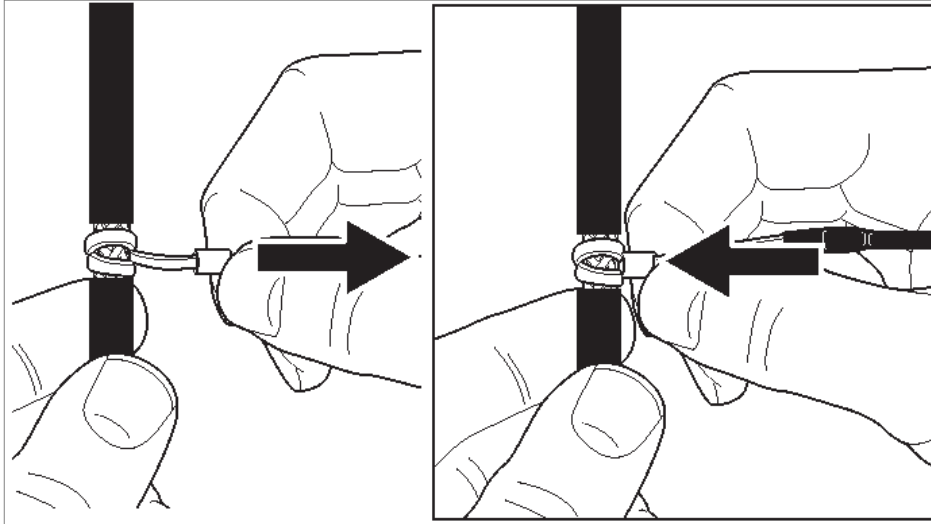

4. Crimp the knotted braid belt (1) and the bare terminal (10) together, as shown in the figures below.

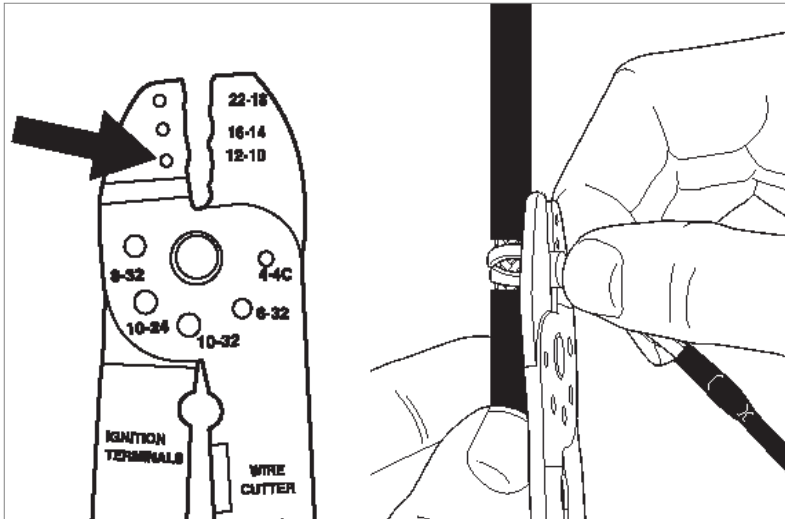

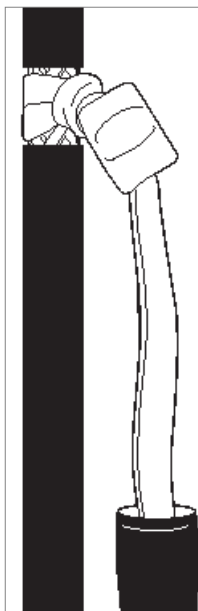
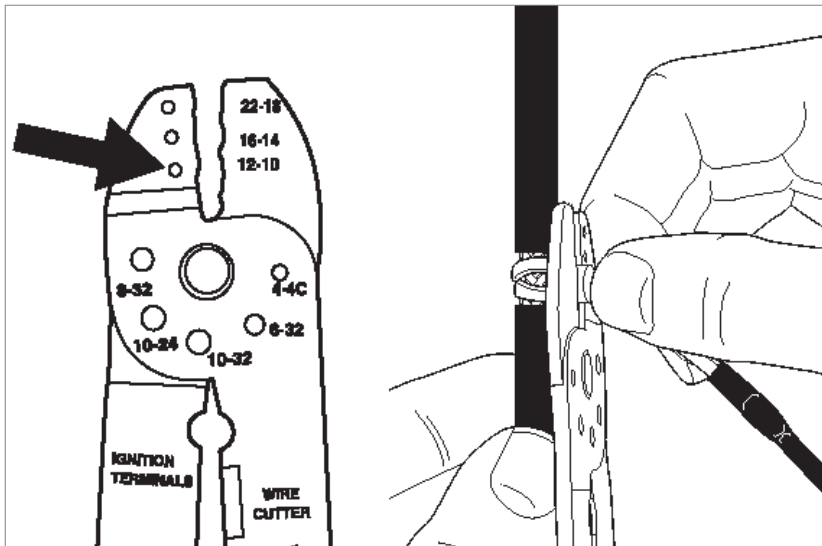

5. Wrap the butyl rubber sealing clay (13) around the cable and the grounding wire, as shown in the figures below.

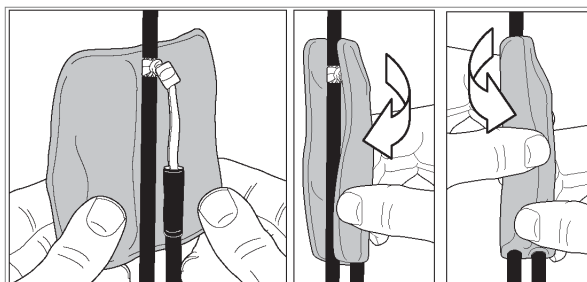

6. Cut four strips of the tape (12), approximately 20 cm (8") each, and wrap these strips of tape around the butyl rubber sealing clay (13), as shown in the figures below.

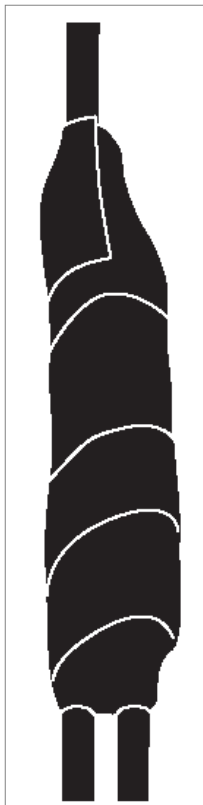
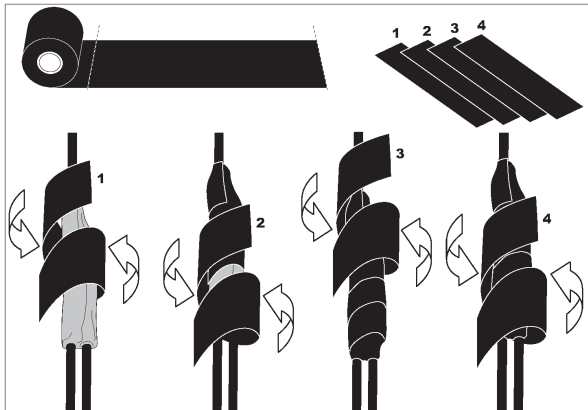

7. Pass the hex bolt (6) through the copper lug at the end of the grounding wire (4), and secure it to the grounding bar using the flat washer (7), the spring washer (8), and the nut (9). Use conductive grease (11) on the bolt and nut to ensure proper contact.

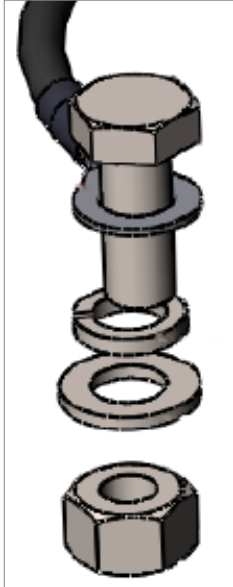

## Grounding the PTP 850CX Unit



**Note:**

The PTP 850CX is internally grounded on the positive (+) side.

The grounding of the PTP 850CX and the PoE must be connected with a grounding cable to the closest main grounding point. The grounding cable must be at least 6 AWG or wider. The recommended length of the grounding cable is up to 2 meters, but in any case not more than 6 meters. The recommended resistance between the tower's main grounding point and the PTP 850CX chassis is 2.5 m $\Omega$  or less, but in any case not more than 10 m $\Omega$ .

If a PoE is used, the recommended resistance between the tower's main grounding point and the PoE chassis is:

- If the PoE is installed outdoors: 2.5 m $\Omega$  or less, but in any case not more than 10 m $\Omega$ .
- If the PoE is installed indoors: 5 m $\Omega$  or less.

### Required Tools

- Metric offset wrench key wrench #3
- Metric wrench 10mm

## Procedure



1. On the front of each PTP 850CX unit, loosen the nut, plain washer, and serrated washer from the GND stud, using the metric offset hexagon key and the wrench.
2. Place the cable lug (supplied with the PTP 850CX grounding kit) in place on the screw.
3. Secure the cable lug.
4. The second side of the GND cable should be connected to the main ground bar or terminal ground bar of the site.



**Note:**

The unit's earthing screw terminal shall be permanently connected to protective earth in a building installation in accordance with applicable national code and regulations by a service person.

A 2-pole circuit breaker, a branch circuit protector, suitably certified in accordance with applicable national code and regulations, shall be installed for full power disconnection in a building installation.

Any outdoor antenna cable shield shall be permanently connected to protective earth in a building installation.

## Power Source

The power cable must be plugged into the unit before turning on the external power.

When selecting a power source, consider that the operating voltage levels of the PTP 850CX can be from -40.5 VDC to -60 VDC.



**Note:**

Availability of a UPS (Uninterrupted Power Source), battery backup, and emergency power generator.

The power supply must be grounded as follows:

- The AC side must be grounded
- The DC side must be positive grounded according to the standard.



**Note:**

For the warranty to be honored, you must install the PTP 850CX in accordance with the instructions above.

## Surge Protection

PTP 850CX includes built-in surge protection for its Ethernet and power interfaces. PTP 850CX's surge protection implementation complies with surge immunity standard IEC 61000-4-5, level 4, provided the Ethernet cables were prepared according to the instructions in [Connecting the Ethernet Cable](#).

However, when using an electrical SFP connection with CAT5 or CAT6 Ethernet cable, internal surge protection is not present and an external surge protector is recommended. It is recommended to use the surge protector described in [Table 21](#).



**Note:**

Electrical SFPs are not supported in the initial release. For details, refer to the Release Notes for the System Release version you are using.

**Note:** To provide maximum protection, make sure to prepare the Ethernet cables according to the instructions in [Connecting the Ethernet Cable](#) and to ground the cables in accordance with the instructions in [Grounding the Cables](#).

In areas in which severe lightning conditions are likely to occur, it is strongly recommended to add additional protection by placing surge protectors on all electrical Ethernet cables, near the connection points with the PTP 850CX unit.

The following surge protector is available from Cambium.

**Table 21** *Surge Protector*

Marketing Model	Item Description
Outdoor/LPU/GBE	Outdoor Lightning Protection Unit for 10/100/1000Base-T PoE



**Note:**

In order for the surge protection devices to work properly , the PTP 850CX unit must be properly grounded according to Section [Grounding the PTP 850CX Unit](#).

# Available Cable Options

## Fiber Optic Cables - Single Mode

**Table 22** *Fiber Optic Cables - Single Mode*

Marketing Model	Description
N000082L205A	CABLE,FO,MPO(F)/MPO(F),4P,TYPE B,30M,MM,OM3,M28 GLAND,ARM
N000082L206A	CABLE,FO,MPO(F)/MPO(F),4P,TYPE B,50M,MM,OM3,M28 GLAND,ARM
N000082L207A	CABLE,FO,MPO(F)/MPO(F),4P,TYPE B,80M,MM,OM3,M28 GLAND,ARM

## Fiber Optic Cables - Multi Mode

**Table 23** *Fiber Optic Cables - Multi Mode*

Marketing Model	Description
PTP 820_FO_MM_LC2LC_ARM_7m	CABLE,FO,DUAL LC/LC,7M,MM,55mm OPEN END,M28 GLAND,ARMORED,OU
PTP 820_FO_MM_LC2LC_ARM_15m	CABLE,FO,DUAL LC/LC,15M,MM,55mm OPEN END,M28 GLAND,ARMORED,O
N000082L193A	CABLE,FO,DUAL LC/LC,20M,MM,55mm OPEN END,M28 GLAND,ARMORED
N000082L194A	CABLE,FO,DUAL LC/LC,30M,MM,55mm OPEN END,M28 GLAND,ARMORED,O
N000082L195A	CABLE,FO,DUAL LC/LC,50M,MM,55mm OPEN END,M28 GLAND,ARMORED,O
N000082L196A	CABLE,FO,DUAL LC/LC,80M,MM,55mm OPEN END,M28 GLAND,ARMORED,O
N000082L197A	CABLE,FO,DUAL LC/LC,100M,MM,55mm OPEN END,M28 GLAND,ARMORED
N000082L198A	CABLE,FO,DUAL LC/LC,150M,MM,55mm OPEN END,M28 GLAND,ARMORED
N000082L199A	CABLE,FO,DUAL LC/LC,200M,MM,55mm OPEN END,M28 GLAND,ARMORED

## DC Cable and Connector

**Table 24** DC Cable and Connector

Marketing Model	Description
Outdoor_DC_cbl_2x18AWG_drum	CABLE,305M,OUTDOOR_DC_CBL_2X18AWG_DRUM
PTP 820C_DC_Conn	PTP 820C_DC_Conn

## Cables for Layer 1 Link Aggregation Configurations

**Table 25** Cables for Layer 1 Link Aggregation Configurations

Marketing Model	Description
Data_SHARING_CBL_1m	Fiber Protocols cable, 1m
Data_SHARING_SM_CBL_1m	Fiber Data sharing cable, SM, 1m
Data_SHARING_CBL_5m	Fiber Protocols cable, 5m
Data_SHARING_SM_CBL_7m	Fiber Data sharing cable, 7m
Data_SHARING_CBL_10m	Fiber Protocols cable, 10m
Data_SHARING_SM_CBL_10m	Fiber Data sharing cable, 10m
Data_SHARING_CBL_20m	Fiber Protocols cable, 20m
Data_SHARING_CBL_30m	Fiber Protocols cable, 30m

## Ethernet Cable and Specifications

**Table 26** Ethernet Cable and Specifications

Marketing Model	Description
CAT5E_SFUTP_Outdoor_50m	CABLE,RJ45 TO RJ45 STR 50M,CAT-5E,ETHER,UV RES
CAT5E_SFUTP_Outdoor_75m	CABLE,RJ45 TO RJ45 STR 75M,CAT-5E,ETHER,UV RES
CAT5E_SFUTP_Outdoor_305m_drum	CABLE,MATERIAL,CAT-5E,SFUTP,4X2X24AWG,UV RESISTANCE,305M
CAT5E_Arm_50m	CABLE,RJ45 TO RJ45 STR,50M,CAT-5E,M28 GLAN,ARM,UV RESISTANCE
CAT5E_Arm_70m	CAT5E_Arm_75mCABLE,RJ45 TO RJ45 STR,70M,CAT-5E,M28 GLAN,ARM,UV RESISTANCE

Marketing Model	Description
N000082L016A	CABLE,MATERIAL,CAT-5E,SFUTP,4X2X24AWG,UV RESISTANCE,100M
CAT5E_Arm_305m_drum	CABLE,MATERIAL,CAT-5E,FTP,4X2X24AWG,ARMORED,UV RESIST,305M
N000082L172A	CABLE,MATERIAL,CAT-6A,SFTP,4X2X22AWG,UV RESISTANCE,305M



**Note:**

It is strongly recommended to source the CAT-6A cable from Cambium.

This cable has the following specifications:

- Suitable for:
  - Fast Ethernet
  - Gigabit Ethernet
  - PoE

Cable Design – The numbers in the figure below refer to the items listed beneath the figure.

**Figure 16:** Cable Design

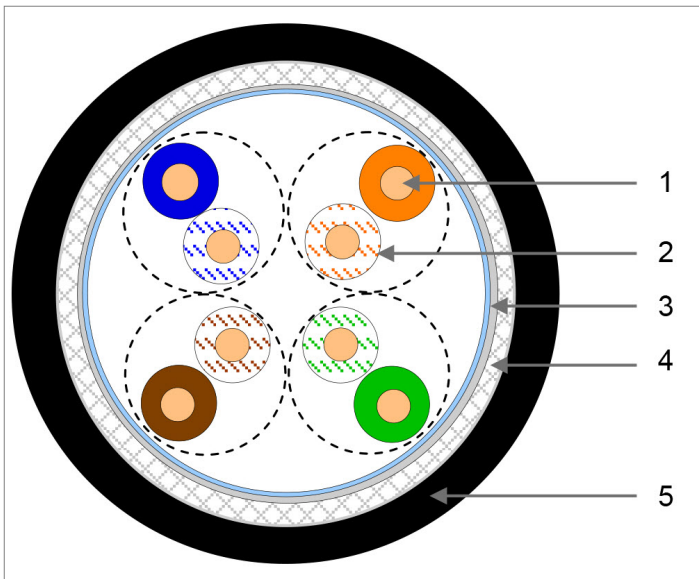

- [1] Conductor
- [2] Insulation
- [3] Screen: Alu/Pet foil. Alu outside
- [4] Tinned copper braid
- [5] Jacket

**Table 27** Ethernet Cable Color Code









Pair	Wire A	Wire B
1	WHITE-blue	BLUE
2	WHITE-orange	ORANGE
3	WHITE-green	GREEN
4	WHITE-brown	BROWN

## Outdoor Ethernet Cable Specifications

**Table 28** Outdoor Ethernet Cable Specifications – Electrical Requirements

Cable type	CAT-5e SFUTP, 4 pairs, according to ANSI/TIA/EIA-568-B-2
Wire gage	24 AWG
Stranding	Solid
Voltage rating	70V
Shielding	Tinned copper Braid (Coverage: >=80%) + Aluminum Foil

**Table 29** Outdoor Ethernet Cable – RJ-45 Connector Pinout

Pin #	Wire Color Legend	Signal
1	 White/Orange	TX+
2	 Orange	TX-
3	 White/Green	RX+
4	 Blue	TRD2+
5	 White/Blue	TRD2
6	 Green	RX-
7	 White/Brown	TRS3+
8	 Brown	TRD3-

Pin #	Wire Color Legend	Signal
	Brown	

**Table 30** Outdoor Ethernet Cable Specifications – Mechanical/ Environmental Requirements

Jacket	UV resistant
Outer diameter	6-10 mm
Operating and Storage temperature range	-40°C - 85°C
Flammability rating	According to UL-1581 VW1, IEC 60332-1
RoHS	According to Directive/2002/95/EC



**Note:**

It is strongly recommended to source CAT-6A cable from Cambium.

## Outdoor DC Cable Specifications

**Table 31** Outdoor DC Cable Specifications – Electrical Requirements

Cable type	2 tinned copper wires
Wire gage	See <a href="#">Power Specifications</a>
Stranding	stranded
Voltage rating	600V
Spark test	4KV
Dielectric strength	2KV AC min

**Table 32** Outdoor DC Cable Specifications – Mechanical/ Environmental Requirements

Jacket	UV resistant
Outer diameter	7-10 mm
Operating and Storage temperature range	-40°C - 85°C
Flammability rating	According to UL-1581 VW1, IEC 60332-1
RoHS	According to Directive/2002/95/EC

## Securing the Cables

All cables should be secured at every meter on-site using either a T-Rups kit, P/N Outdoor Ties (SI-0027-0) or cable clamps. When using the T-Rups kit, take special care to apply the proper amount of force in order to avoid damage to the cable. This is especially important for optical (SFP) cables.

The following cable clamps are available:

**Table 33** Cable Clamps

Part Number	Marketing Model	Item Description
SI-1231-0	Fiber_clamp_6cbl_4.0-7.0mm	DUAL FEADER CLAMP FOR 4.0-7.0mm CABLE 6 WAY.

## Special Instructions for use of Glands



**Note:**

Each PTP 850CX unit is supplied with two glands. If additional glands are required, they must be ordered separately, in kits of five glands each.

**Table 34** Glands Kit

Marketing Model	Marketing Description
PTP 820_Glands_kit	PTP 820_Glands_x5_kit

In addition, gland caps can be ordered to protect the cable and connector from damage when elevating the cable and gland to the radio unit. See Step 5 in Section [General Installation Procedure](#). Gland caps are ordered separately, in kits of 10 caps each.

**Table 35** Gland Caps

Marketing Model	Marketing Description
N800082L009A	KIT 10pcs of M28 Gland Cap With Hook (AA-0678-0)

In order to remove the plastic plugs for the unit, you can use the flange of supplied glands to disconnect them. See figures below.

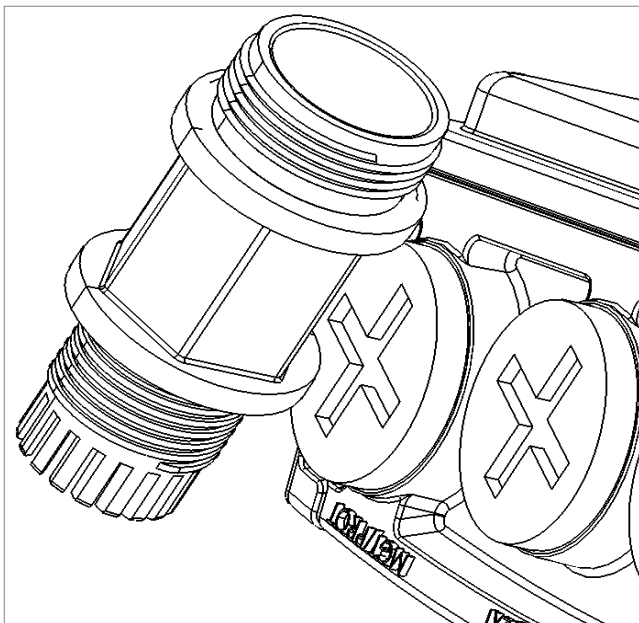

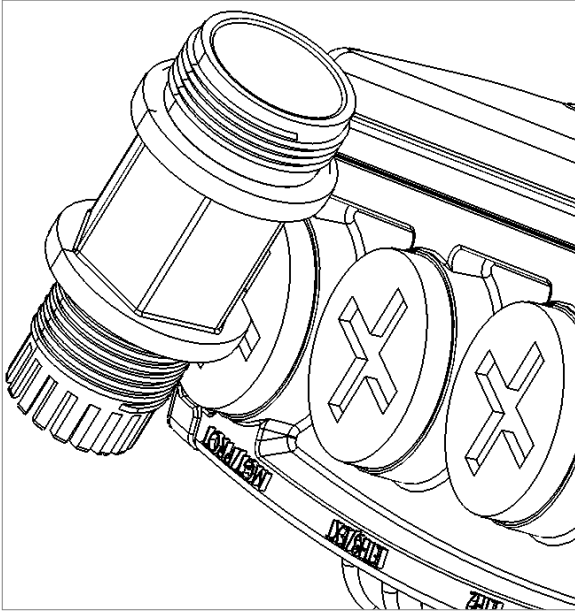

## General Installation Procedure

This procedure applies to all cable types, and explains how to install the cables using long glands. The gland is supplied assembled.

1. Before inserting a cable, you must disassemble the gland cap and gland rubber from the gland body.

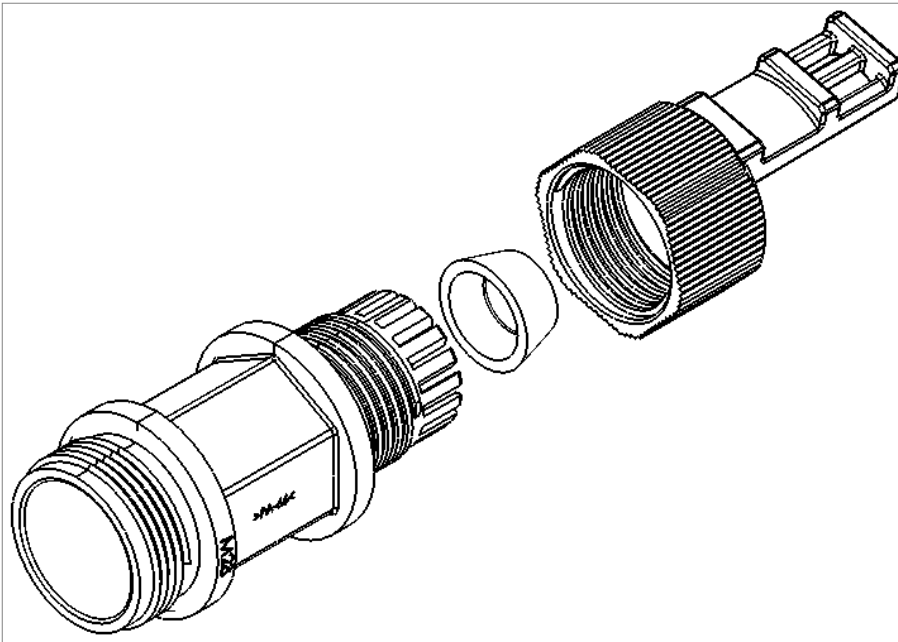

2. Slide the gland cap into the cable.

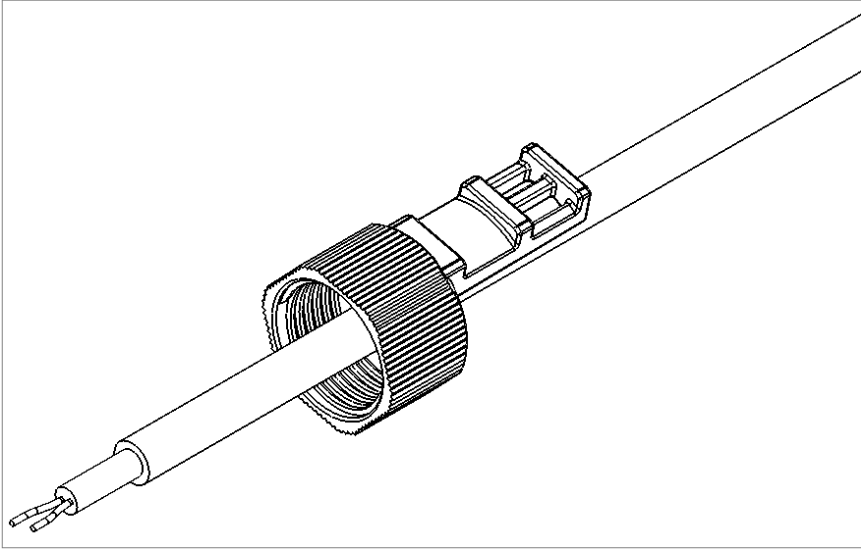

3. Slide the gland rubber into the cable.

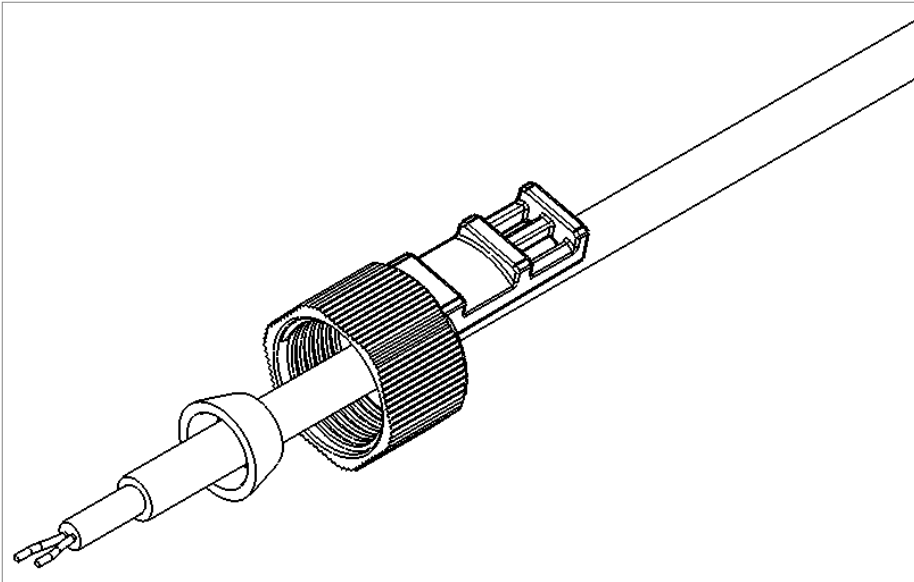

4. Slide the cable into the body of the gland. If you are using a gland cap (see [Step 5](#)), make sure to leave enough space for the gland cap to fit into the gland without disturbing the cable.

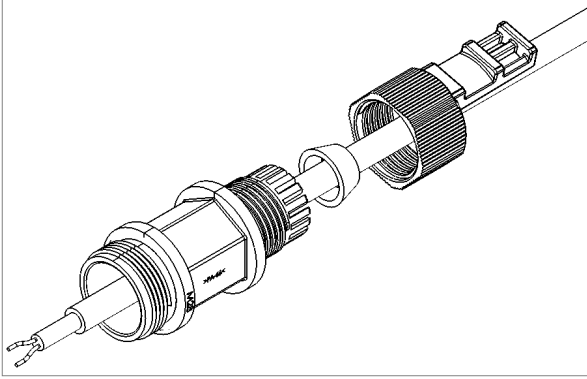

5. Optionally, after securing the cable into the body of the gland, you can close the other side of the gland with an M28 gland cap. The gland cap protects the cable and connector from damage when elevating the cable and gland to the radio unit.

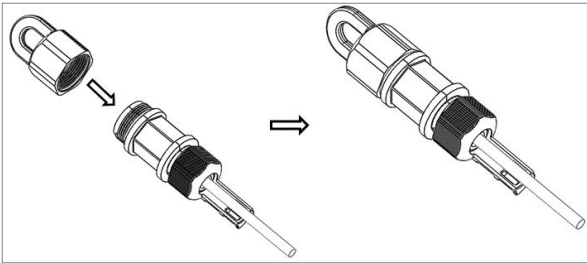

6. The M28 gland cap has a hook on top. After attaching the gland cap to the gland, you can connect a rope to the hook and use this to lift the gland and cable up to the radio unit. Before screwing the gland into the radio unit, you must remove the gland cap.

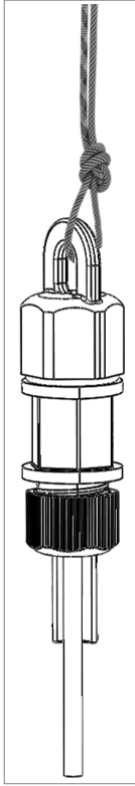

7. If you used an M28 gland cap to close the gland when raising the gland and cable to the radio unit, remove the gland cap from the gland at this point by unscrewing the cap.
8. Connect the cable to the port.
9. Screw the gland into the radio unit until there is full contact between the gland and the radio unit.

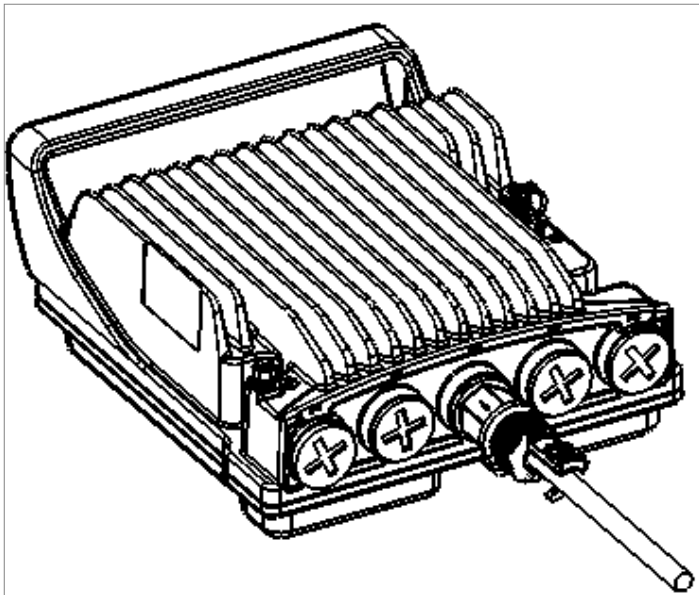



**Note:**  
Before tightening the gland, make sure the gland is aligned with the tapped hole in the unit. Tightening the gland at an angle can ruin the thread on the gland and prevent proper sealing of the interface.

10. Insert the main part of the gland into the thread in the radio body and tighten until there is full contact and the gasket is fully contained between the gland and the radio and cannot be seen. Tighten the gland gently and make sure there is no resistance. If there is resistance, stop immediately, and thread out the gland. Verify that the gland thread is not damaged and tighten the gland again.



**Note:**  
Pay attention that the gland rubber is properly located and not damaged during the tightening of the gland cap.  
If the gland thread is damaged do not use it!

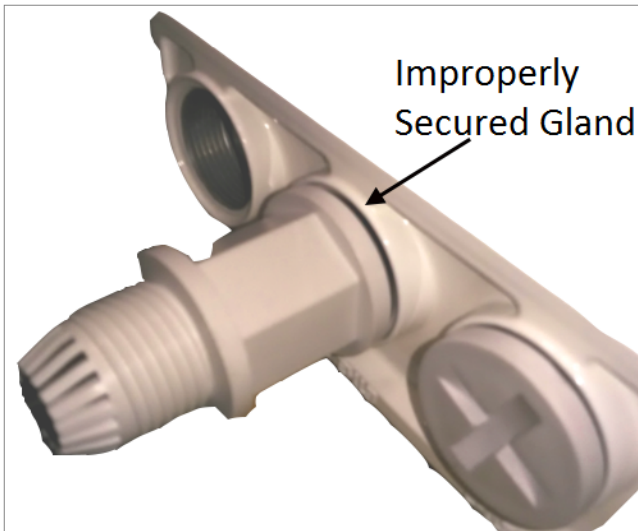

11. Tighten the rear portion of the gland onto the main part of the gland and make sure that the main part of the gland does not have an additional swivel after the rear portion is secured.



**Note:**

If the main portion of the gland is rotated while the rear portion is seizing the cable, this may ruin the cable connector.

**Figure 17:** Tightening the Front Portion of the Gland and Tightening the Rear Portion of the Gland

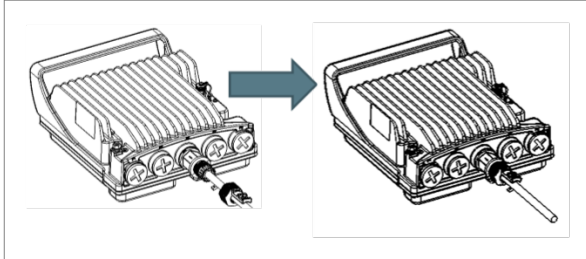

12. Secure the cable to the lip of the gland using a tie wrap.

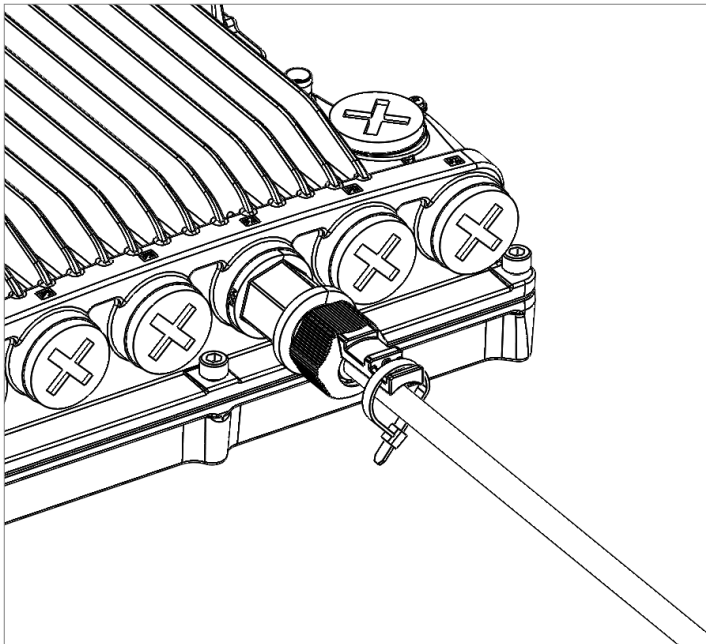

## Connecting an Optical Fiber Cable and SFP

To connect an optical fiber cable and the SFP transceiver:

1. Use a pre-assembled cable.

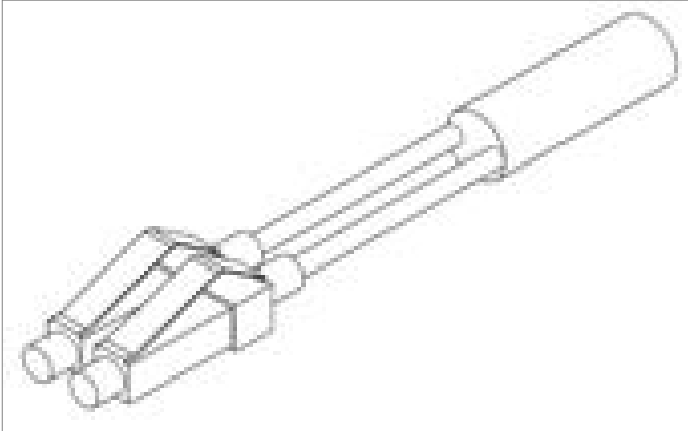

2. Split the connector into two separate LC connectors (one for each fiber).

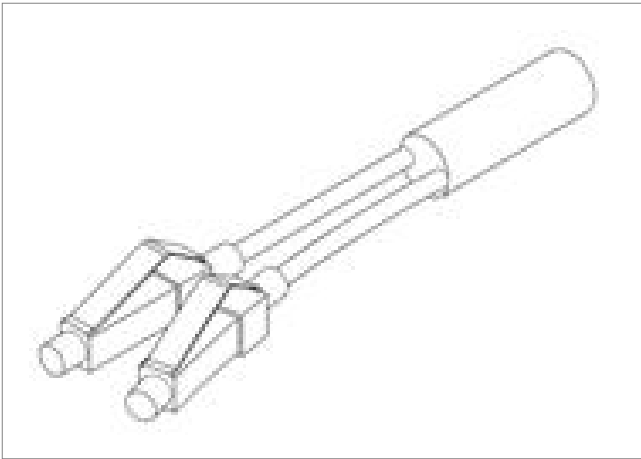

3. Remove the gland cap and rubber from the gland body.

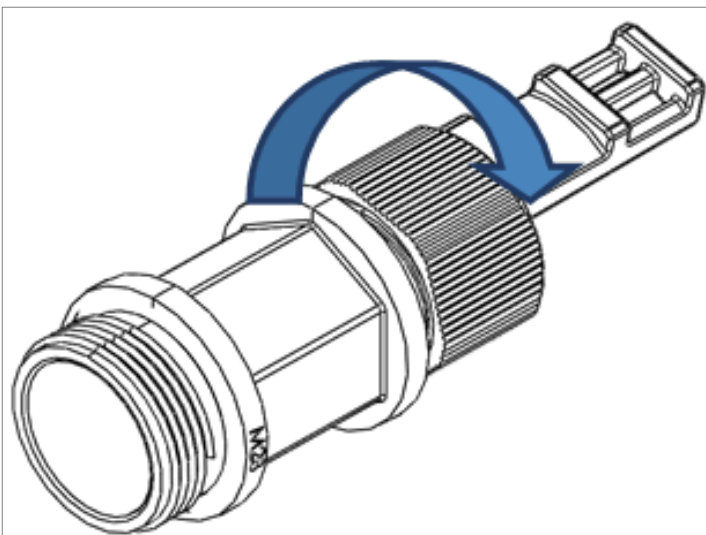

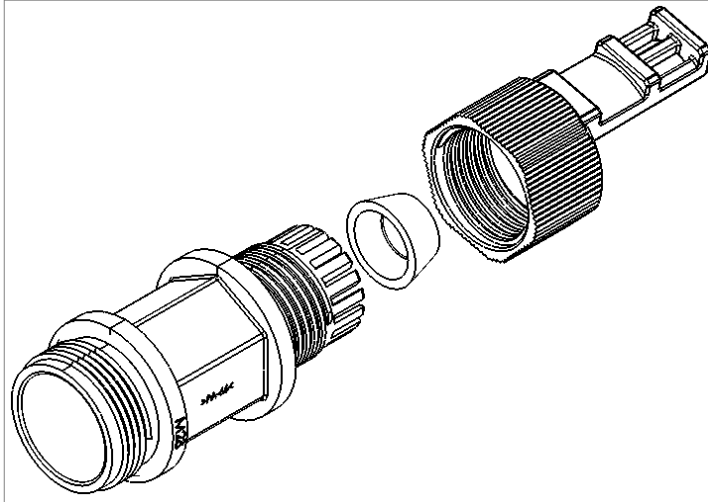

4. Slide the gland cap into the cable.
5. Slide the rubber into the cable.
6. Insert the fibers with the connectors one by one into the cable gland.

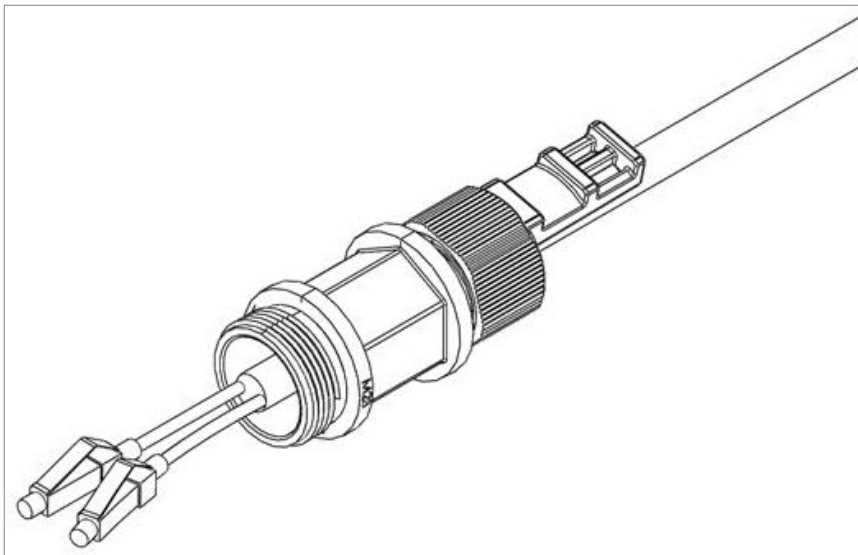

7. Secure the cable to the lip of the gland using a tie wrap.



**Note:**

If you are raising the cable to a radio unit on a tower, this step is crucial to prevent the cable from slipping from the gland, which could damage the connector.

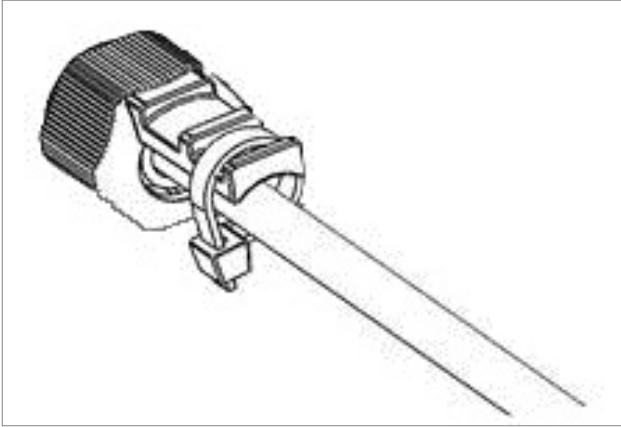

8. Connect the fibers to the SFP transceiver. Listen for the “click” to ensure that they are fully inserted.

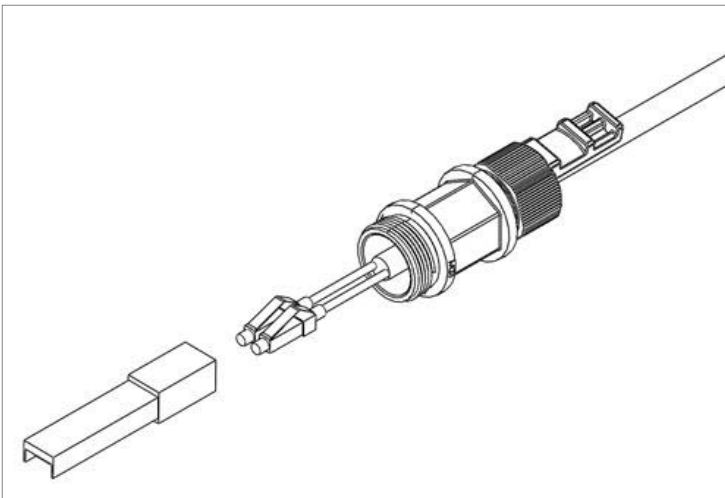

9. Remove the tie wrap securing the cable to the gland.



**Note:**

A new tie wrap must be used to secure the cable to the gland at the end of the procedure, as described in [Step 13](#).

10. Connect the connector into the PTP 850CX connector.

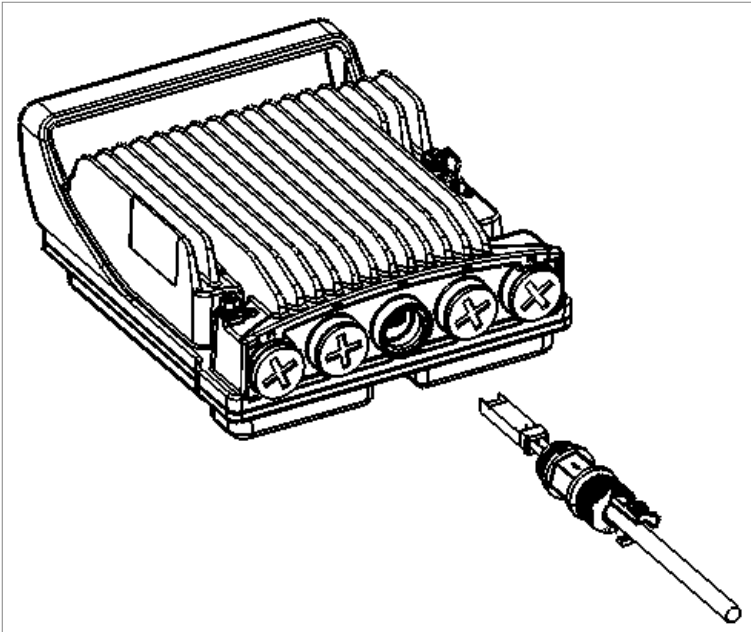

11. Tighten the gland to the radio unit until there is full contact between the gland and the radio unit.
12. Tighten the gland cap.



**Note:**

Before tightening the gland, make sure the gland is aligned with the tapped hole in the unit.

Tightening the gland at an angle can ruin the thread on the gland and prevent proper sealing of the interface. Tighten the gland gently and make sure there is no resistance. If there is resistance, stop immediately, thread out the gland, and verify that the gland threads are not damaged. Then, tighten the gland again.

If the gland thread is damaged do not use it.

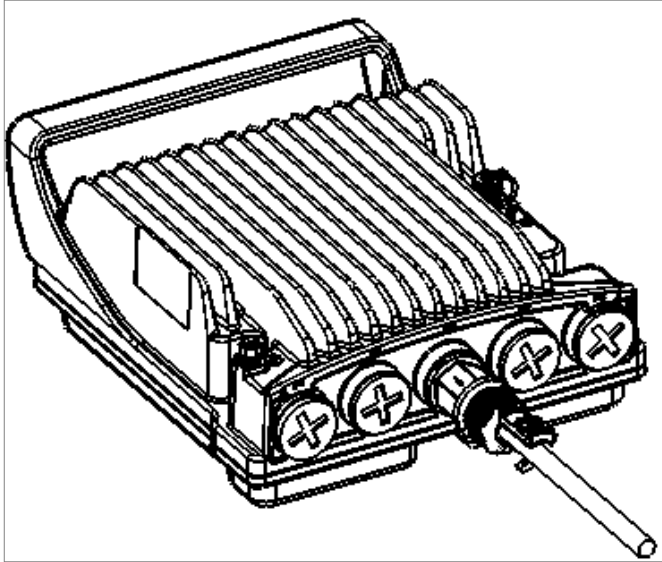

13. Secure the cable to the gland using a tie wrap.

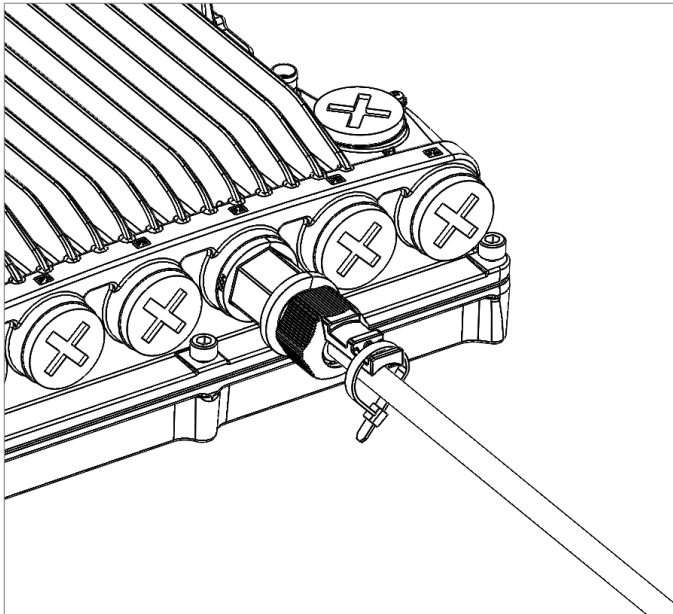

## Connecting a DC Power Cable



**Note:**

The DC power cable and connector must be ordered separately. See [DC Cable and Connector](#).

To connect a DC power cable:

1. Strip off 45 mm from the cable jacket.
2. Expose 10 mm at the edge of each of the two wires.

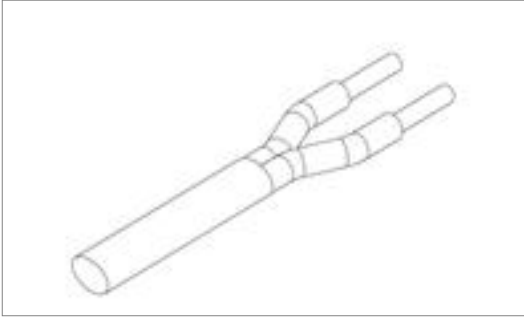

3. Insert the power cable into the gland.

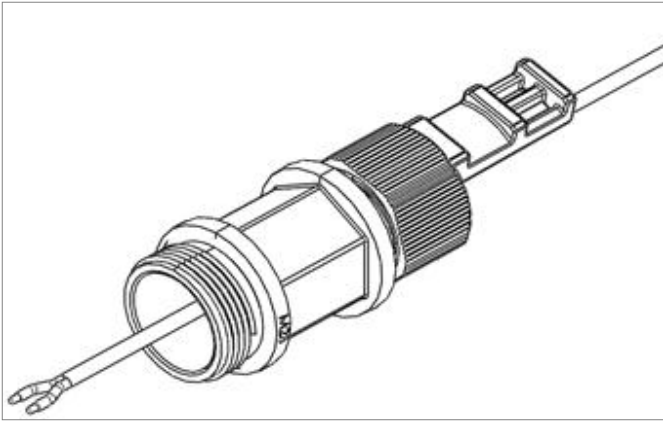

4. Insert the power cable wires into the power connector.
5. Insert the power cable wires into the power connector. Match “+” to the 0V wire and “-” to the -48V wire.

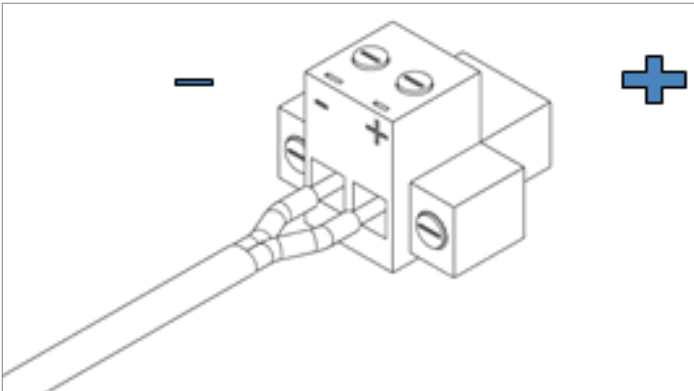

6. Tighten the two top screws.

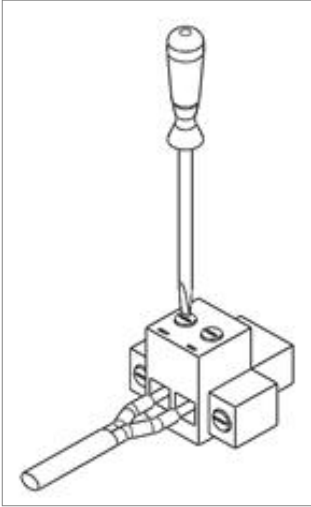

7. Plug the power cable with connector into the PTP 850CX power connector.

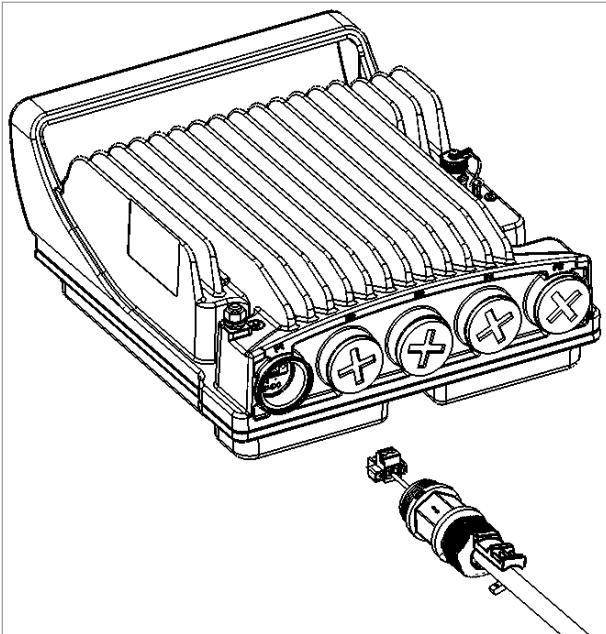

8. Tighten the two front screws.

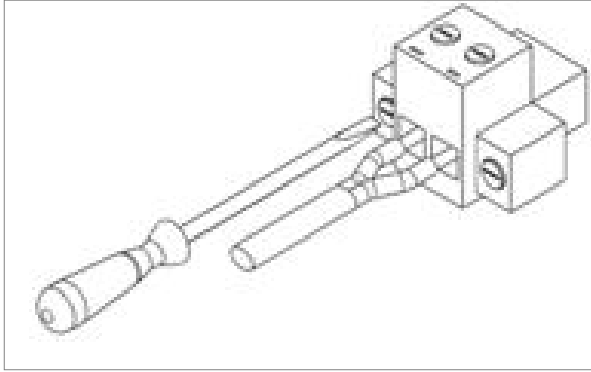

9. Screw the gland into the radio unit



**Note:**

Before tightening the gland, make sure the gland is even with the cover. Tighten the gland gently and make sure there is no resistance. If there is resistance, stop immediately and verify that the gland is not being inserted at an angle. Tightening the gland at an angle can ruin the thread on the gland and prevent proper sealing of the interface.

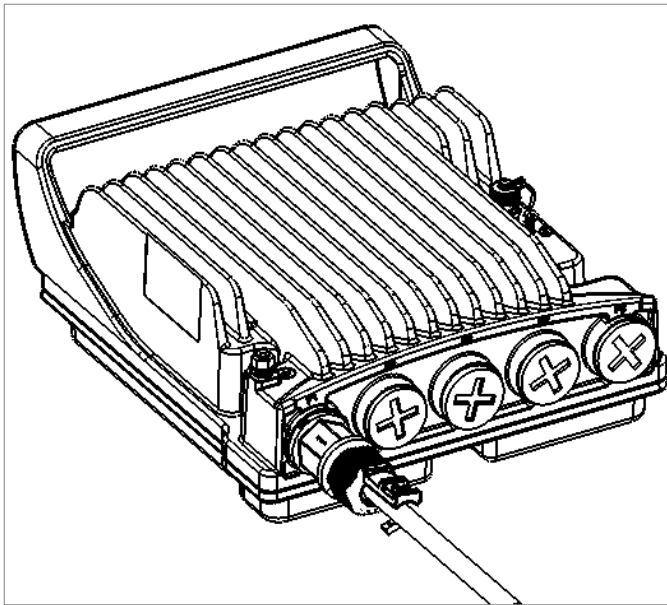

10. Tighten the gland cap.
11. Secure the cable to the gland with a tie wrap.

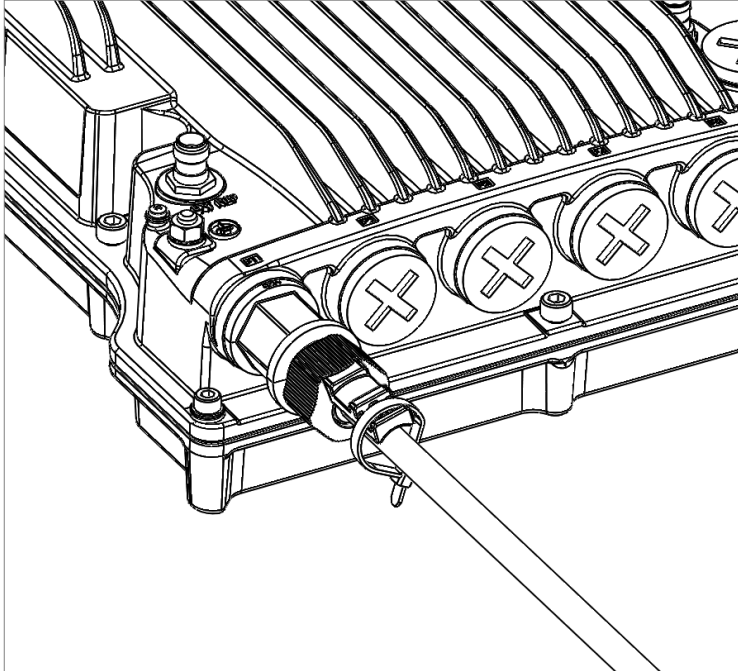

## Connecting the Ethernet Cable

If you need to assemble the Ethernet cable, follow the instructions in section [Preparing the Ethernet Cable and Plug-in Field](#), then proceed to section [Connection of Ethernet Cable to PTP 850CX](#).

If you are using a pre-assembled Ethernet cable, follow the instructions in section [Preparing the Ethernet Cable Already Assembled](#), then proceed to section [Connection of Ethernet Cable to PTP 850CX](#).



**Note:**

To ensure proper grounding and connectivity, it is recommended to use pre-assembled Ethernet cables.

## Preparing the Ethernet Cable and Plug-in Field



**Note:**

To ensure proper grounding, the RJ-45 plug must be shielded, with a crimping tail.

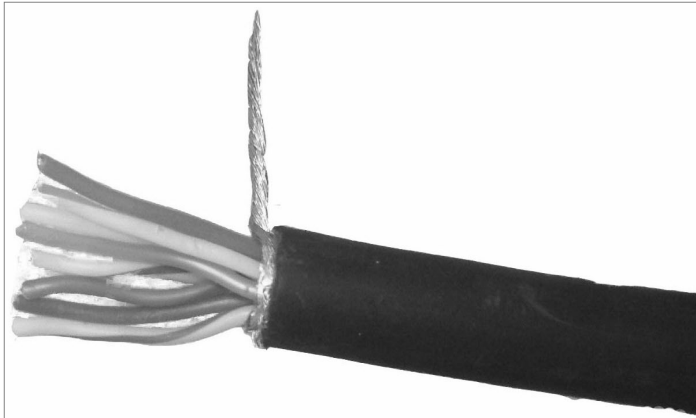

**Table 36** Materials for Preparing Ethernet Data Cables

Marketing P/N	Description
N000082L016A	CABLE,MATERIAL,CAT-5E,SFUTP,4X2X24AWG,UV RESISTANCE,100M
N000082L059A	KIT 5pcs of M28 GLAND (AA-0597-0)
N000082L173A	Universal Grounding Kit up to 1/2" cable
N000082L073A	RJ45 CAT5E CONNECTORS AND BOOTS KIT (package of 10 connectors)
N000082L174A	CONN,FOR CABLE,RJ45,T568A,FOR CAT6a 22-24AWG

To prepare the Ethernet cable and plug-in field:

1. Prepare the gland and insert the cable, as described in [General Installation Procedure](#).
2. Strip off approximately 45 mm of the outer insulation jacket from the CAT5E cable.
3. Do not strip off the end of the cable shield, but rather, twist the shield to form a braid.



4. Roll back the foil shield insulation and wrap the drain wire around the foil. Do not remove any insulation from the conductors.
5. Align the colored wires.



**Note:**

Cord colors should be matched to the same pins on both ends of the cable.

6. Trim all wires to the same length. About 12 mm on the left should be exposed from the inner sheath.
7. Separate the wires and place the twisted shield between the separated wires.

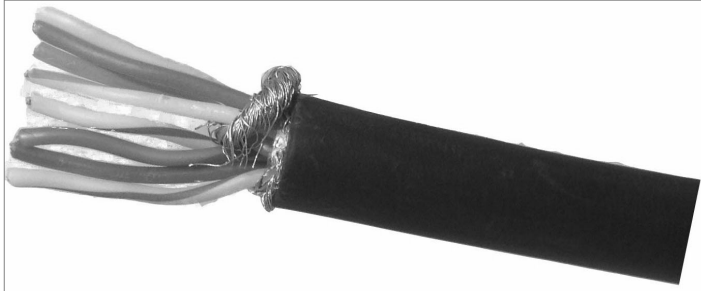

8. Insert the wires into the RJ45 plug. Verify that each wire is fully inserted into the front of the RJ45 plug and in the correct order, according to the pinouts shown in Section [Outdoor Ethernet Cable Specifications](#). The sheath of the Ethernet cable should extend into the plug by about 13 mm and held in place by the crimp.
9. Extend the cable jacket with the shield into the connector about 5 mm for strain relief and shielding connection.

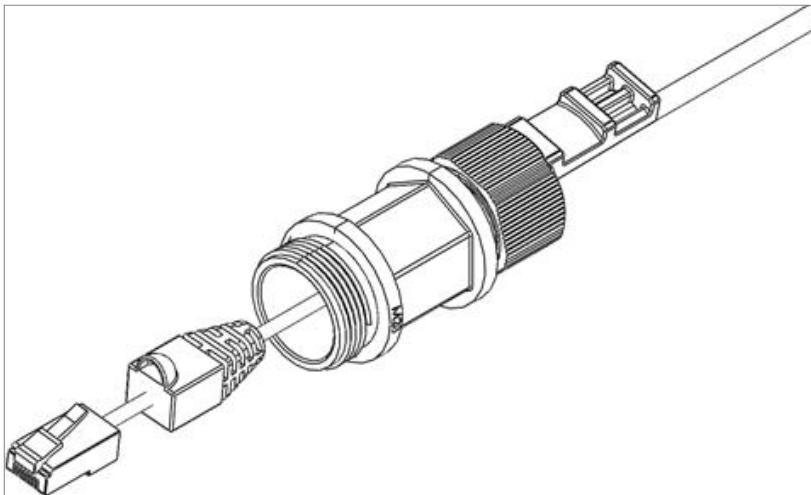

10. Wrap the twisted braid firmly around the cable jacket and let the crimping tail of the RJ45 plug envelop it.



**Note:**

To ensure proper grounding, it is essential that the twisted braid be firmly connected to the RJ45 plug.



11. Crimp the RJ45 plug with the crimp tool. Make sure the twisted shield is crimped firmly to the RJ45 plug.

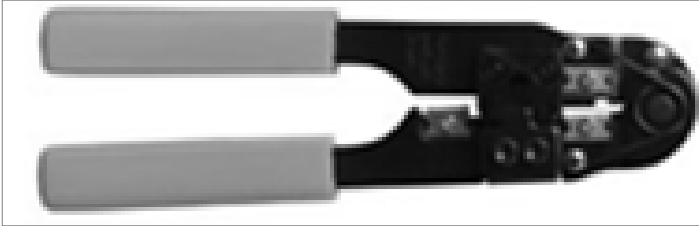

12. Verify that the wires ended up the correct order and that the wires extend to the front of the RJ45 plug and make good contact with the metal contacts in the RJ45 plug.
13. Push back the CAT5E plug cover on the connector plug.



**Note:**

It is recommended that the newly prepared cable be tested with a Cable Analyzer such as the FLUKE DTX-1800 (or the equivalent), to make sure the cable complies with ANSI/TIA/EIA-568-B-2. Make sure to verify both connectivity and grounding continuity at both ends of the cable.

## Preparing the Ethernet Cable Already Assembled

To prepare the Ethernet cable already assembled:

1. Release the gland cap and the gland rubber slightly.

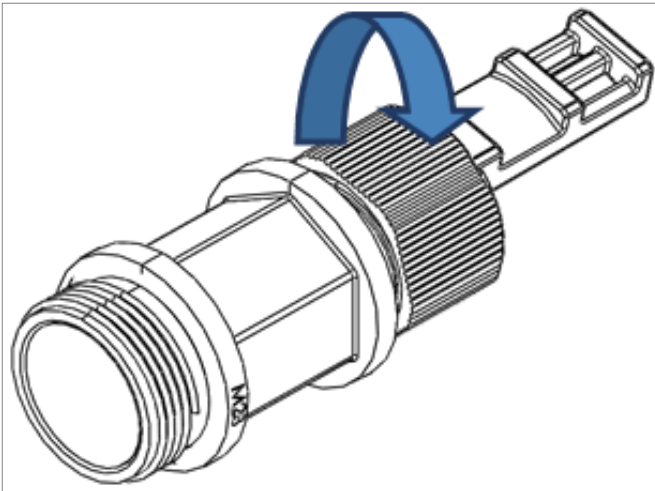

2. Insert the CAT5E cable into the gland cap and into the rubber gland.

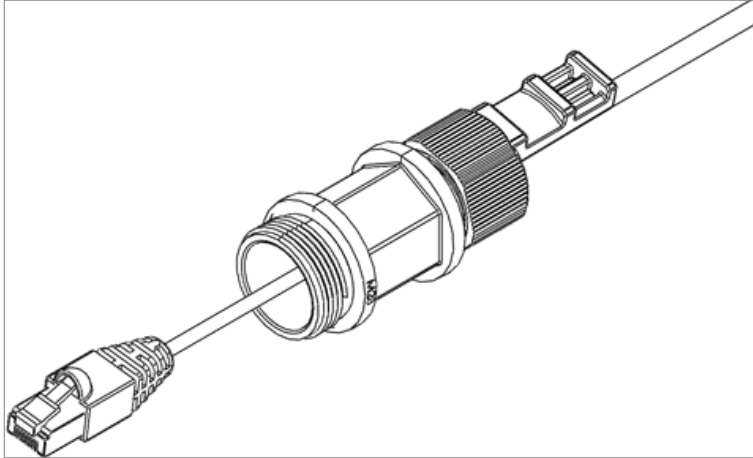

3. Insert the CAT5E cable into the gland body.

## Connection of Ethernet Cable to PTP 850CX

To connect the Ethernet cable to the PTP 850CX:

1. Remove the relevant cap from the PTP 850CX radio. You can use the side of the gland to unscrew the cap.
2. Connect the CAT5E cable to the PTP 850CX.

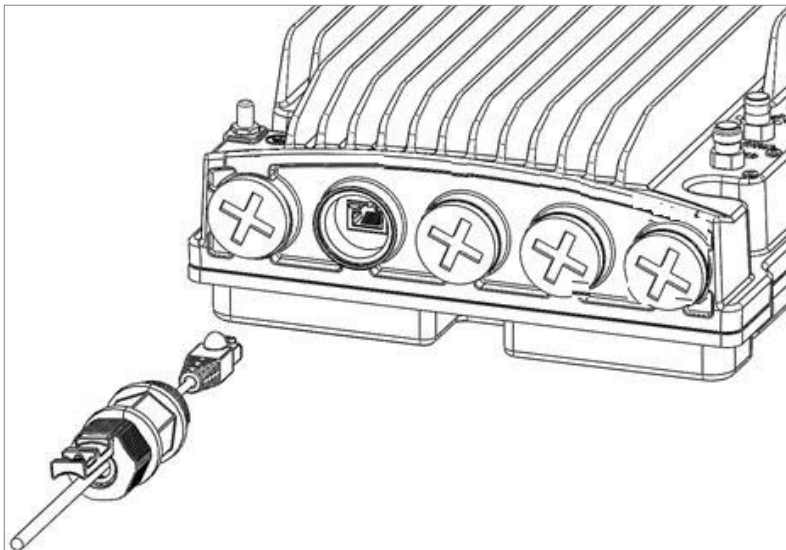

3. Screw the gland into the radio unit.



**Note:**

Before tightening the gland, make sure the gland is even with the cover. Tighten the gland gently and make sure there is no resistance. If there is resistance, stop immediately and verify that the gland is not being inserted at an angle. Tightening the gland at an angle can ruin the thread on the gland and prevent proper sealing of the

interface.

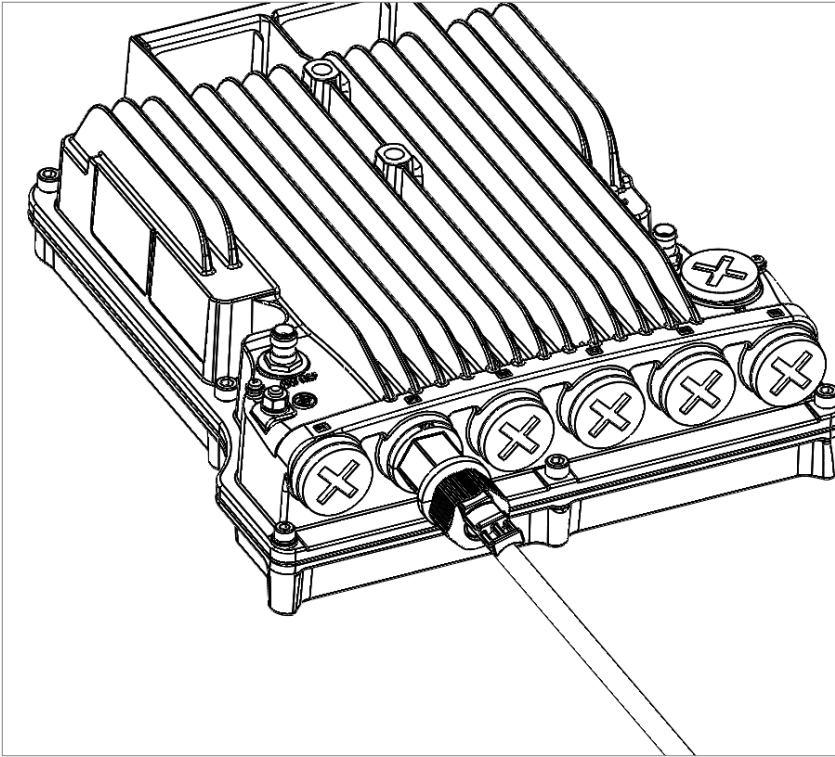

- 4. Tighten the gland cap.
- 5. Secure the cable to the gland using a tie wrap.

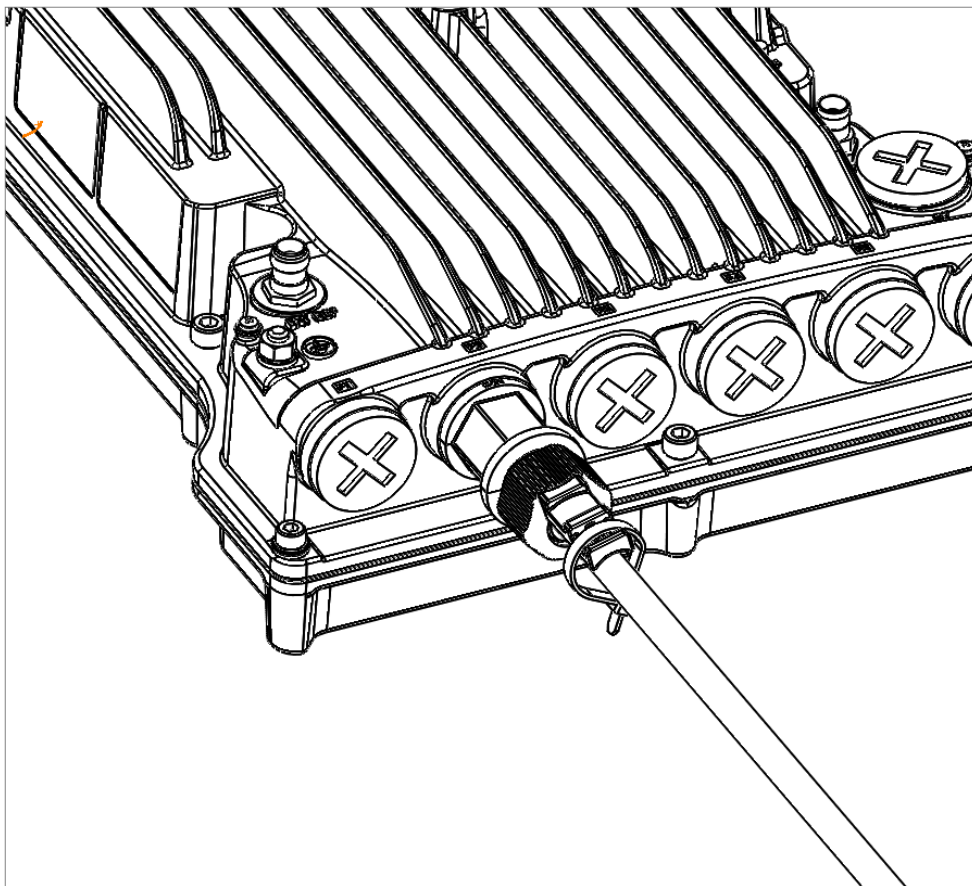

## Management Connection for 1+1/2+2 HSB Configurations

In HSB protection configurations, two Y-splitter cables and a special signaling cable must be used to connect the management ports (MGT/PROT) of the two PTP 850CX units and provide management access to each unit.

The Protection signaling cables are available pre-assembled from Cambium in various lengths, but users can also prepare them in the field.

The following sections explain how to prepare and connect these cables.

### Preparing a Protection Signaling Cable

The Protection signaling cables require the following pinouts.

**Figure 18:** Protection Signaling Cable Pinouts

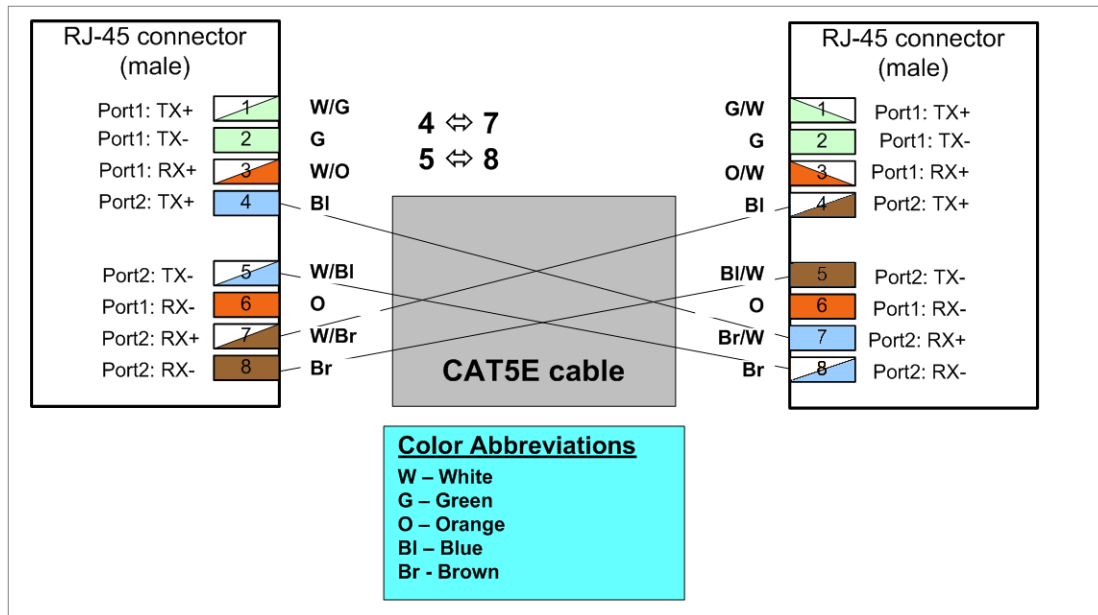

**Note:** Other than the pinout connection described above, the cable should be prepared according to the cable preparation procedure described in [Connecting the Ethernet Cable](#).

## Connecting the Protection Splitters and Protection Signaling Cable

Each splitter has three ports:

- System plug (“Sys”) – The system plug should be connected to the PTP 850CX’s MGT/Prot port (P5).
- Management port (“Mng”) – A standard CAT5E cable should be connected to the splitter’s management port in order to utilize out-of-band (external) management.



**Note:** Even for systems that use in-band management, initial configuration of any HSB protection configuration must be performed manually using out-of-band management.

- Protection signaling port (“Prot”) – A Protection signaling cross cable, as described above, should be connected between this port and the other “Prot” port of the second splitter on the mate PTP 850CX unit.

The following figure demonstrates a 2x2 HSB configuration in which both PTP 850CX units are connected to an external management station and to each other, using two splitters.

**Figure 19:** 2x2 HSB Protection Configuration with External Management

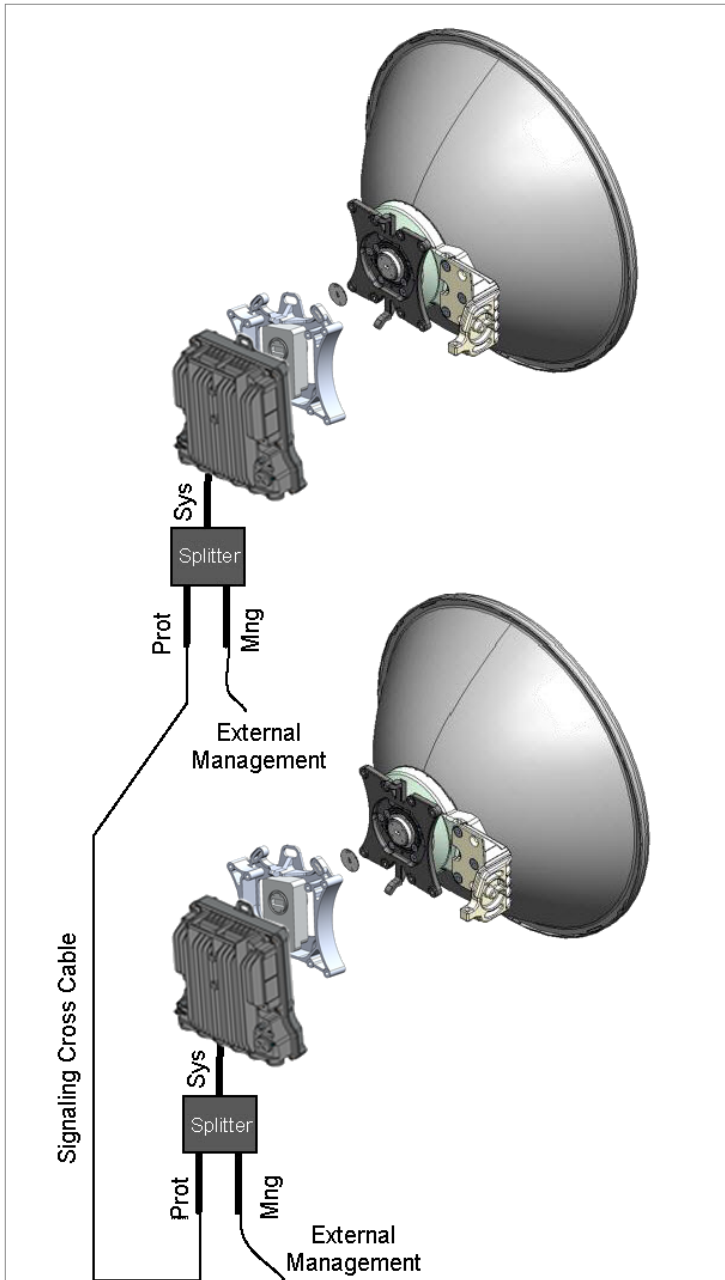

# PoE Injector Installation and Connection

## PoE Injector Cable Connection

The PoE Injector cables are connected similar to the PTP 850CX.

- To connect the Ethernet (CAT5E) cable to the PoE or Data port, refer to [Connection of Ethernet Cable to PTP 850CX](#).
- To connect the DC power cable to the power port or dual feed port, refer to [Connecting a DC Power Cable](#). This cable is not supplied with the PoE Injector.
- The total length of the cable between the PTP 850CX port and the Switch/Router the device is connected to should not exceed 100m/328ft. This length includes the connection between the PTP 850CX and the PoE Injector ( $X1 + X2 \leq 100\text{m}/328\text{ft}$  in the figure below).



**Note:**

The length of the cable connecting the customer equipment to the PoE injector should not be longer than 10m (according to ANSI/TIA-568 standard).

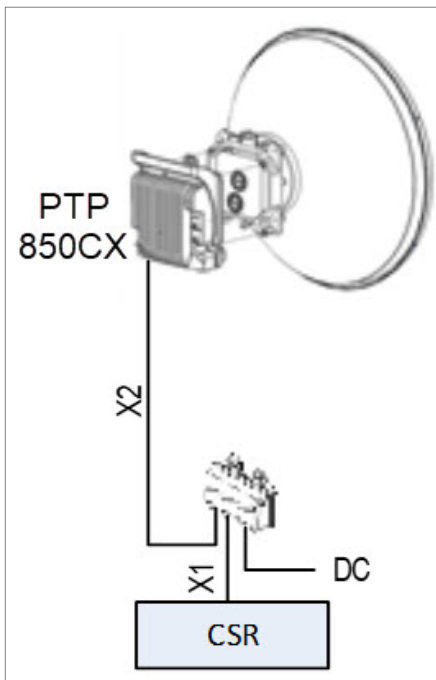

**Note:**

For the warranty to be honored, the connection must be through the glands only. Do not open the PoE injector box cover.

## PoE Injector Grounding

To ground the PoE Injector:

1. On the right side of each PoE Injector, loosen the screw, plain washer, and serrated washer.
2. Place the cable lug (supplied with the PoE injector kit) between the plain and serrated washer.
3. Tighten the screw.
4. Perform a resistance test between the 2 lugs of the GND cable. Verify that the result is 0-2 ohms.

## PoE Injector Wall Mount Installation

### List of Items

Item	Description	Quantity	Remarks
1	PoE Injector	1	
1	Glands Kit	1	For outdoor installations.



**Note:**

Glands are required for outdoor installations. The glands kit (three or five glands) is not supplied with the PoE Injector, and must be ordered sep

### Glands Kit

Marketing Model	Marketing Description
N000082L100A	KIT 3pcs of M28 GLAND (AA-0597-0)
PTP 820_Glands_kit	PTP 820_Glands_x5_kit

### Required Tools

- Metric offset wrench key wrench set
- Hammer
- Drilling Machine

### Procedure

1. Mount and tighten the PoE Injector to a wall using two M6 bolts and anchors. The M6 bolts and anchors must be purchased separately.



**Note:**

Use Anchor Stainless Steel with flanged Hexagonal nut M6X70.

2. Drill two 6mm diameter holes with 100mm distance between the centers of the holes.
3. Insert the anchors with the bolts.
4. Place the washers on the bolt.
5. Tighten the nuts.

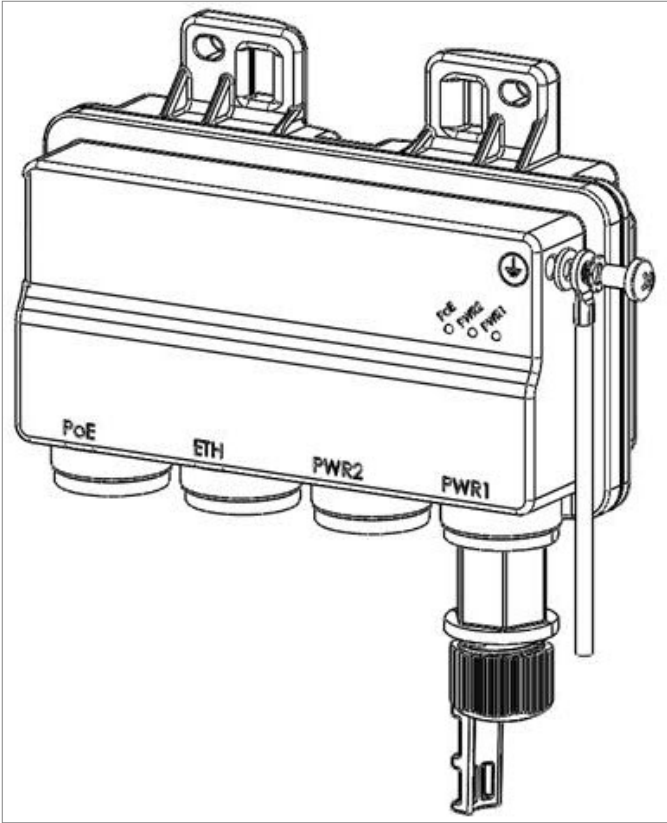
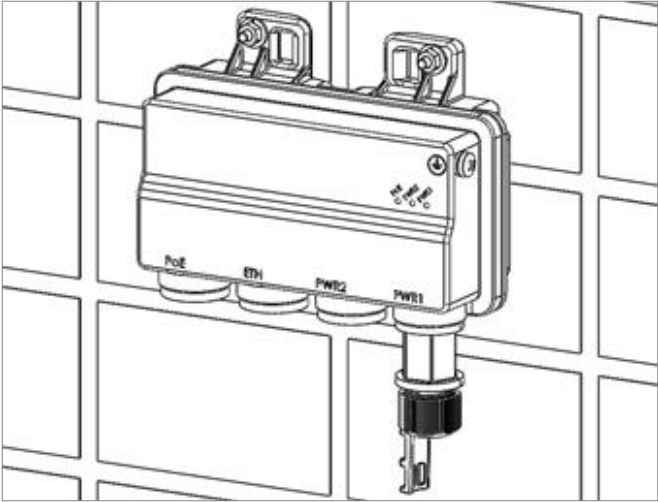
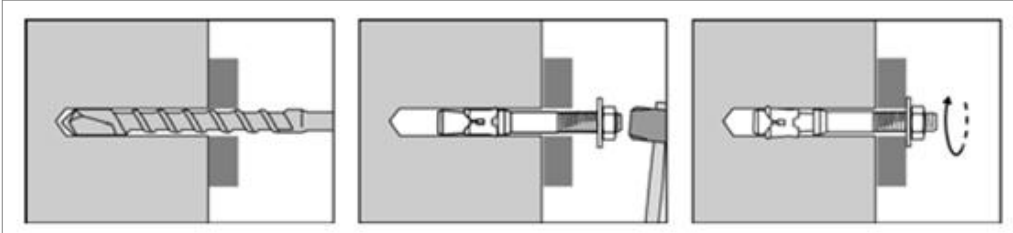

# PoE Injector Pole Mount Installation

## List of Items

Item	Description	Quantity	Remarks
1	PoE Injector	1	

## Required Tools

- Slot Screwdriver

## Procedure

To mount the PoE Injector on a pole:

1. Mount and tighten the PoE Injector to a pole with a diameter of 114 mm using a stainless steel hose clamp.
2. Pass the hose clamp through the pole mount slots.



### Note:

The Hose Clamp is not supplied with PoE injector kit.

3. Attach the PoE injector to the pole.
4. Connect the ends of the hose clamp.
5. Tighten the hose clamp using the captive screw.

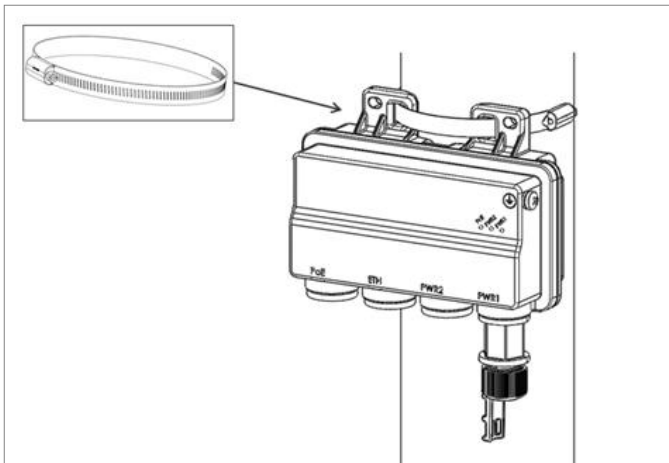

# PoE Injector 19" Rack Installation

## List of Items

Item	Description	Quantity	Remarks
1	PoE Injector	1	
2	PoE Injector 19" Rack Mount Kit	1	

## Required Tools

- Philips Screwdriver

To mount the PoE Injector on a rack:

1. Mount the PoE Injector to a 19" rack using a 19" rack adaptor.
2. Mount the PoE Injector on the 19" adaptor through the wall mounting holes, using M6 screws and washers.

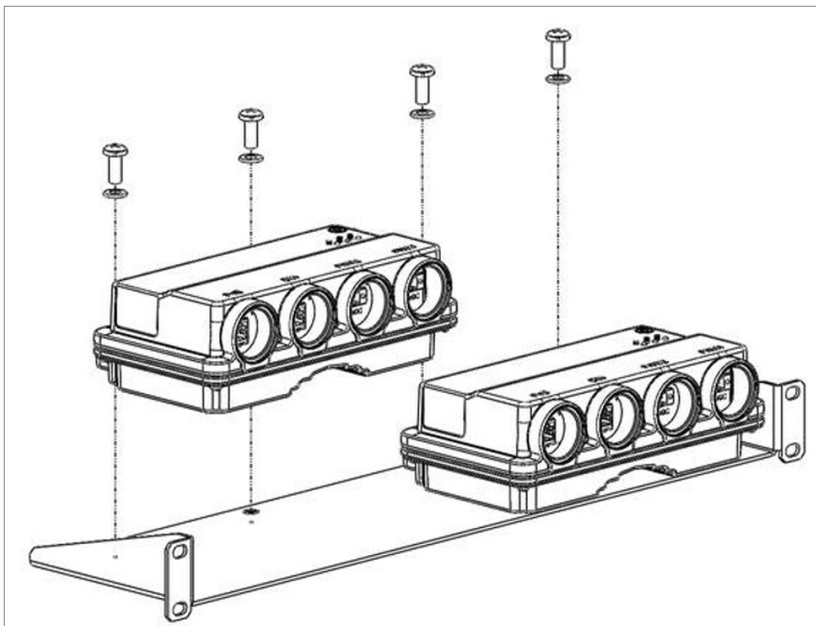

3. Mount the 19" rack adaptor to a 19" rack using four M6 screws and cage nuts.

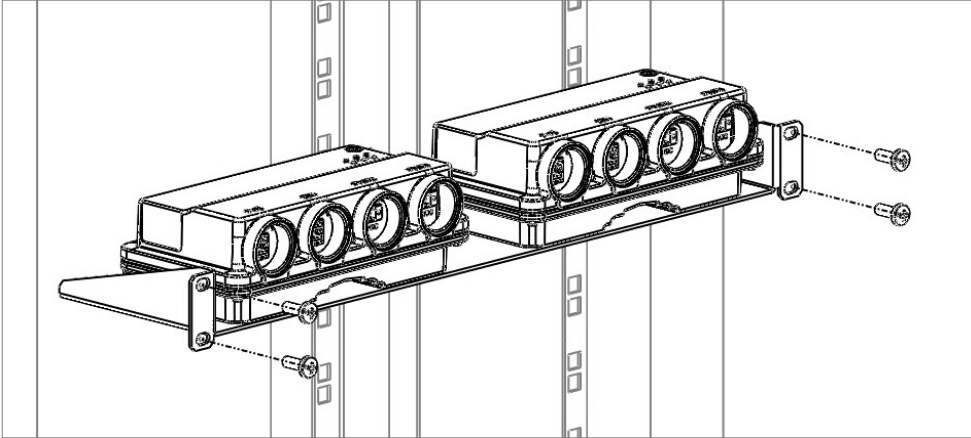

## PoE Injector ETSI Rack Installation

### List of Items

Item	Description	Quantity	Remarks
1	PoE Injector	1	
2	PoE Injector ETSI Rack Mount Kit	1	

### Required Tools

- Philips Screwdriver

To mount the PoE Injector to an ETSI rack:

1. Mount the PoE Injector to an ETSI rack using a 19" rack adaptor and ETSI adapting ears.
2. Connect the ETSI adapting ears to a 19" rack adaptor using four M6 screws.

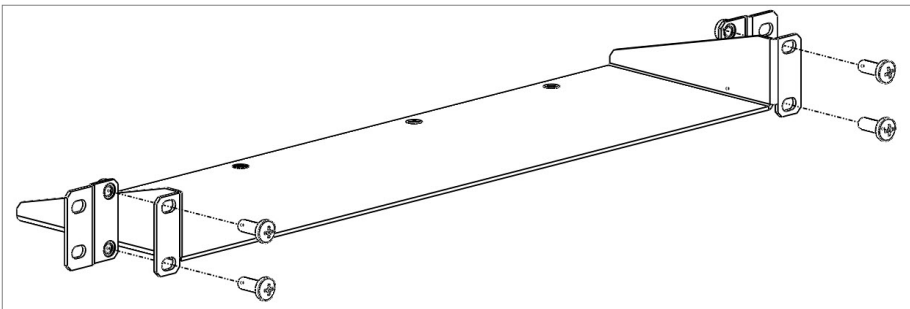

3. Mount the PoE Injector on the adaptor through the wall mounting holes using M6 screws and washers.

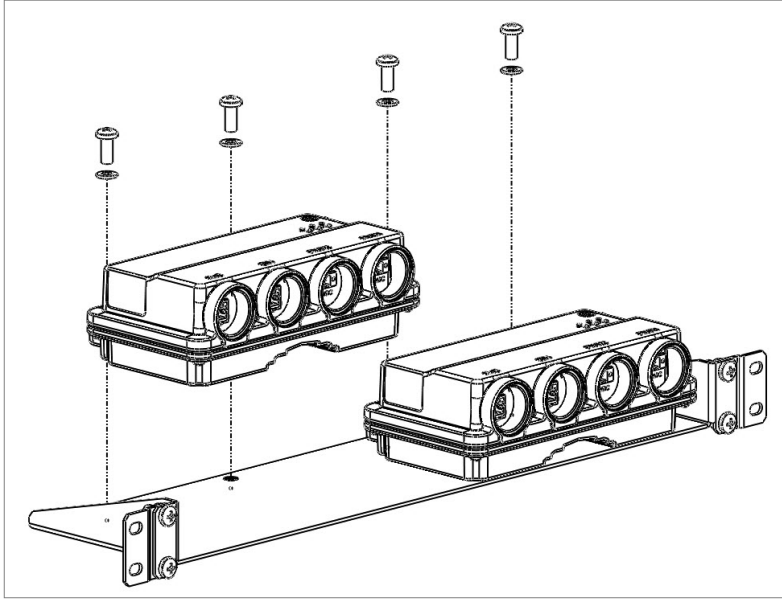

4. Mount the 19" rack adaptor with the ETSI ears on the ETSI rack using four M6 screws and cage nuts.

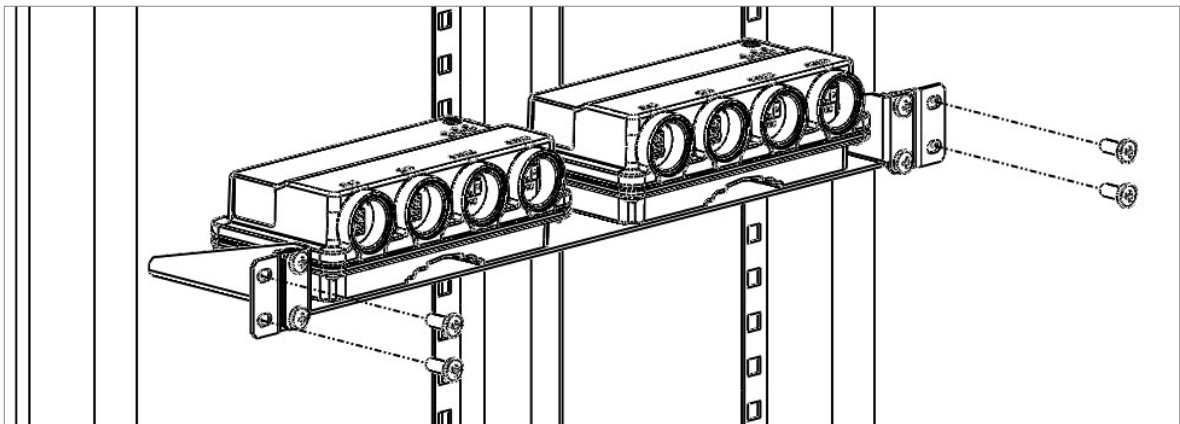

**Note:**

For this type of installation, a 2RU space is required.

# Generic Installation Procedures

## General Notes Concerning All Installation Procedures

Since the PTP 850CX architecture is of a Dual Core nature, each dual core configuration can be considered as single core configuration hardware ready for its dual core counterpart. Therefore, you should follow the same procedure for *2+0 SP* installation, if you want to install a *1+0 SP HW ready for 2+0 SP*.

One of the major benefits of the PTP 850CX and the dual core architecture is that upgrading can be done remotely by uploading the correct software license.

Before starting an installation, use a leveler to make sure that the poles are 100% vertical. You need to check both sides of each pole at 90 degrees separation. This is a critical step in any link but most important when installing MIMO or XPIC.



**Note:**

Do not remove the transparent pressure windows located on the antenna interfaces.

**Figure 20:** *Transparent Pressure Windows*

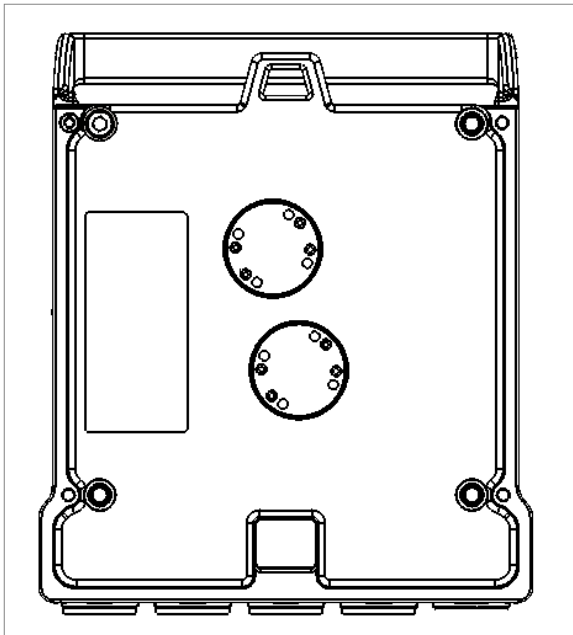

## XPIC-Ready 1+0 Links

When installing a 1+0 link which is hardware ready for 2+0 Dual Polarization (XPIC), make sure to plan and install the link as if it is immediately being configured as an XPIC link. This includes both link budget calculation and hardware installation.

The OMT must be carefully aligned according to the XPIC alignment procedure. Use activation key Demo Mode to activate the second radio interface for purposes of alignment. After completing alignment, install the regular activation key and configure the PTP 850CX unit for 1+0 operation.

Failure to follow these steps may limit your ability to upgrade a 1+0 link to a 2+0 XPIC link at a later date from a remote location.

## Torque Requirements

When tightening the captive screws, use 20 Nm torque for radio-antenna, radio-mediation device, and mediation device-antenna connections. In order to avoid misalignment, screws should be tightened progressively.

For installing the diplexer unit on the radio, use 5 Nm torque.

When fastening a waveguide to the radio or mediation device, use the following torque, according to frequency and screw type:

- 6 GHz: M5/#10-32: 3.5 Nm
- 7/8-15 GHz: M4/#8-32: 2.5 Nm
- 18-42 GHz: M3/#4-40: 1Nm

In addition, when connecting the diplexer to the radio and the radio to the mediation device, screws should be cross-tightened gradually. In other words, partially tighten one screw, then partially tighten the opposite screw. For example, if you start with the screw on the upper left, proceed to the screw on the lower right, then the upper right, then the lower left. Tighten each screw partially, then in the same order, tighten the screws further until each screw is fully tightened.

## Installing the Diplexer Unit on the Radio

For frequencies of 6 to 11 GHz, the PTP 850CX and Diplexer Unit are delivered as two separate components: a generic radio unit and a diplexer unit. This section explains how to attach the diplexer unit to the radio unit.



**Note:**

Mounting of the diplexer unit to the radio unit should be performed by certified personnel in a clean, temperature and humidity-controlled environment.

### List of Items

Item	Description	Quantity	Remarks
1	PTP 850CX Basic Radio Unit	1	
2	PTP 850CX Diplexer Unit	1	

### Required Tools

- Torque Wrench With Metric Hexagon Socket Key Wrench #4 (Allen Key)

## Procedure



**Note:**

Do not remove the transparent pressure windows located on the antenna interfaces.

**Figure 21:** *Transparent Pressure Windows*

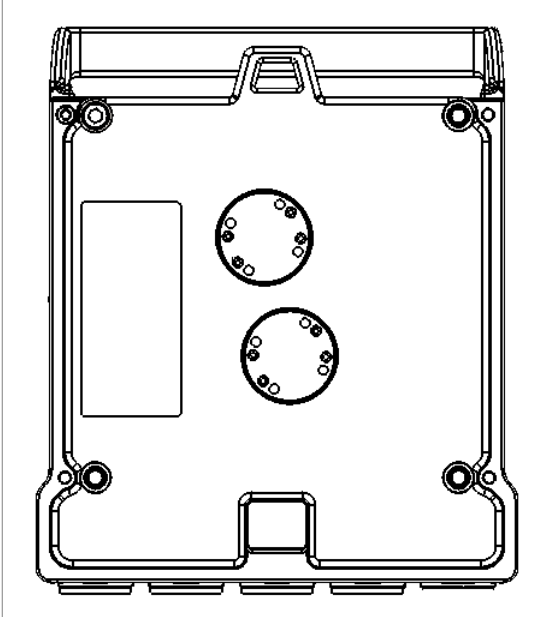

1. Align the diplexer unit to the radio unit using the two alignment pins located on the TRX ports of the radio unit and secure the diplexer unit to the radio unit using the four M5 captive screws which are pre-assembled on the radio unit.



**Note:**

Make sure the small blue cable is straight and tucked underneath the diplexers so that it does not interfere with the assembly.

**Figure 22:** *Attaching the Diplexer*

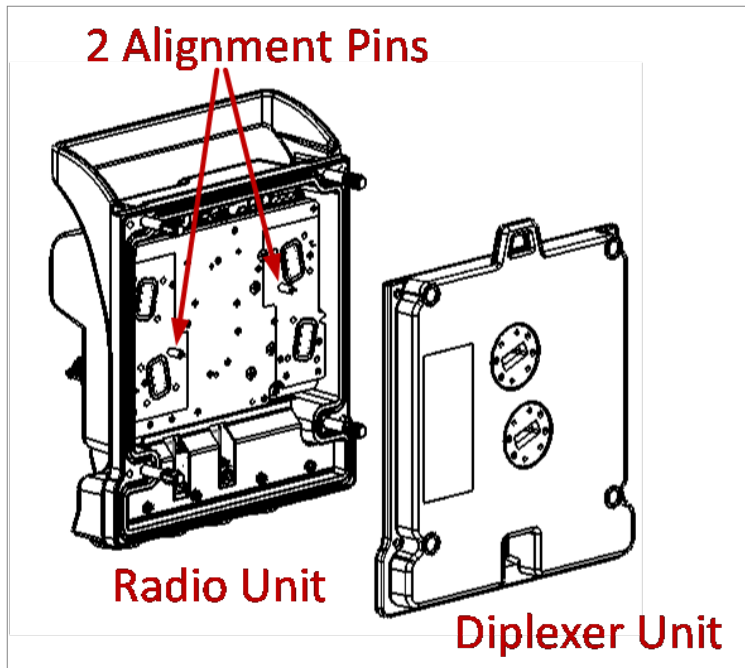

2. Tighten the M5 captive screws on the radio from the diplexer side (back) of the radio. First, partially tighten the screws starting with the upper right and proceeding according to the order in the figure below. Then, finish tightening the screws in the same order.

**Figure 23:** *Tightening the Screws From the Diplexer Side Unit*

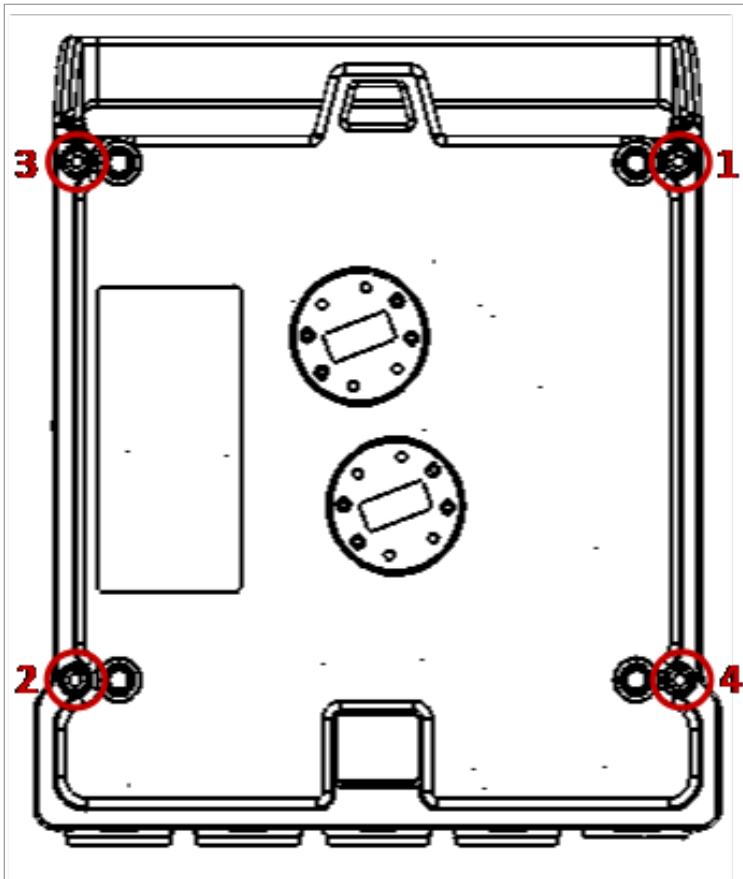

3. Make sure the four M8 installing screws are assembled on the front of the radio unit.  
M8 Installing Screws

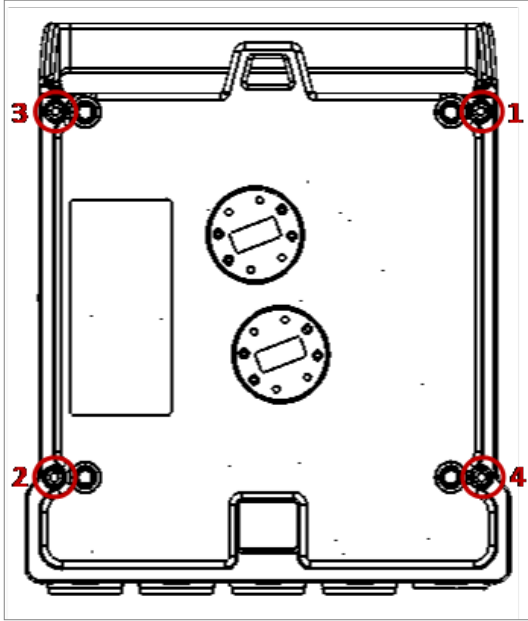

4. Proceed to install the PTP 850CX in the desired configuration, as described in [Installation Procedures per Configuration Type](#).

## PTP 850CX DC Pole Mount Procedure



**Note:**

The pole diameter range for pole mount installations is 8.89 cm – 11.43 cm (3.5 inches – 4.5 inches).

### List of Items

Item	Description	Quantity	Remarks
1	PTP 820C DC POLE MOUNT KIT	1	
2	PTP 820C DC REMOTE MOUNT ADAPTOR KIT	1	13GHz

### Required Tools

- Metric offset wrench key wrench set

To install the PTP 820C pole mount:

- Mount and tighten the PTP 820C DC pole mount to a pole with a diameter of 114 mm using the four washers and screws supplied with the PTP 820C DC pole mount kit.

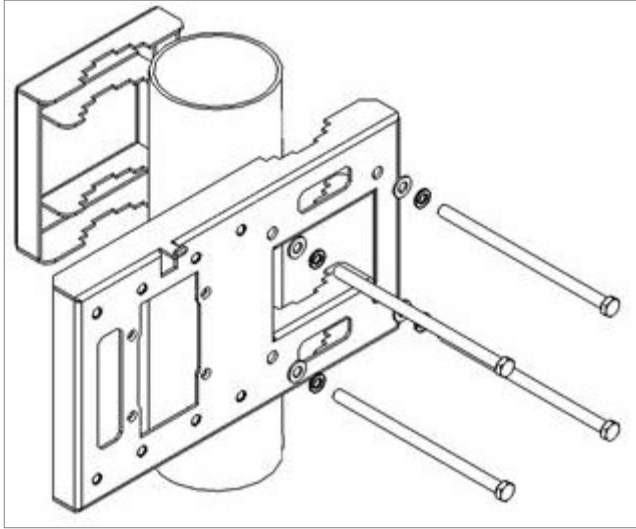

- For 13 GHz Only

Mount and tighten the PTP 820C Remote Mount Adaptor plate (supplied in PTP 820C Adaptor Remote Mount kit) to the PTP 820C Pole Mount using the four flat screws supplied with the PTP 820C Adaptor Remote Mount kit.

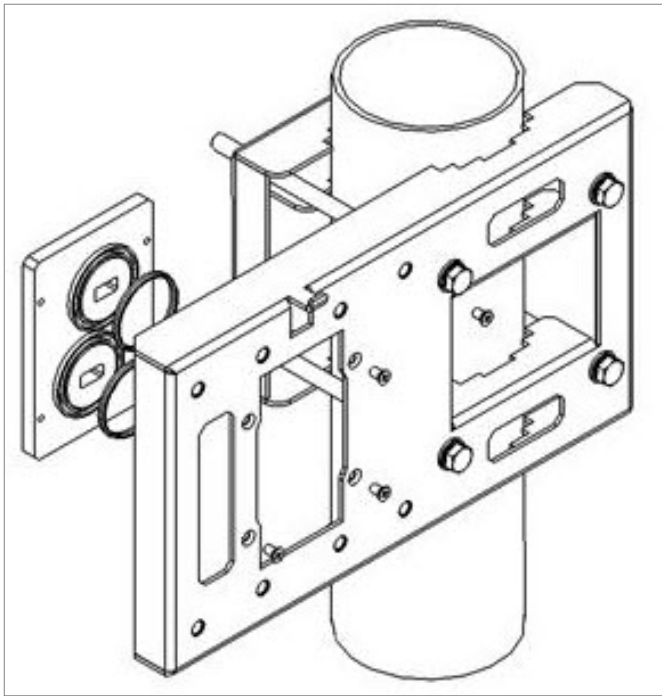

# Remote Mount Installation for Single Polarization with an Imperial Waveguide

## List of Items

Item	Description	Quantity	Remarks
1	PTP 850CX RADIO	1	
2	RFU-C ADAPTATION KIT TO FLEXIBLE WG IMPERIAL	1	13 GHz only
3	RFU-C REMOTE POLE MOUNT KIT	1	
4	PTP 820C SPLITTER KIT	1	

## Required Tools

- Metric offset hexagon key wrench set
- Imperial offset hexagon key wrench set
- Phillips #1, #2 screwdriver

## 13GHz Installation Procedure

1. Mount and tighten the RFU-C Adaptor plate (supplied in RFU-C Adaptation kit to Flexible WG Imperial) to the RFU-C Remote Pole Mount using the four flat screws supplied with the RFU-C Adaptation kit to Flexible WG Imperial.

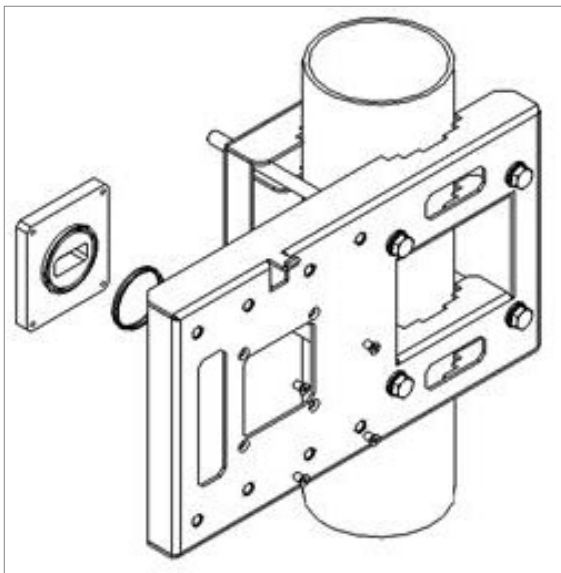

2. Mount and tighten the PTP 820C Splitter to the RFU-C Remote Pole Mount using the four captive screws and washers that are assembled to the PTP 820C Splitter kit.

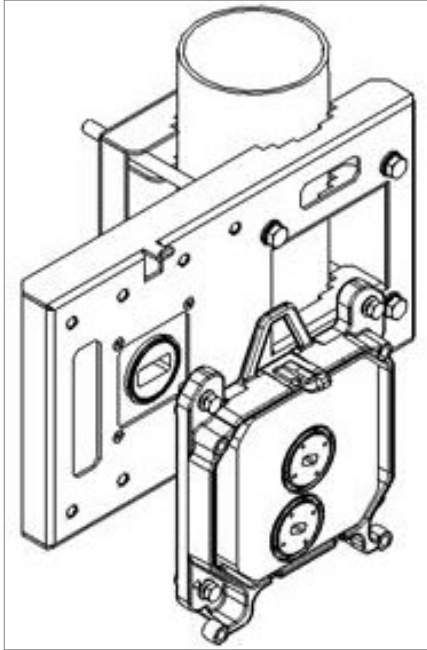

3. Mount and tighten the PTP 850CX radio to the PTP 820C Splitter using the four captive screws and washers that are assembled to the PTP 850CX radio. Pay attention that the O-rings are mounted on the PTP 820C Splitter kit.

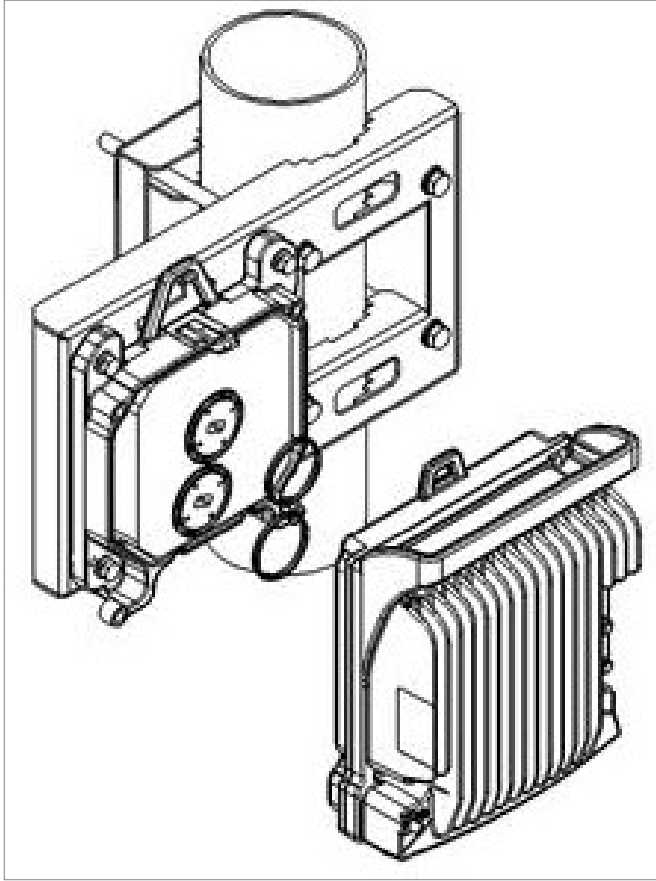

4. Connect the Flexible Waveguide and Sealing Gasket supplied with the Flexible Waveguide Imperial Kit to the RFU-C Adaptor plate. Tighten the four screws supplied with the Flexible Waveguide Imperial Kit.

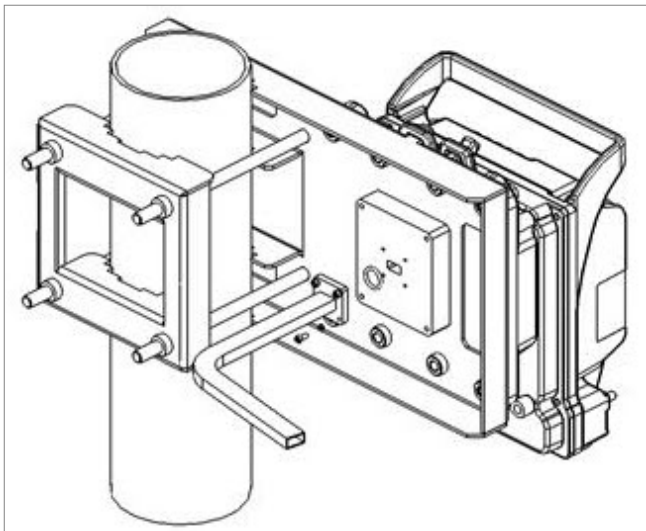

## 15-23 GHz Installation Procedure

1. Loosen the two screws, and remove the twist plate from the PTP 820C Splitter.

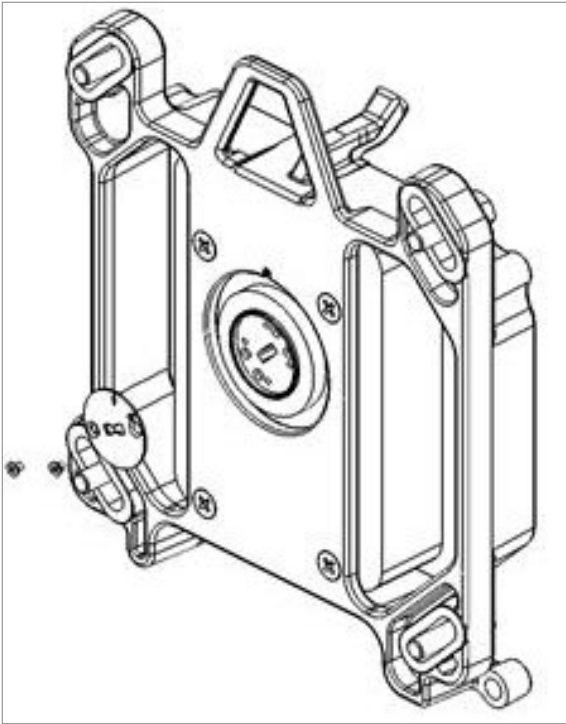

2. Mount and tighten the PTP 820C Splitter to the RFU-C Remote Pole Mount using the four captive screws and washers that are assembled to the PTP 820C Splitter kit.

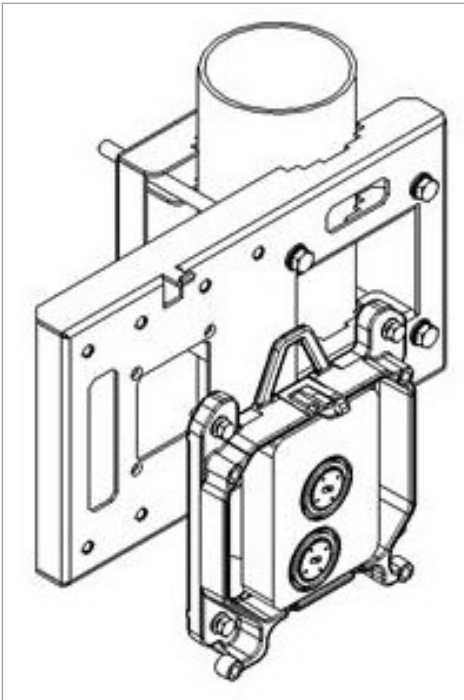

3. Mount and tighten the PTP 850CX radio to the PTP 820C Splitter using the four captive screws and washers that are assembled to the PTP 850CX radio. Make sure the O-rings are mounted on the PTP 820C Splitter kit.

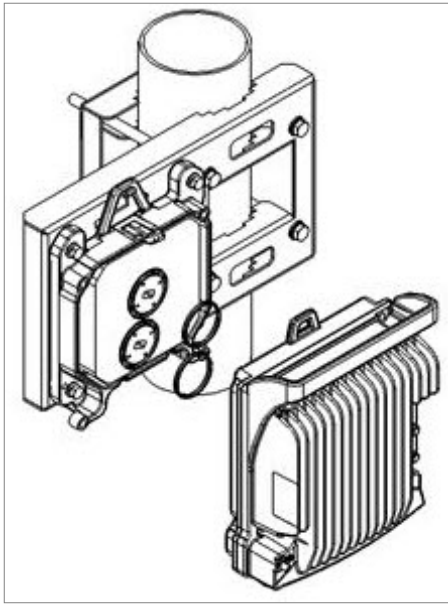

4. Connect the Flexible Waveguide and Sealing O-ring supplied with the Flexible Waveguide Imperial Kit to the IP20-C Splitter kit. Tighten the four screws supplied with the RFU-C Adaptation kit to the Flexible Waveguide Imperial.

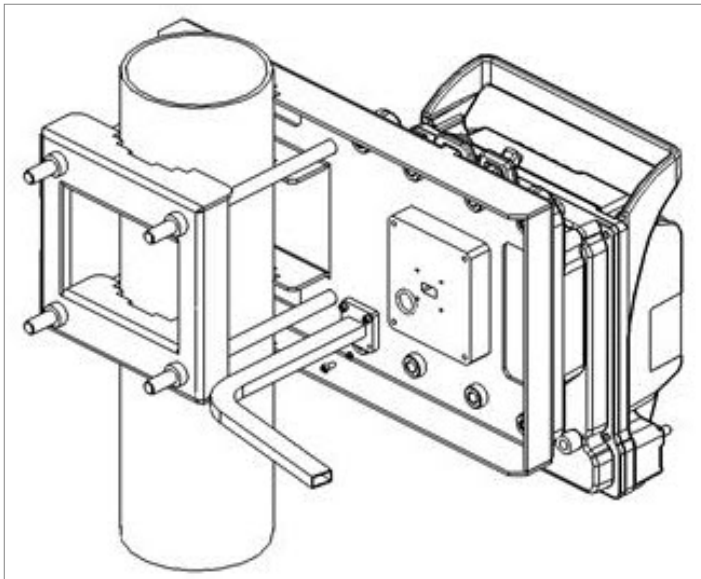

# Installation Procedures per Configuration Type

**Note:**

For instructions on configuring Multiband with PTP 850E and PTP 850CX, refer to the Installation Guide for PTP 850E.

## 2+0 Dual Polarization Direct Mount

**Note:**

This procedure can also be used for 1+0 DP HW ready for 2+0 DP configuration.

### List of Items

Item	Description	Quantity	Remarks
1	PTP 850CX Radio	1	
2	PTP 820C OMT kit	1	
3	Circ./Circ. Adaptor	1	Per Antenna Vendor

### Required Tools

- Metric offset hexagon key set
- Metric wrench key set

### Procedure

1. Prior to the installation, follow the antenna manufacturer's instructions to use the circular adaptor. (Remove the existing rectangular transition, swap the O-ring, and install the circular transition instead.)



2. Connect the OMT Kit to the antenna and secure it with four screws. Verify the existence of the O-ring.

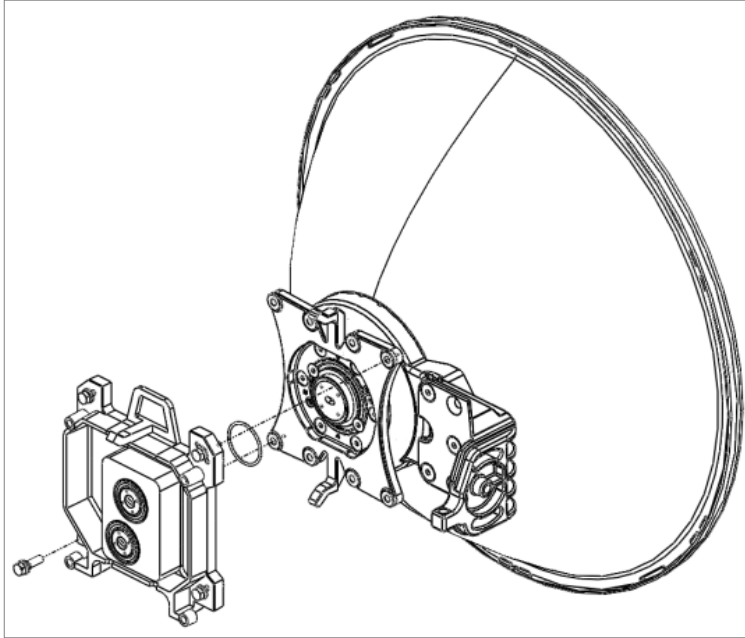

3. Connect the PTP 850CX radio to the OMT Kit using the four M8 captive screws and washers supplied, and tighten the screws.

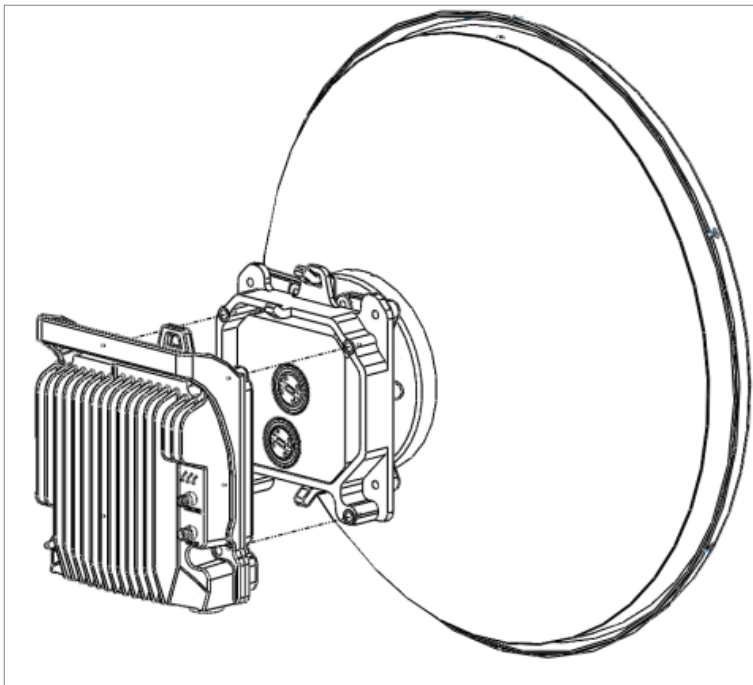

## 2+0 Dual Polarization Remote Mount

This procedure is for use with Interface antennas, up to six feet.

For standard interface antennas (six feet and larger), no OMT and no Circ./Circ. Adaptor are used, and the flexible waveguides are connected directly to the antenna flanges. For instructions how to connect the waveguides to the antenna flanges, refer to the antenna vendor's documentation.



**Note:**

This procedure can also be used for 1+0 DP HW ready for 2+0 DP configurations.

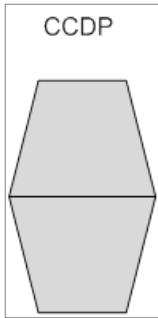

**List of Items**

Item	Description	Quantity	Remarks
1	PTP 850CX RADIO	1	
2	PTP 820C OMT kit	1	Not used for standard interface antennas (six feet and larger).
3	FLEXIBLE WG KIT	2	
4	PTP 820C DC POLE MOUNT KIT	1	
5	PTP 820C DC REMOTE MOUNT ADAPTOR KIT	1	13 GHz only
6	Circ./Circ. Adaptor	1	Per Antenna Vendor. Not used for standard interface antennas (six feet and larger).

**Required Tools**

- Metric offset hexagon key set
- Metric wrench key set
- Phillips #1, #2 screwdriver

**Common Installation**

1. Prior to the installation, follow the antenna manufacturer's instructions to use the circular adaptor. (Remove the existing rectangular transition, swap the O-ring, and install the circular transition instead.)

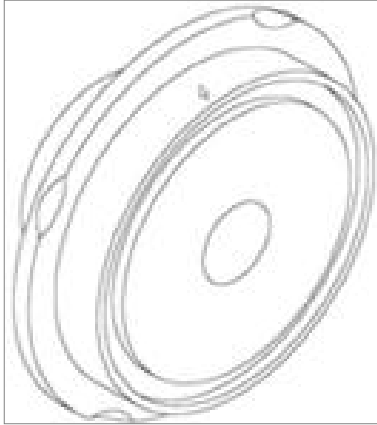

2. Connect the OMT Kit to the antenna and secure it with four screws. Verify the existence of the O-ring.

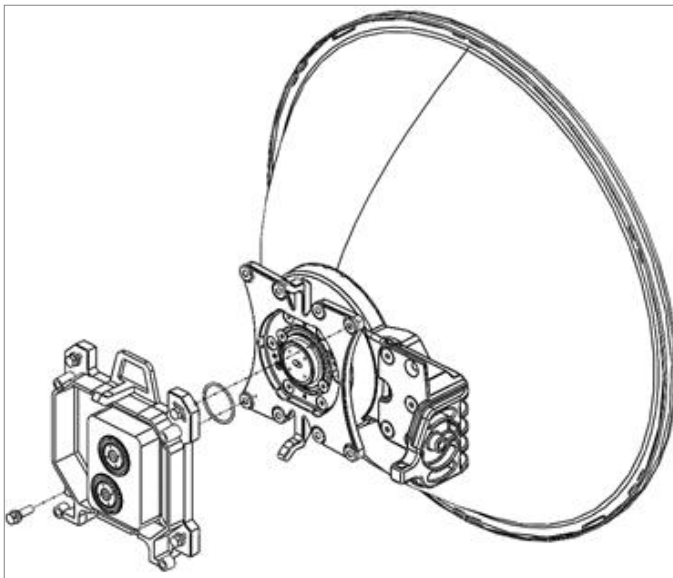

3. Mount and tighten the O-ring and the Flexible WG to PTP 820C OMT ports using the four screws supplied with the Flexible WG kit.

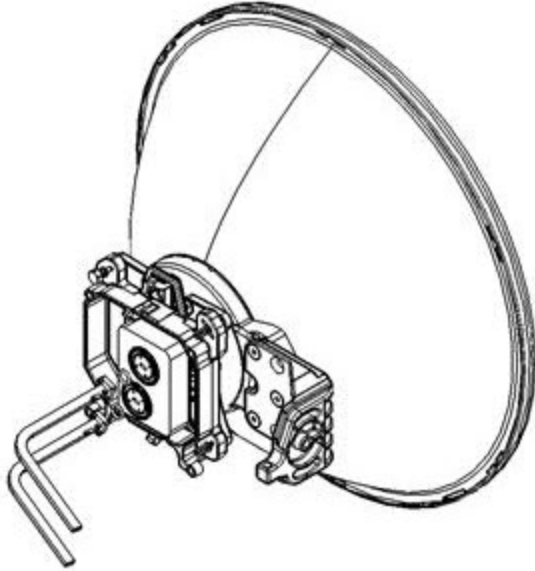

## 13 GHz

1. Mount and tighten the PTP 820C Remote Mount Adaptor plate (supplied in PTP 820C Adaptor Remote Mount kit) to the PTP 820C Pole Mount using the four flat screws supplied with the PTP 820C Adaptor Remote Mount kit.

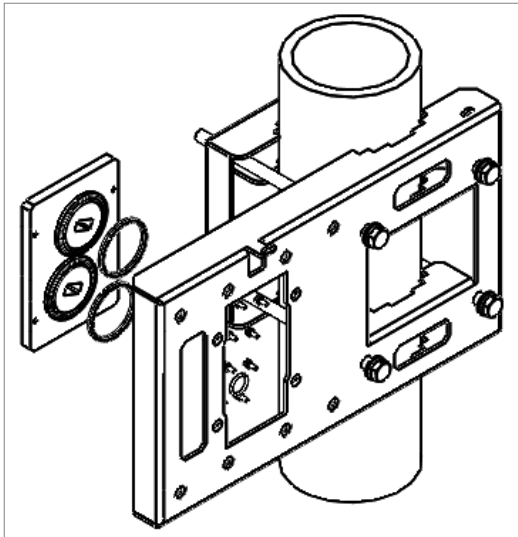

2. Mount and tighten the PTP 850CX to the PTP 820C Pole Mount using the four captive screws and washers that are supplied with the PTP 850CX. Pay attention that the O-rings are mounted on the PTP 820C Remote Mount Adaptor.

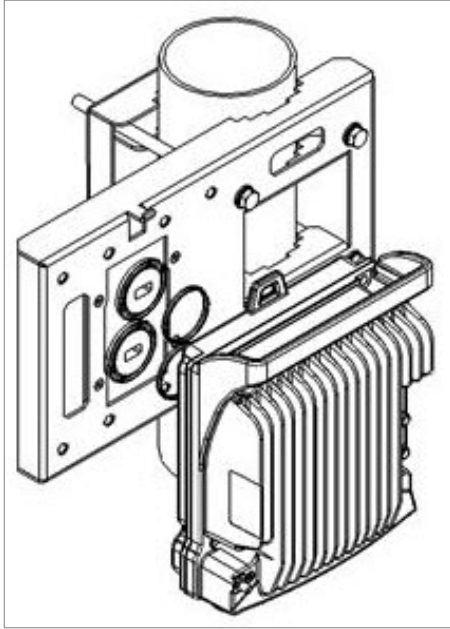

3. Mount and tighten both Flexible WGs with their O-ring to the PTP 820C Remote Mount Adaptor ports using the four screws supplied with each Flexible WG kit.

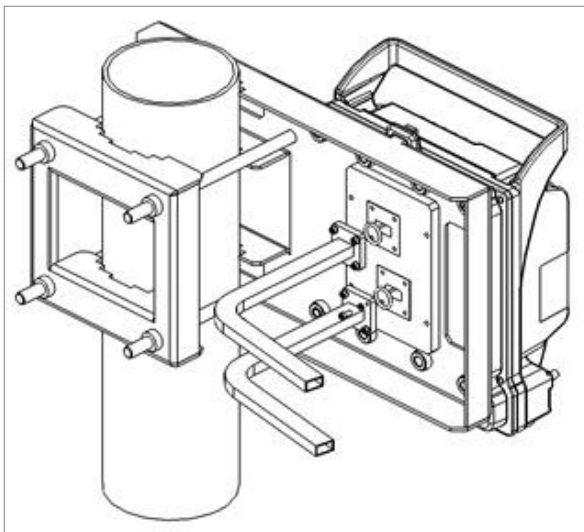

## 15-23 GHz

1. Mount and tighten the PTP 850CX to the PTP 820C DC Pole Mount using the four screws assembled on the PTP 850CX.

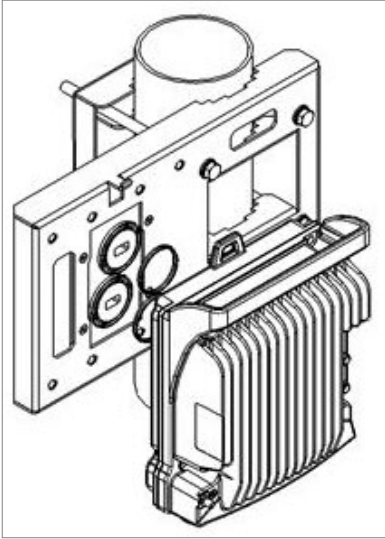

2. Mount and tighten the O-ring and the Flexible WG to PTP 850CX radio ports using the four screws supplied with the Flexible WG kit.

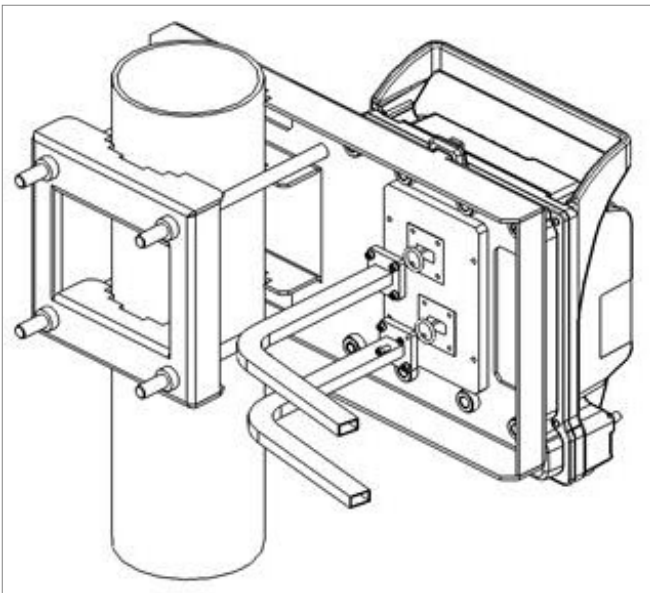

## 2+0 Single Polarization Direct Mount



**Note:**

This procedure can also be used for 1+0 SP HW ready for 2+0 SP configuration.

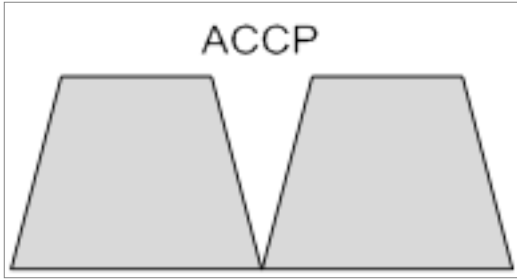

**List of Items**

Item	Description	Quantity	Remarks
1	PTP 850CX RADIO	1	
2	PTP 820C Splitter KIT	1	

**Required Tools**

- Metric offset hexagon key set
- Phillips #1, #2 screwdriver

**Procedure**

1. Adjust the twist on the Splitter Kit. Perform one of the following steps, according to the required polarization (horizontal or vertical).
  - For horizontal polarization, locate the holes above and below the letter “H” on the pins and fasten the two screws.

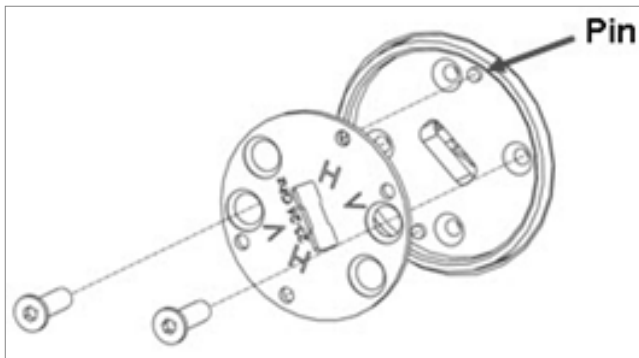

- For vertical polarization, locate the holes above and below the letter “V” on the pins and fasten

the two screws.

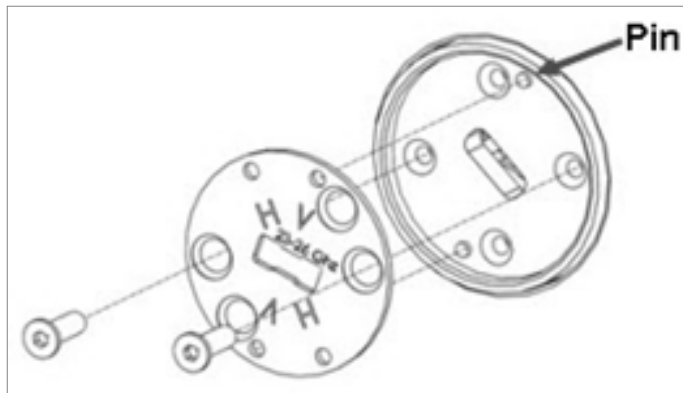

2. Mount and tighten the PTP 820C Splitter Kit on the antenna using the four M8 screws and washers.
3. Mount and tighten the PTP 850CX to the PTP 820C Splitter Kit using the four M8 captive screws and washers supplied.

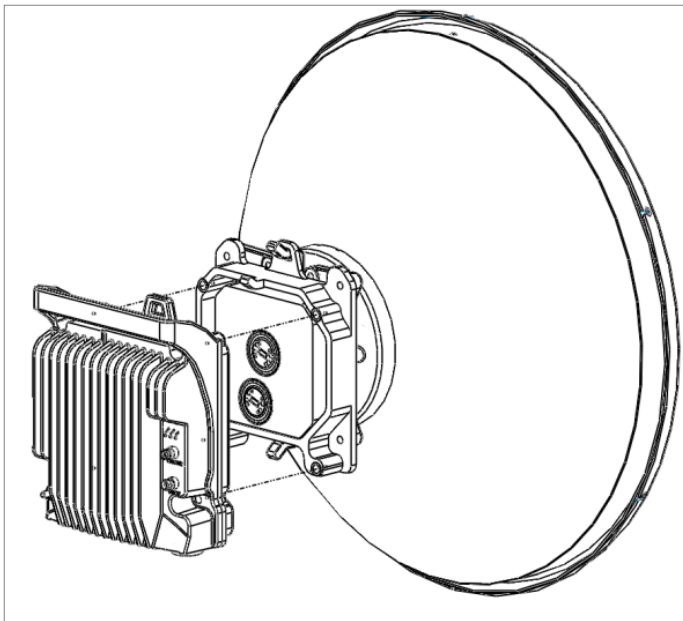

## 2+0 Single Polarization Remote Mount



**Note:**

This procedure can also be used for 1+0 SP HW ready for 2+0 SP configurations.

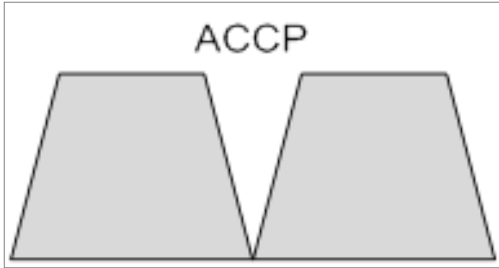

### List of Items

Item	Description	Quantity	Remarks
1	PTP 850CX RADIO	1	
2	RFU-C ADAPTOR REMOTE MOUNT KIT	1	13 GHz only
3	RFU-C POLE MOUNT KIT	1	
4	PTP 820C SPLITTER KIT	1	
5	FLEXIBLE WG KIT	1	

### Required Tools

- Metric offset hexagon key wrench set
- Phillips #1, #2 screwdriver
- Metric wrench key set

## 13 GHz

1. Mount and tighten the RFU-C Remote Mount Adaptor plate (supplied in RFU-C Adaptor Remote Mount kit) to the RFU-C Pole Mount using the four flat screws supplied with the RFU-C Adaptor Remote Mount kit.

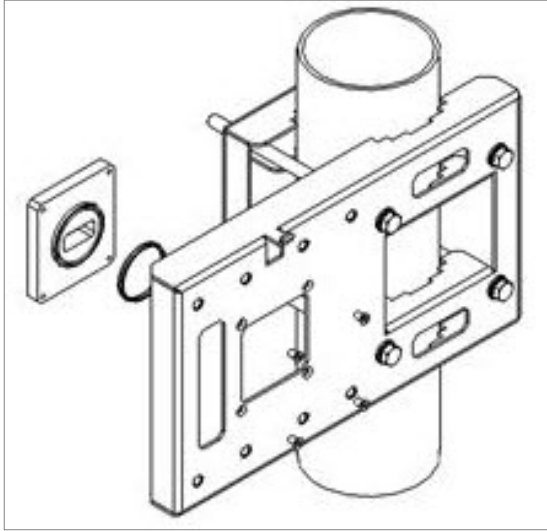

2. Mount and tighten the PTP 820C Splitter to the RFU-C Pole Mount using the four captive screws and washers that are assembled to the PTP 820C Splitter kit.

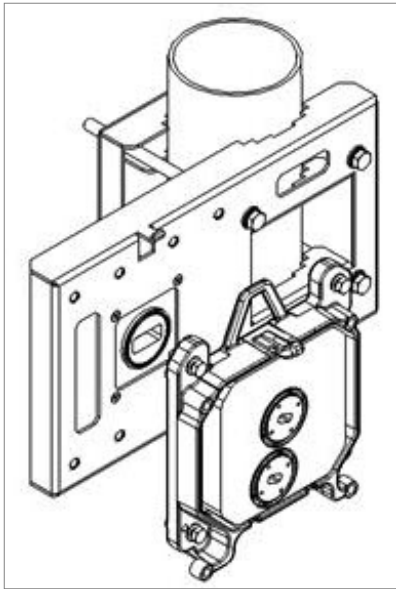

3. Mount and tighten the PTP 850CX to the PTP 820C Splitter using the four captive screws and washers that are assembled to the PTP 850CX radio. Pay attention that the O-rings are mounted on the PTP 820C Splitter kit.

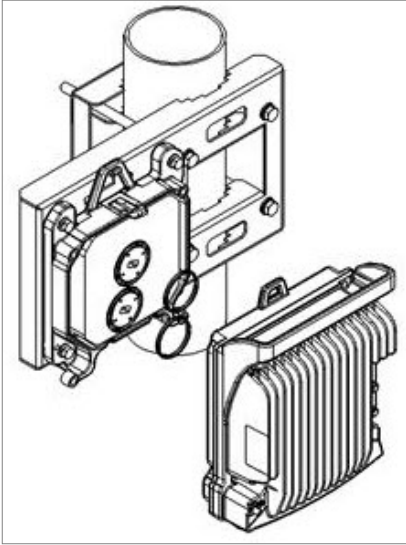

4. Connect the Flexible Waveguide and Sealing Gasket supplied with the Flexible Waveguide Kit to the RFU-C Adaptor plate. Tighten the four screws supplied with the Flexible Waveguide Kit.

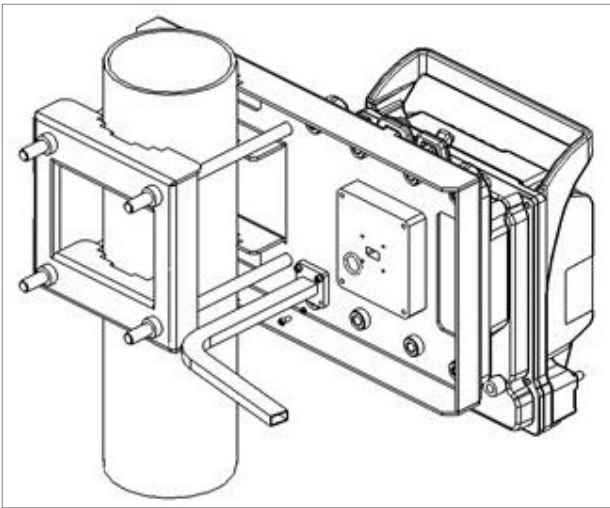

## 15-23 GHz

1. Loosen the two screws and remove the twist plate from the PTP 820C Splitter.

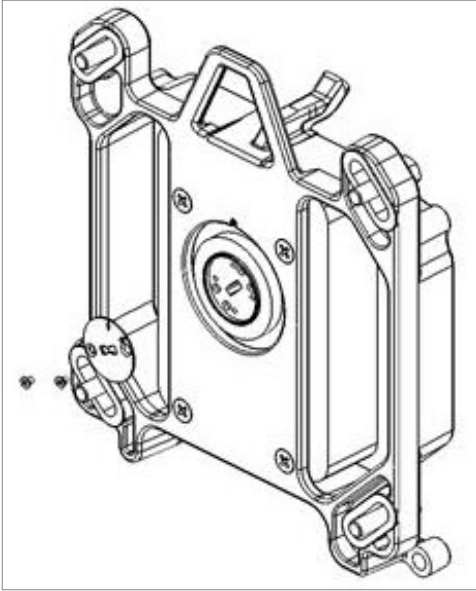

2. Mount and tighten the PTP 820C Splitter to the RFU-C Pole Mount using the four captive screws and washers that are assembled to the PTP 820C Splitter kit.

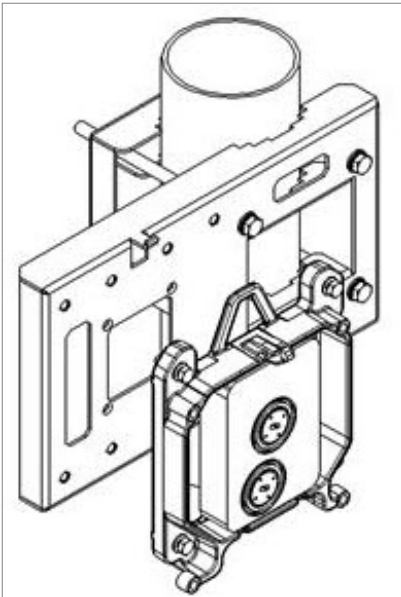

3. Mount and tighten the PTP 850CX to the PTP 820C Splitter using the four captive screws and washers that are assembled to the PTP 850CX. Pay attention that the O-rings are mounted on the PTP 820C Splitter kit.

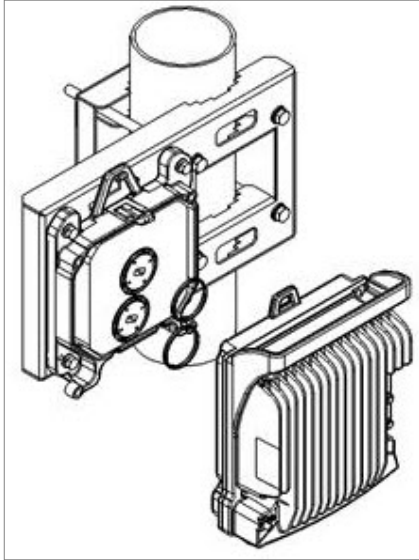

4. Connect the Flexible Waveguide and Sealing Gasket supplied with the Flexible Waveguide Kit to the IP20-C Splitter kit. Tighten the four screws supplied with the Flexible Waveguide kit.

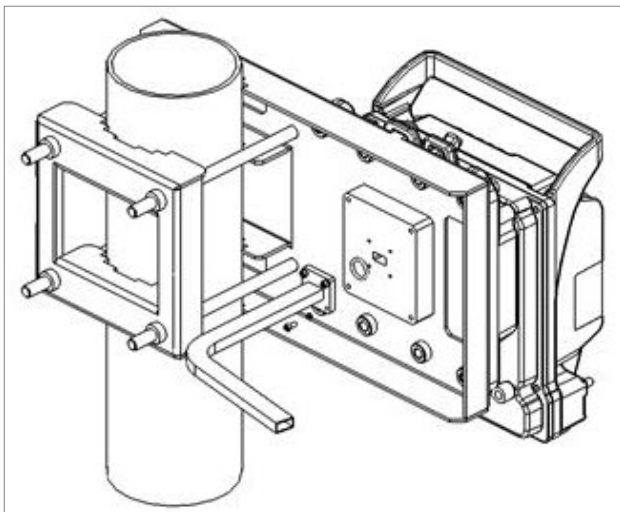

## 4+0 Layer 1 Link Aggregation, Direct Mount

### List of Items

Item	Description	Quantity	Remarks
1	PTP 850CX RADIO	2	
2	PTP 820C OMT KIT	1	
3	PTP 820C DUAL SPLITTER KIT	1	
4	SFP Transceiver	2	SFP transceiver for connection between units

Item	Description	Quantity	Remarks
5	Optical Cable for transmitting traffic between the units	1	See <a href="#">Table 25</a>



**Note:**

If a non-circular antenna interface is used, add a circular adaptor to this list of items, as described in Step 1.

**Required Tools**

- Metric offset hexagon key set
- Metric wrench key set

**Procedure**

1. If an antenna with a non-circular antenna interface is used, then prior to the installation, follow the antenna manufacturer’s instructions to use the circular adaptor. (Remove the existing rectangular transition, swap the O-ring, and install the circular transition instead.)



2. Connect the PTP 820C OMT Kit to the antenna and secure it with four screws. Verify existence of the O-ring.

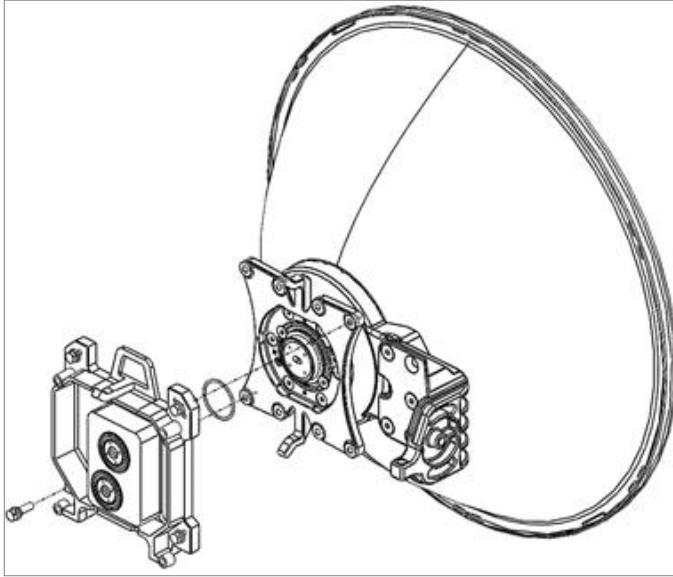

3. Connect the PTP 820C Dual Splitter Kit to the OMT Kit using four M8 screws and washers, and tighten the screws.

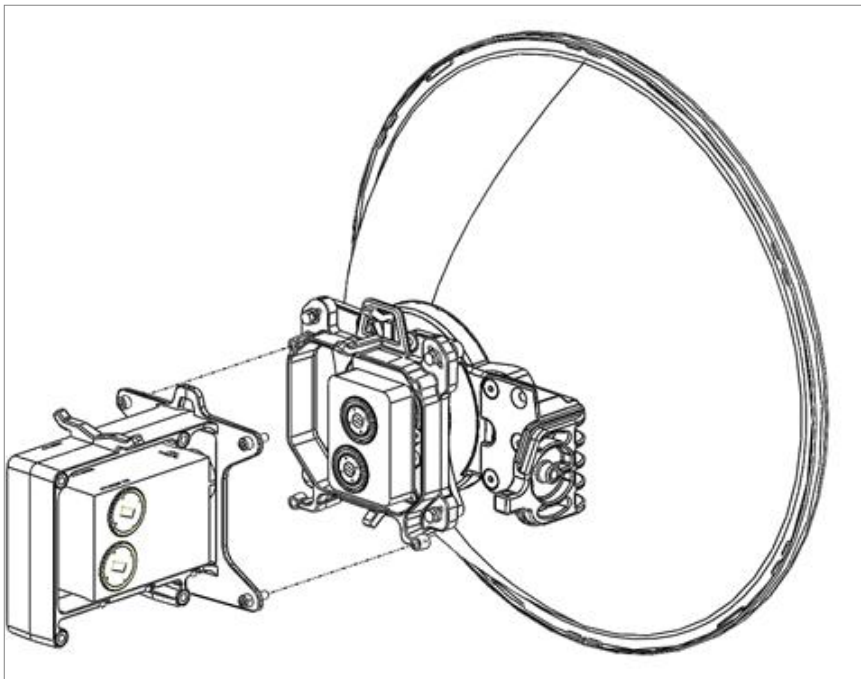

4. Mount and tighten the PTP 850CX radio unit to both sides of the Dual Splitter using the screws assembled on PTP 850CX radio. Pay attention that the O-rings are correctly mounted on the radio ports of the Dual Splitter.

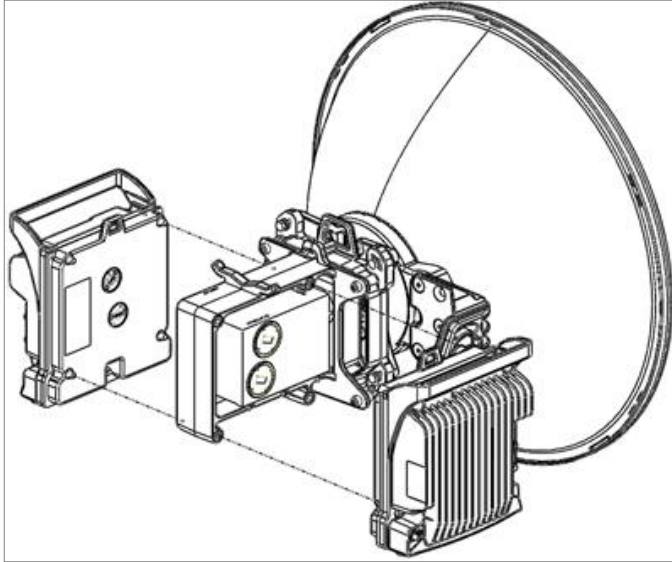

5. Connect an optical cable between the two units for traffic between the two units. It is recommended to use Eth 2 (P3) on each unit for the Traffic Connection.

## 4+0 Layer 1 Link Aggregation, Remote Mount

### List of Items

Item	Description	Quantity	Remarks
1	PTP 850CX RADIO	2	
2	PTP 820C OMT KIT	1	
3	PTP 820C OMT Adaptor	1	6-11 GHz only
4	PTP 820C DUAL SPLITTER KIT	1	
5	FLEXIBLE WG KIT	2	
6	PTP 820C DC POLE MOUNT KIT	1	
7	PTP 820C DC REMOTE MOUNT ADAPTOR KIT	1	6-13 GHz only
8	SFP Transceiver	2	SFP transceiver for connection between units.
9	Optical Cable for transmitting traffic between the units	1	See <a href="#">Table 25</a>



#### Note:

If a non-circular antenna interface is used, add a circular adaptor to this list of items, as described in Step 1.

## Required Tools

- Metric offset hexagon key set
- Metric wrench key set
- Phillips #1, #2 screwdriver

## Procedure

1. If an antenna with a non-circular antenna interface is used, then prior to the installation, follow the antenna manufacturer's instructions to use the circular adaptor. (Remove the existing rectangular transition, swap the O-ring, and install the circular transition instead.)



2. Connect the OMT Kit to the antenna and secure it with four screws. Verify the existence of the O-ring.

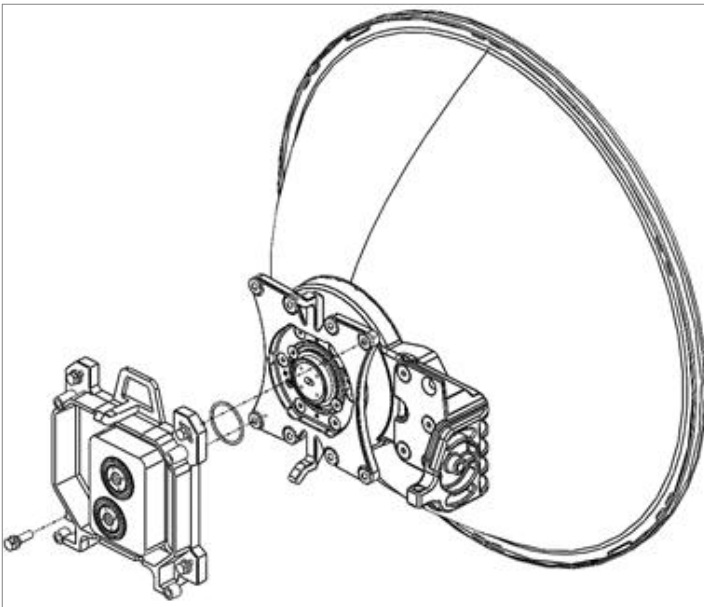

3. For each OMT, mount and tighten the O-ring and the Flexible WG to the PTP 820C OMT ports or the OMT adaptor ports using the four screws supplied with the Flexible WG kit.

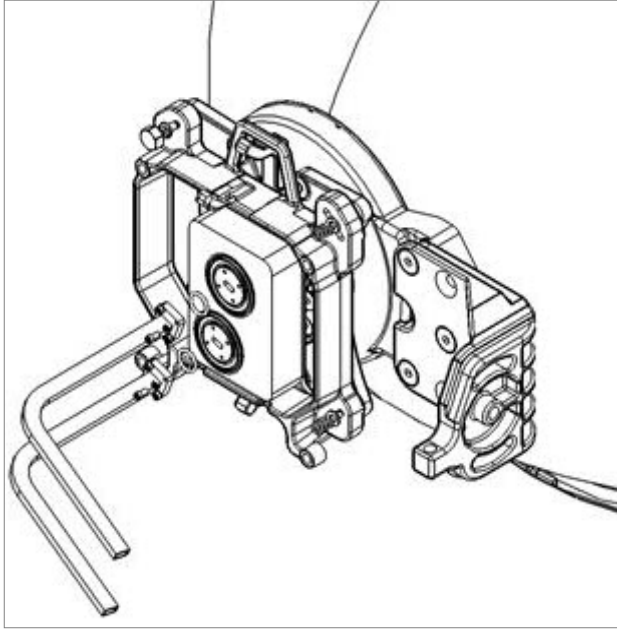

4. For 6-13 GHz only, for each PTP 850CX unit, mount and tighten the PTP 820C Remote Mount Adaptor plate (supplied in PTP 820C Adaptor Remote Mount kit) to the PTP 820C Pole Mount using the four flat screws supplied with the PTP 820C Adaptor Remote Mount kit.

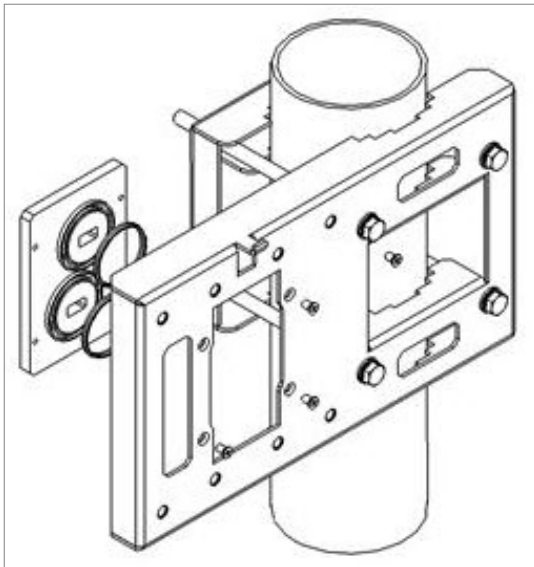

5. Mount and tighten the PTP 820C Dual Splitter to the PTP 820C Pole Mount or Pole Mount Adaptor plate using the four screws and washers that are supplied with the PTP 820C Dual Splitter kit. Pay attention that the O-rings are mounted on the PTP 820C Remote Mount Adaptor.

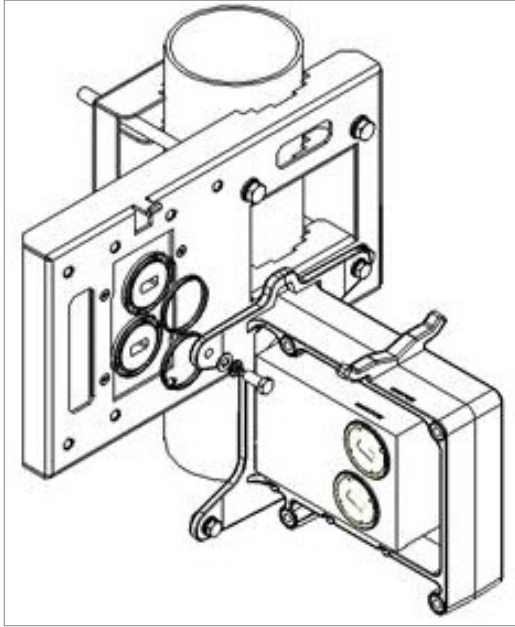

6. Mount and tighten the PTP 850CX radios on each side of the PTP 820C Dual Splitter using the screws assembled on PTP 850CX radio. Pay attention that the O-rings are correctly assembled on the radio port of the Dual Splitter.

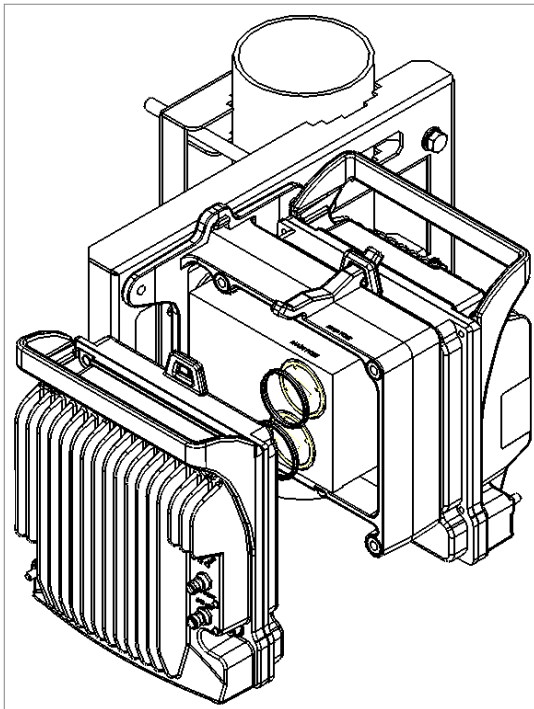

7. Connect both Flexible Waveguides and Sealing Gaskets supplied with each Flexible Waveguide Kit to the PTP 820C Dual Splitter antenna ports. Tighten the screws and washers supplied with the Flexible Waveguide Kit.

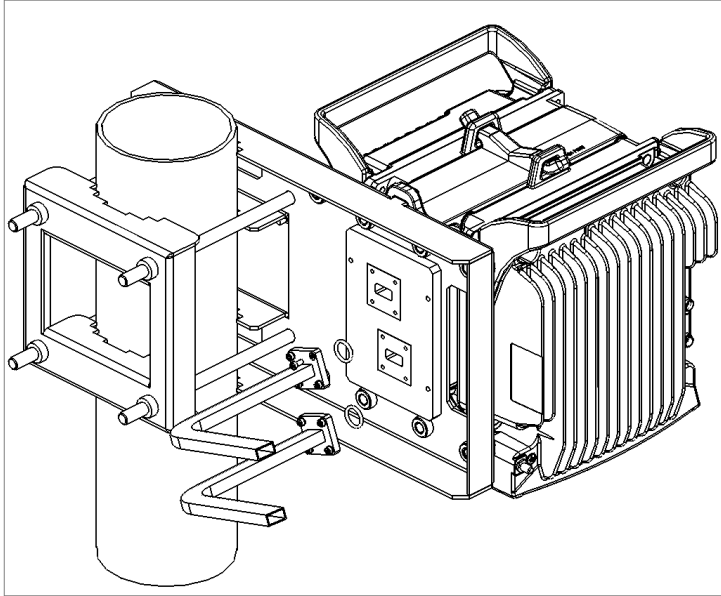

8. Connect an optical cable between the two units for traffic between the two units. It is recommended to use Eth 2 (P3) on each unit for the Traffic Connection.

## 2+2 HSB or 2 x 2+0 Dual Polarization Direct Mount



**Note:**

This procedure can also be used for 2 x 1+1 HSB DP HW ready for 2+2 HSB DP configurations.

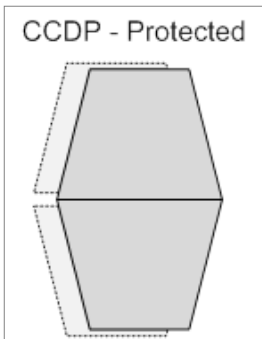

### List of Items

Item	Description	Quantity	Remarks
1	PTP 850CX Radio	2	
2	PTP 820C OMT Kit	1	
3	PTP 820C Dual Coupler Kit	1	

## Required Tools

- Metric offset hexagon key set
- Metric wrench key set

## Procedure

1. Prior to the installation, follow the antenna manufacturer's instructions to use the circular adaptor. (Remove the existing rectangular transition, swap the O-ring, and install the circular transition instead.)



2. Connect the PTP 820C OMT Kit to the antenna and secure it with four screws. Verify existence of the O-ring.

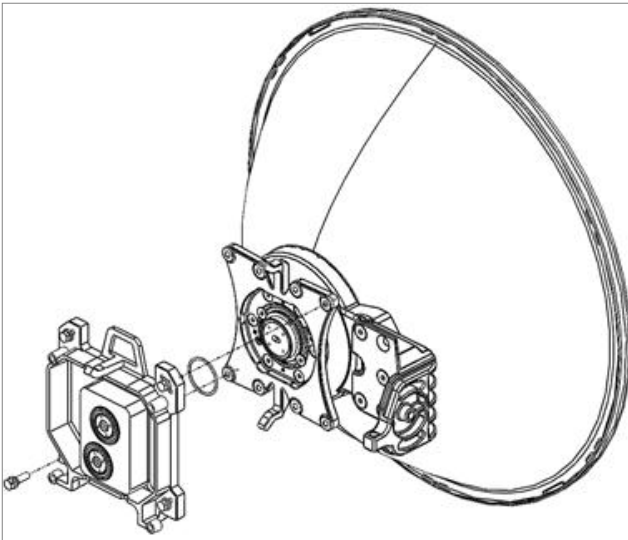

3. Connect the PTP 820C Dual Coupler Kit to the OMT Kit using four M8 screws and washers, and tighten the screws.

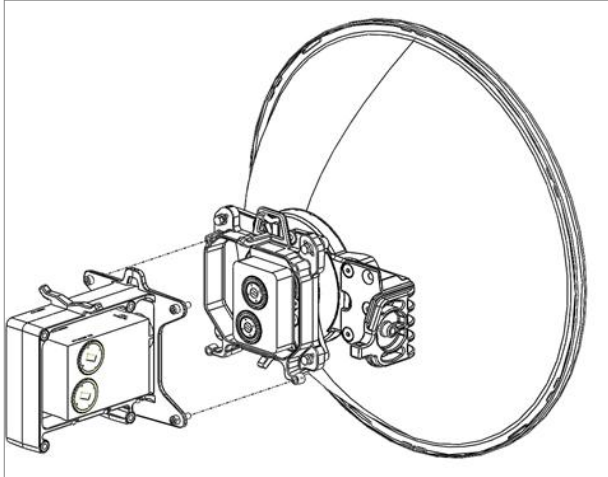

4. Mount and tighten the PTP 850CX radio to both sides of the Dual Coupler Kit using the supplied captive screws and washers. Make sure the O-rings are correctly mounted on the radio ports of the Dual Coupler.

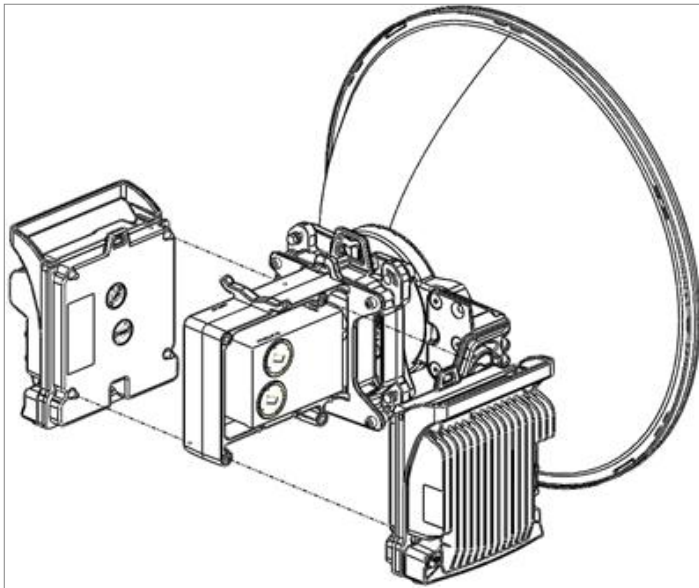

5. Connect the Protection signaling cable between the management ports of both units. For additional instructions on preparing and connecting this cable, refer to [Preparing a Protection Signaling Cable](#).

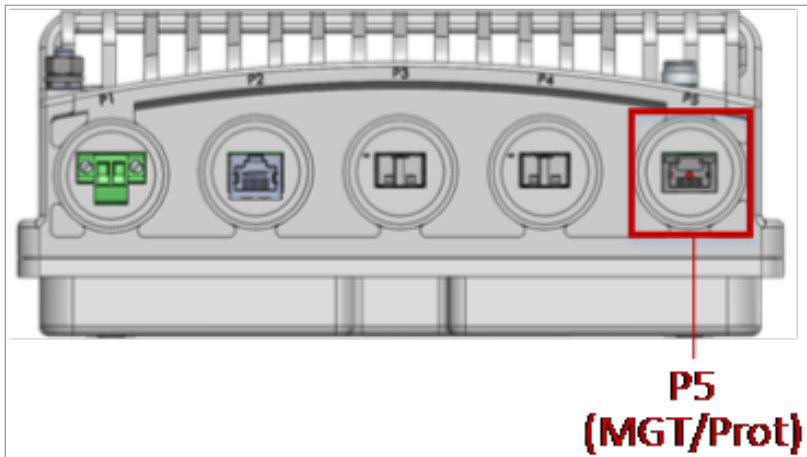

## 2+2 HSB Dual Polarization Remote Mount



**Note:**

This procedure can also be used for 2x 1+1 HSB DP HW ready for 2+2 HSB DP configurations.

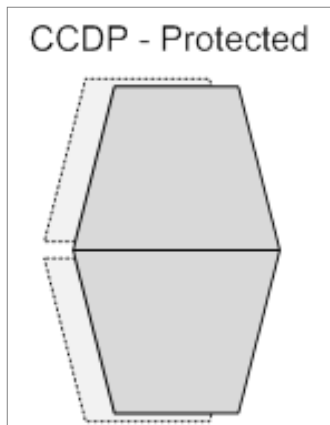

### List of Items

Item	Description	Quantity	Remarks
1	PTP 850CX RADIO	2	
2	PTP 820C OMT KIT	1	
3	PTP 820C DUAL COUPLER KIT	1	
4	FLEXIBLE WG KIT	2	
5	PTP 820C DC POLE MOUNT KIT	1	
6	PTP 820C DC REMOTE MOUNT ADAPTOR KIT	1	13 GHz only
7	CIRC./CIRC. ADAPTOR	1	Per Antenna Vendor.

## Required Tools

- Metric offset hexagon key set
- Metric wrench key set
- Phillips #1, #2 screwdriver

## Common Installation

1. Prior to the installation, follow the antenna manufacturer's instructions to use the circular adaptor. (Remove the existing rectangular transition, swap the O-ring, and install the circular transition instead.)



2. Connect the OMT Kit to the antenna and secure it with four screws. Verify the existence of the O-ring.

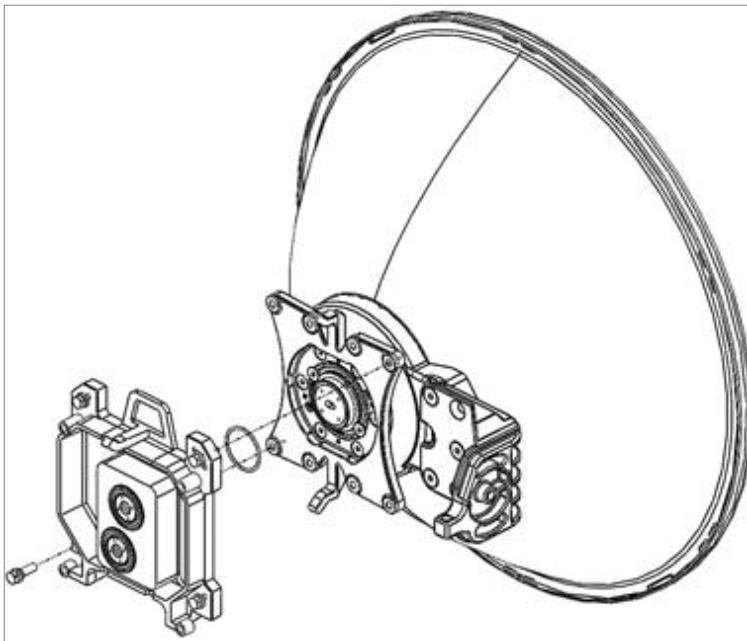

3. Mount and tighten the O-ring and the Flexible WG to the OMT ports using the four screws supplied with the Flexible WG kit.

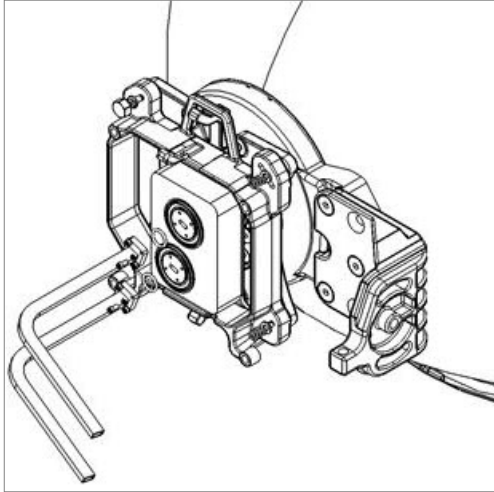

4. Connect the Protection signaling cable between the management ports of both units. For additional instructions on preparing and connecting this cable, refer to [Preparing a Protection Signaling Cable](#).

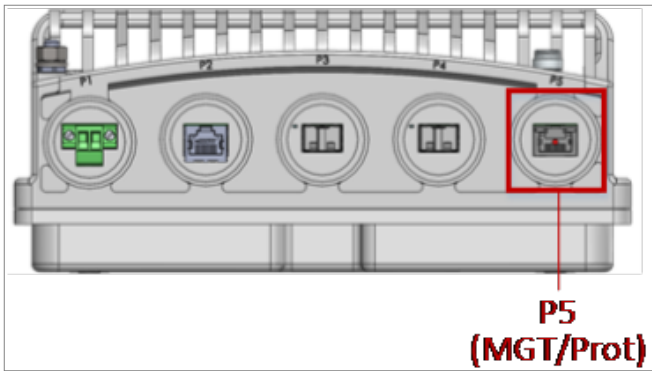

## 13 GHz

1. Mount and tighten the PTP 820C Remote Mount Adaptor plate (supplied in PTP 820C Adaptor Remote Mount kit) to the PTP 820C Pole Mount using the four flat screws supplied with the PTP 820C Adaptor Remote Mount kit.

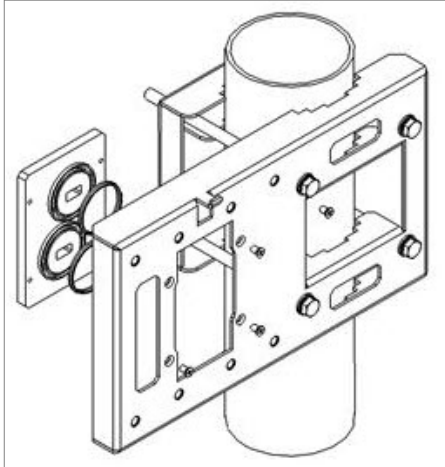

2. Mount and tighten the PTP 820C Dual Coupler to the PTP 820C Pole Mount using the four screws and washers that are supplied with the PTP 820C Dual Coupler kit. Pay attention that the O-rings are mounted on the PTP 820C Remote Mount Adaptor.

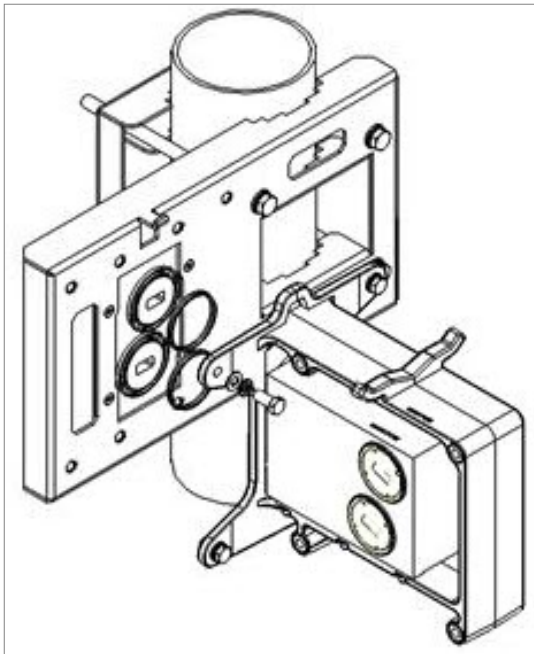

3. Mount and tighten the PTP 850CX radios on each side of the PTP 820C Dual Coupler using the screws assembled on PTP 850CX radio. Pay attention that the O-rings are correctly assembled on the radio port of the PTP 820C Dual coupler.

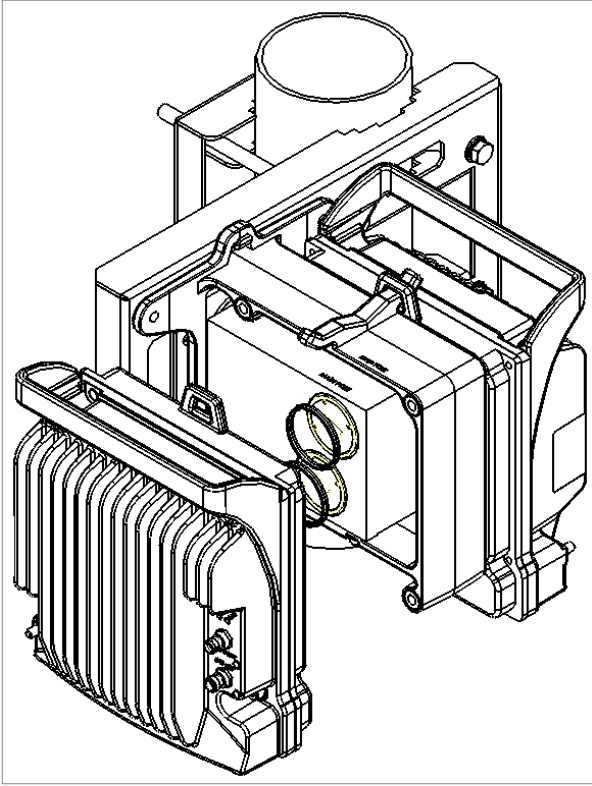

4. Connect both Flexible Waveguides and Sealing Gaskets supplied with each Flexible Waveguide Kit to the PTP 820C Dual Coupler antenna ports. Tighten the screws and washers supplied with the Flexible Waveguide Kit.

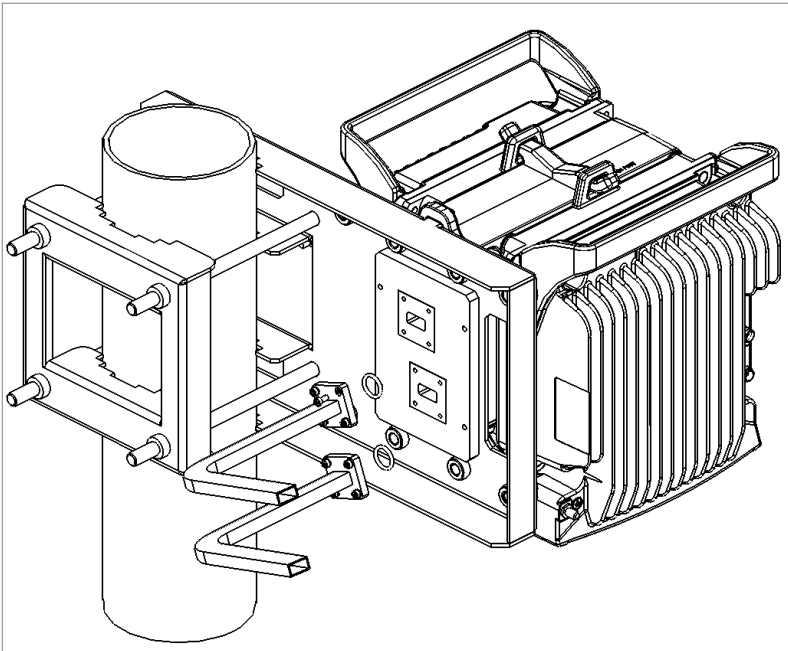

## 15-23 GHz

1. Mount and tighten the PTP 820C Dual Coupler to PTP 820C DC Pole Mount using the four screws and washers supplied with PTP 820C Dual Coupler kit.

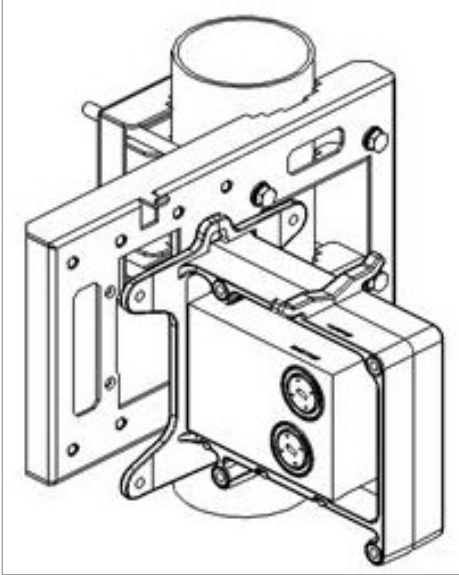

2. Mount and tighten the PTP 850CX radios on each side of the PTP 820C Dual Coupler using the screws assembled on PTP 850CX radio. Pay attention that the O-rings are correctly assembled on the radio port of the PTP 820C Dual coupler.

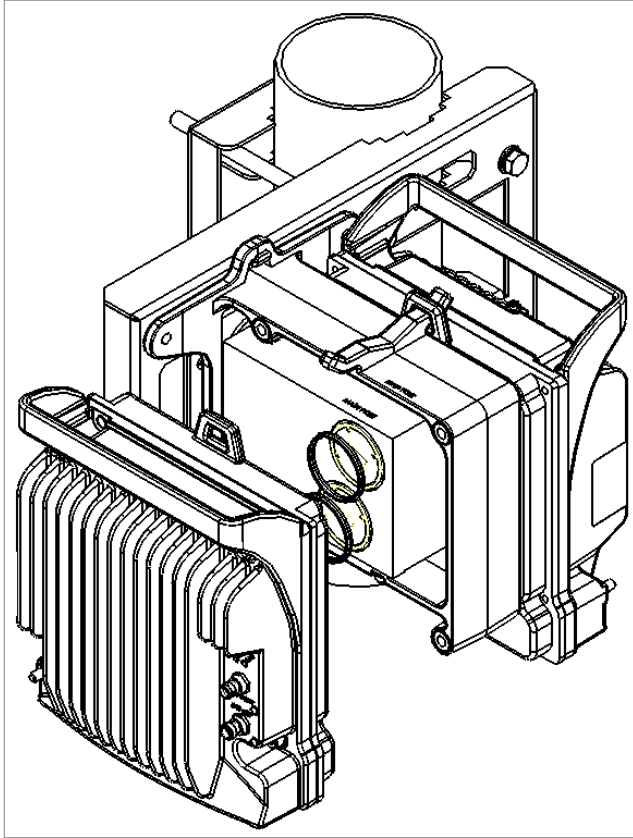

3. Mount the O-ring and the Flexible WG to PTP 820C Dual Coupler ports using the four screws supplied with the Flexible WG kit.

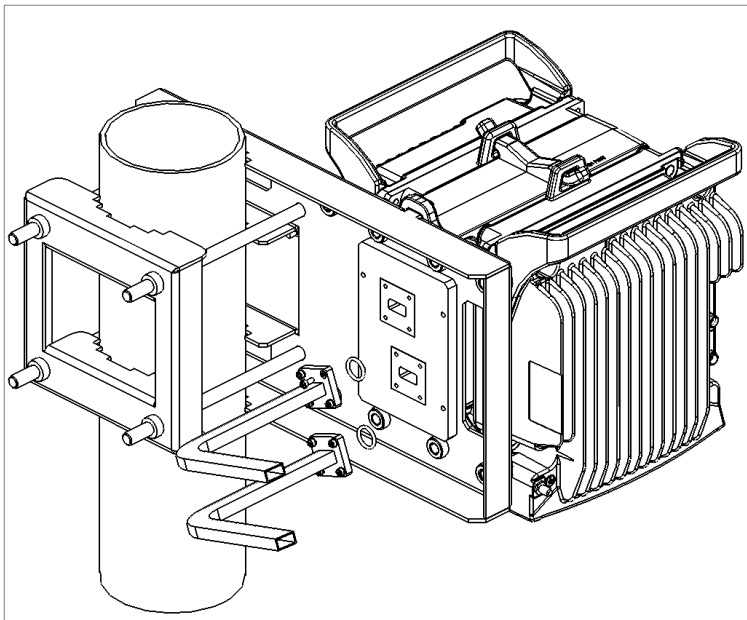

## 2+2 HSB Single Polarization Direct Mount



**Note:**

This procedure can also be used for 2 x 1+1 HSB SP HW ready for 2+2 HSB SP configurations.

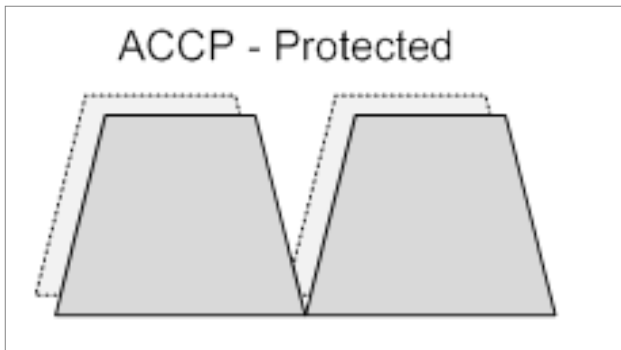

### List of Items

Item	Description	Quantity	Remarks
1	PTP 850CX RADIO	2	
2	PTP 820C SPLITTER KIT	1	
3	DUAL COUPLER KIT	1	

### Required Tools

- Metric offset hexagon key set
- Metric wrench key set
- Phillips #1 screwdriver

### Procedure

1. Adjust the twist on the Splitter Kit. Perform one of the procedures below, according to the required polarization (horizontal or vertical).
  - Horizontal polarization: Locate the holes above and below the letter “H” on the pins and fasten the two screws.

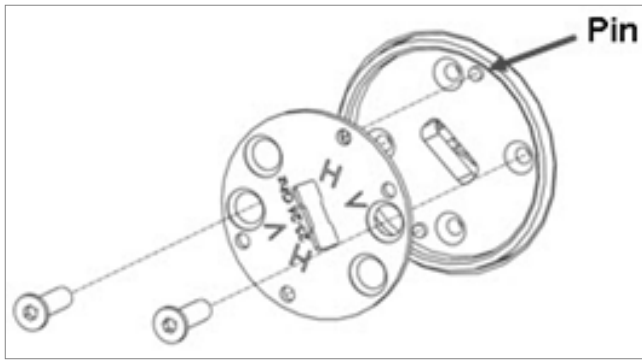

- Vertical polarization: Locate the holes above and below the letter “V” on the pins and fasten the two screws.

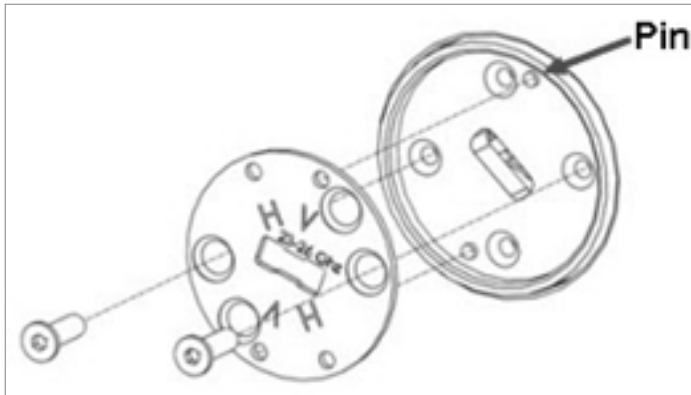

2. Mount the Splitter Kit on the antenna using four M8 screws and washers and tighten the screws.

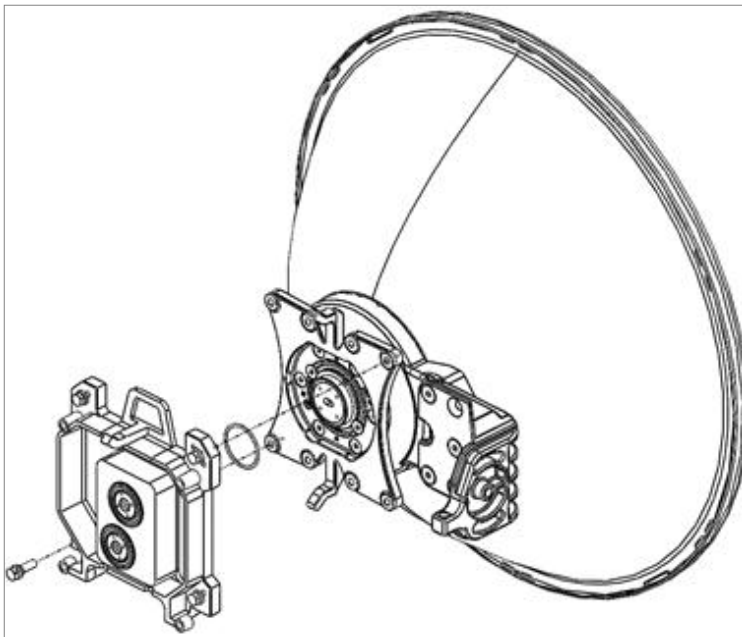

3. Connect the PTP 820C Dual Coupler Kit to the PTP 820C Splitter Kit using four M8 screws and washers and tighten the screws.

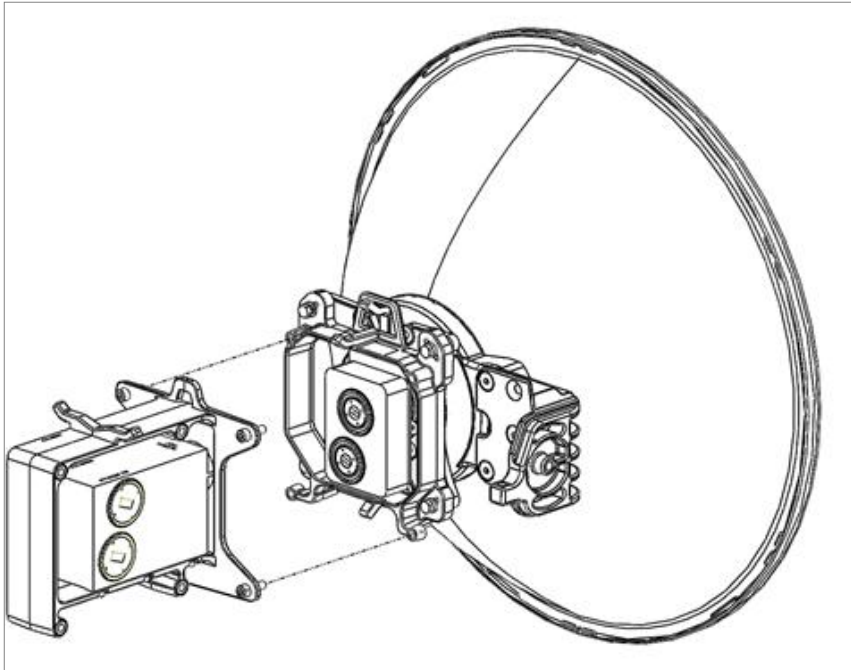

4. Connect the PTP 850CX radio unit to both sides of the Dual Coupler Kit using the supplied captive screws and washers and tighten the screws.

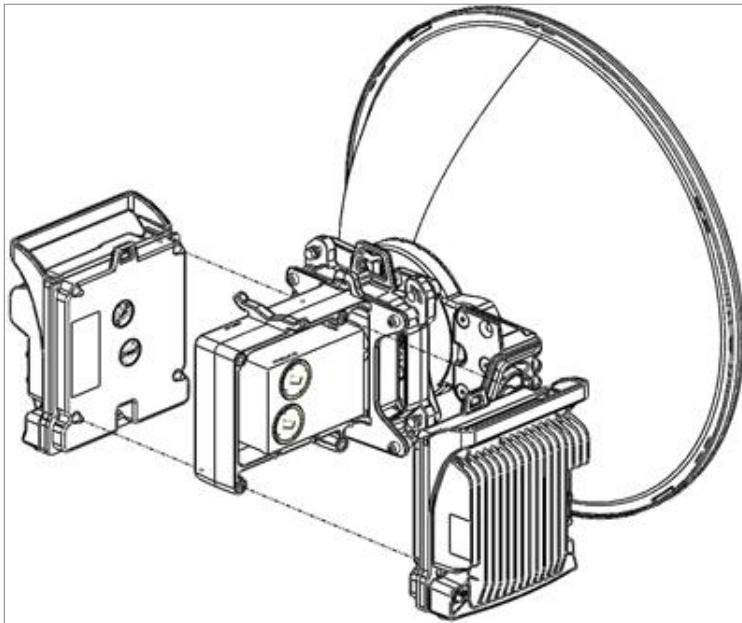

5. Connect the Protection signaling cable between the management ports of both units. For additional instructions on preparing and connecting this cable, refer to [Preparing a Protection Signaling Cable](#).

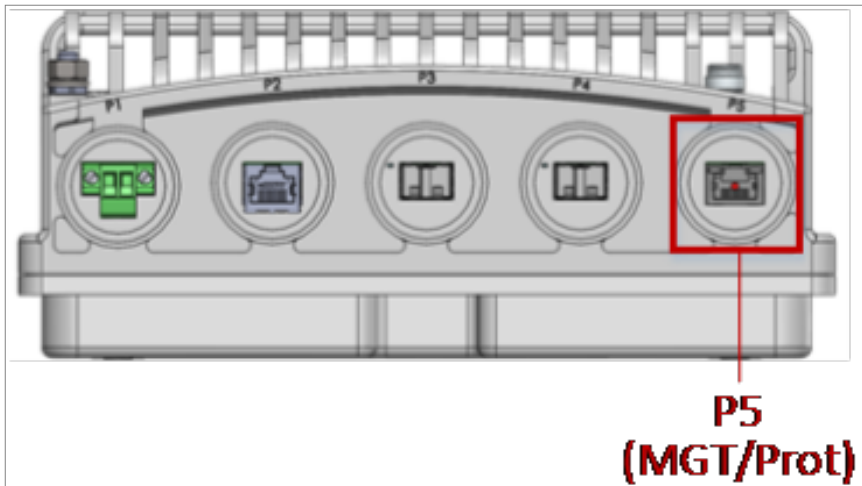

## 2+2 HSB Single Polarization Remote Mount



**Note:**

This procedure can also be used for 2 x 1+1 HSB SP HW ready for 2+2 HSB SP configuration.

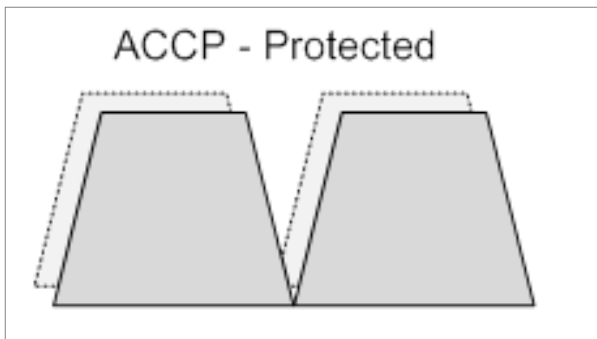

### List of Items

Item	Description	Quantity	Remarks
1	PTP 850CX RADIO	2	
2	PTP 820C SPLITTER KIT	1	
3	PTP 820C DUAL COUPLER KIT	1	
4	FLEXIBLE WG KIT	2	
5	RFU-C POLE MOUNT KIT	1	
6	RFU-C REMOTE MOUNT ADAPTOR	1	13 GHz only

## Required Tools

- Metric offset hexagon key set
- Metric wrench key set
- Phillips #1, #2 screwdriver

## 13 GHz

1. Mount and tighten the RFU-C Remote Mount Adaptor plate (supplied in RFU-C Adaptor Remote Mount kit) to the RFU-C Pole Mount using the four flat screws supplied with the RFU-C Adaptor Remote Mount kit.

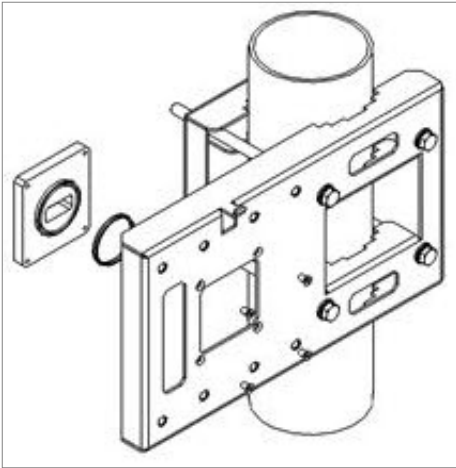

2. Mount and tighten the PTP 820C Splitter to the RFU-C Pole Mount using the four captive screws and washers that are assembled to the PTP 820C Splitter kit.

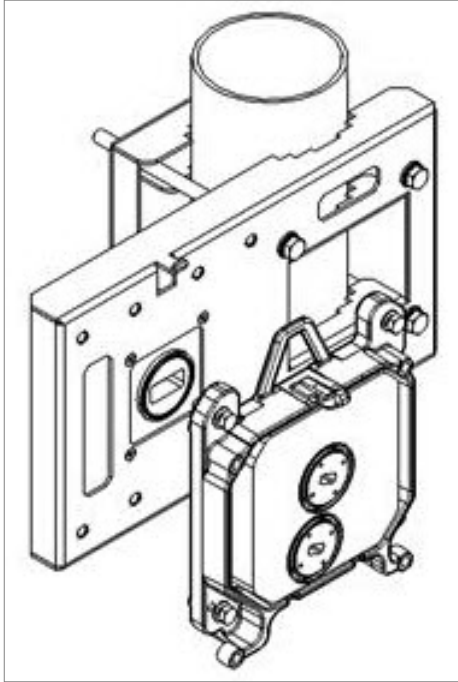

3. Mount and tighten the PTP 820C Dual Coupler to the PTP 820C Splitter using the four captive screws and washers that are supplied with the PTP 820C Dual Coupler kit. Pay attention that the O-rings are mounted on the PTP 820C Splitter.

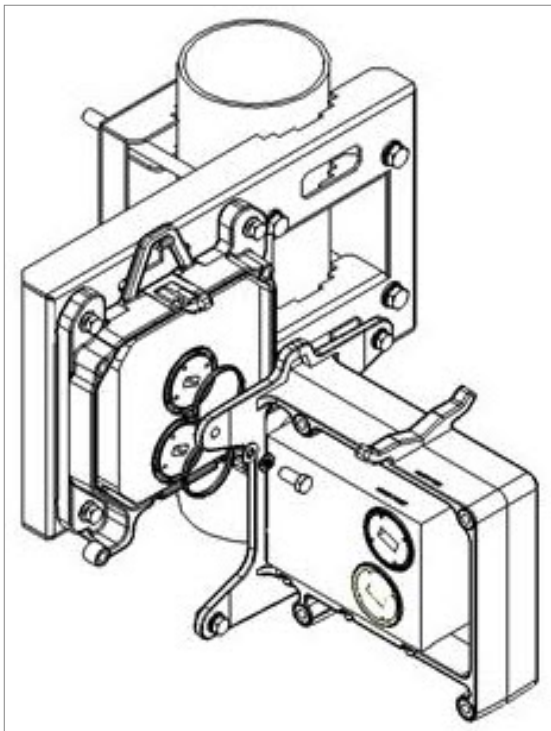

4. Mount and tighten the PTP 850CX Radio to the PTP 820C Dual Coupler using the four screws and washers that are assembled to the PTP 850CX Radio. Pay attention that the O-rings are mounted on the PTP 820C Dual Coupler.

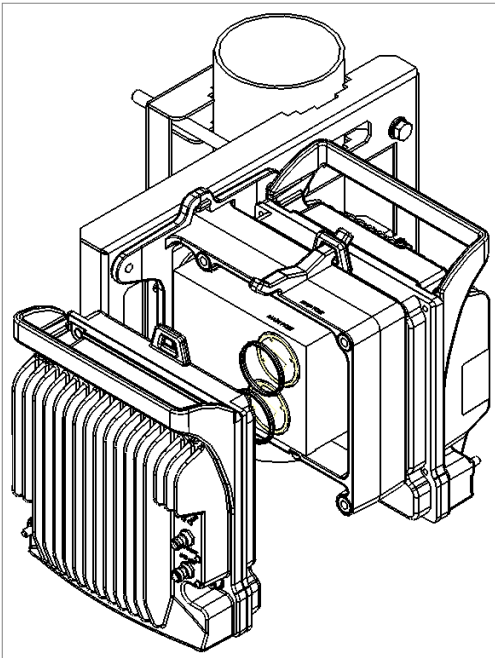

5. Connect the Flexible Waveguide and Sealing Gasket supplied with the Flexible Waveguide Kit to the RFU-C Adaptor plate. Tighten the four screws supplied with the Flexible Waveguide Kit.

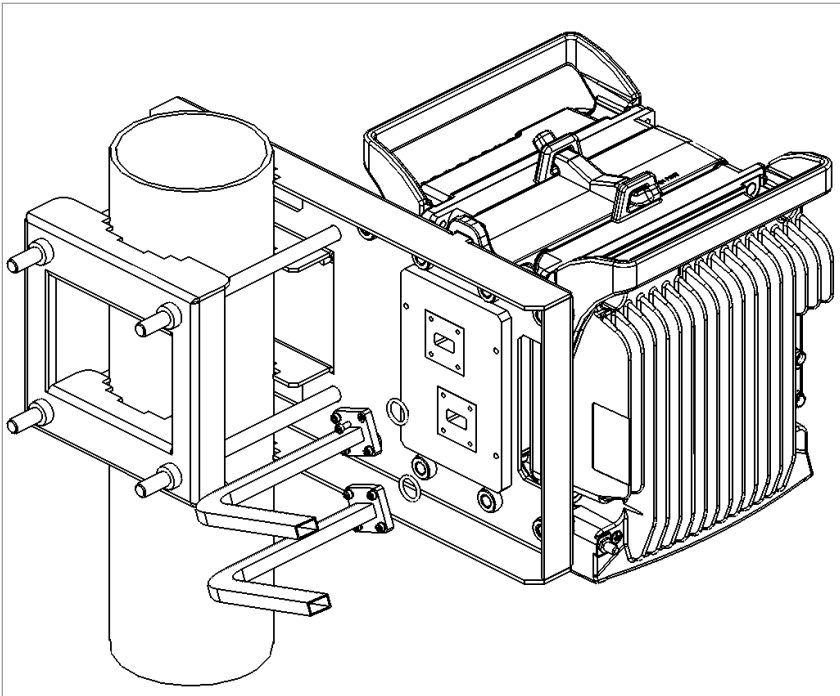

6. Connect the Protection signaling cable between the management ports of both units. For additional instructions on preparing and connecting this cable, refer to [Preparing a Protection Signaling Cable](#).

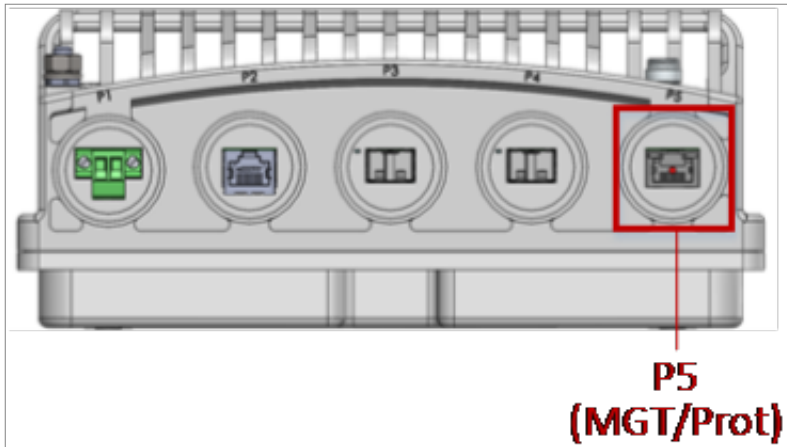

## 15-23 GHz

1. Loosen the two screws, and remove the twist plate from the PTP 820C Splitter.

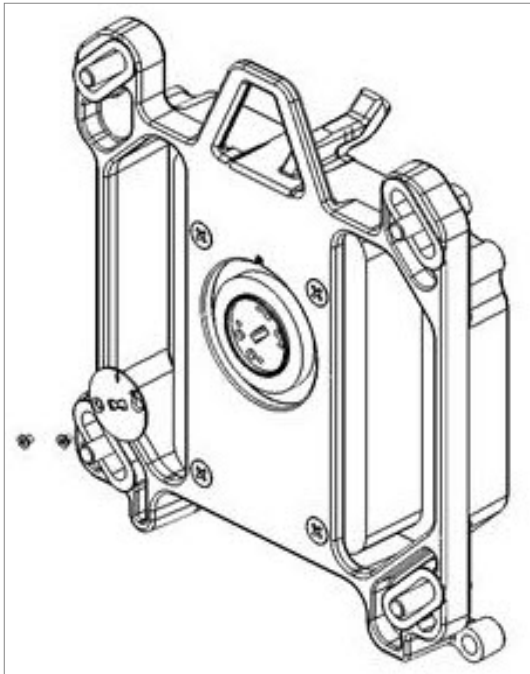

2. Mount and tighten the PTP 820C Splitter to the RFU-C Pole Mount using the four captive screws and washers that are assembled to the PTP 820C Splitter kit.

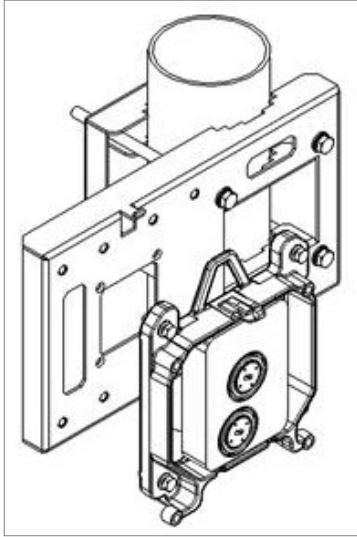

3. Mount and tighten the PTP 820C Dual Coupler to the PTP 820C Splitter using the four captive screws and washers that are supplied with the PTP 820C Dual Coupler kit. Pay attention that the O-rings are mounted on the PTP 820C Splitter.

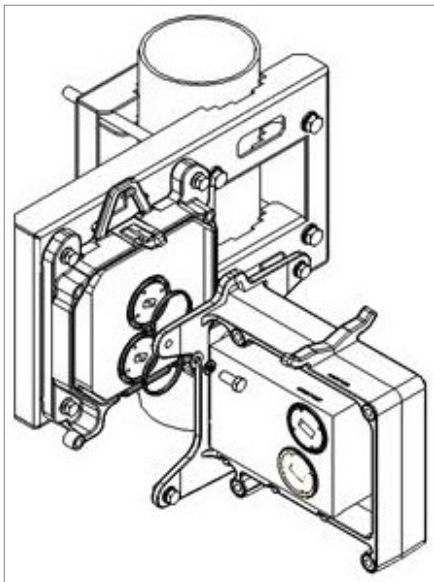

4. Mount and tighten the PTP 850CX Radio to the PTP 820C Dual Coupler using the four screws and washers that are assembled to the PTP 850CX radio. Pay attention that the O-rings are mounted on the PTP 820C Dual Coupler.

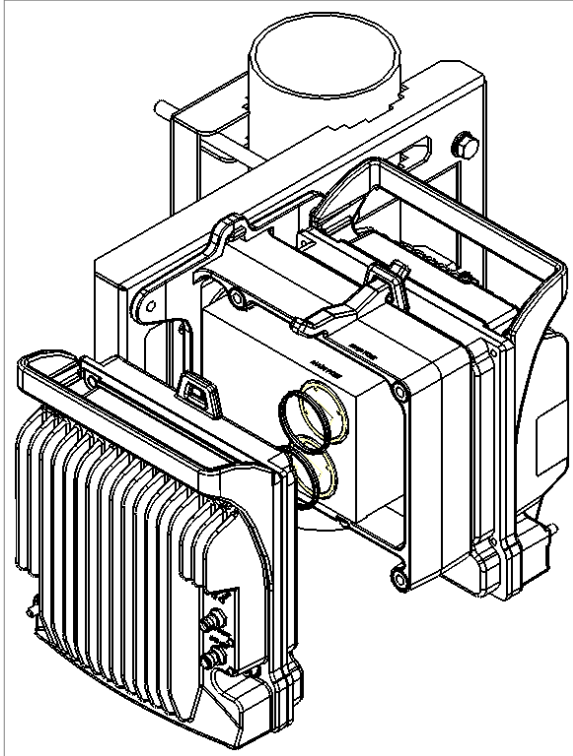

5. Connect the Flexible Waveguide and Sealing Gasket supplied with the Flexible Waveguide Kit to the PTP 820C Dual Coupler antenna port. Tighten the four screws supplied with the Flexible Waveguide kit.

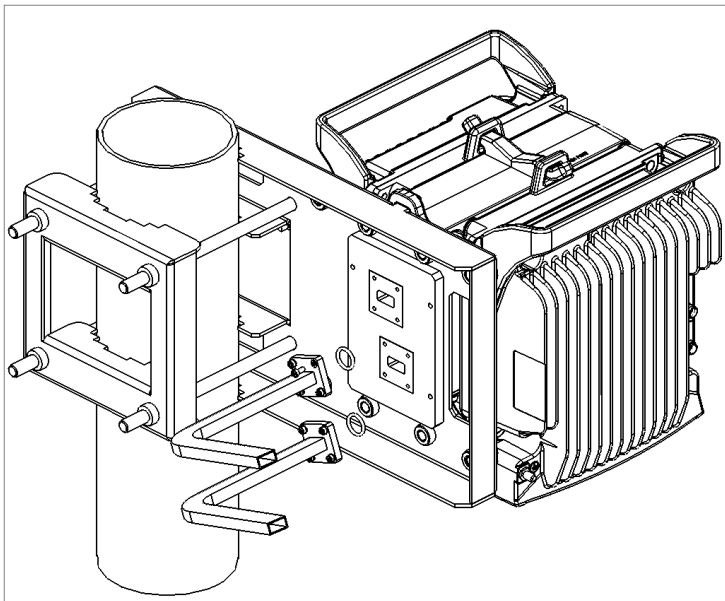

6. Connect the Protection signaling cable between the management ports of both units. For additional instructions on preparing and connecting this cable, refer to [Preparing a Protection Signaling Cable](#).

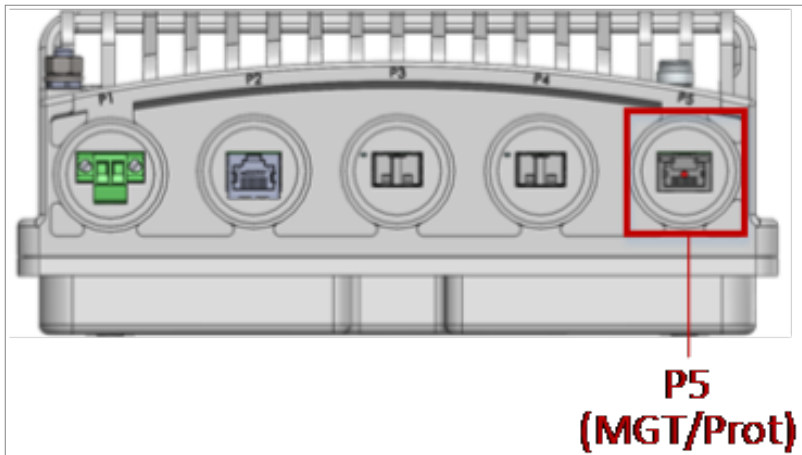

## 2 x 2+0 Dual Polarization Direct Mount



### Note:

This procedure can also be used for 2+0 DP HW ready for 2 x 2+0 DP configurations.

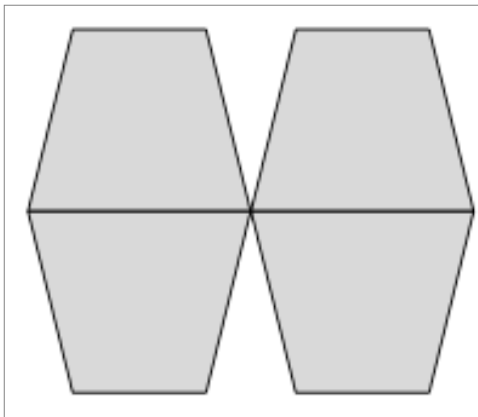

### List of Items

Item	Description	Quantity	Remarks
1	PTP 850CX RADIO	2	
2	PTP 820C OMT KIT	1	
3	PTP 820C DUAL COUPLER or SPLITTER KIT	1	
4	CIRC./CIRC. ADAPTOR	1	Per Antenna Vendor

### Required Tools

- Metric offset hexagon key set
- Metric wrench key set

## Procedure

1. Prior to the installation, follow the antenna manufacturer's instructions to use the circular adaptor. (Remove the existing rectangular transition, swap the O-ring, and install the circular transition instead.)



2. Connect the PTP 820C OMT Kit to the antenna and secure it with four screws. Verify existence of the O-ring.

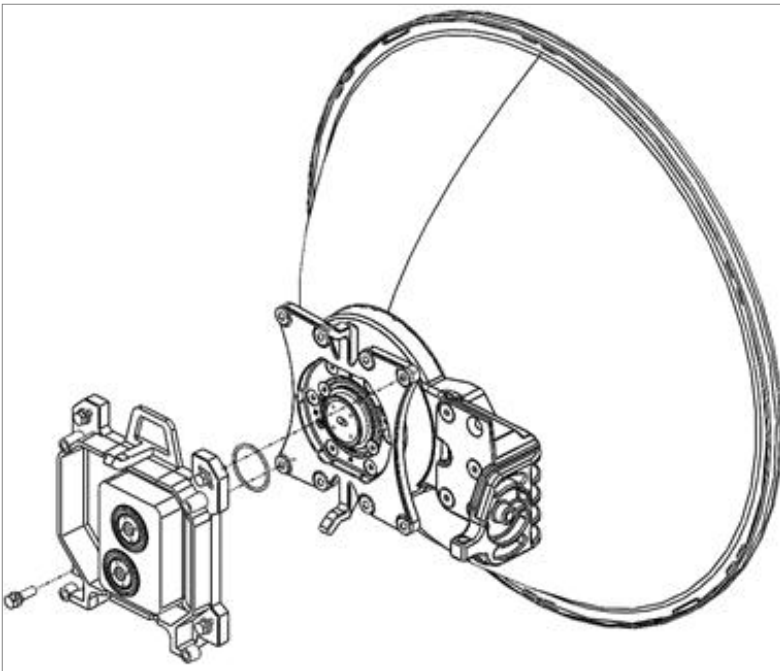

3. Connect the PTP 820C Dual Coupler Kit to the OMT Kit using four M8 screws and washers, and tighten the screws.

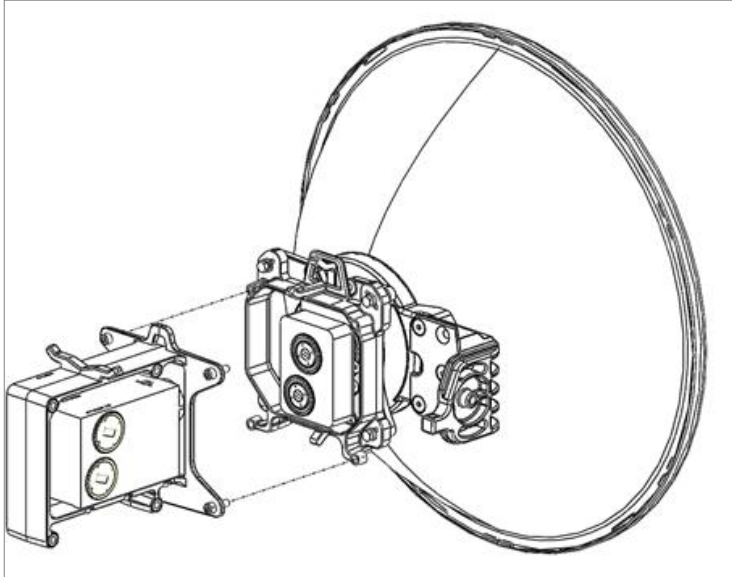

4. Mount and tighten the PTP 850CX radio unit to both sides of the Dual Coupler Kit using the supplied captive screws and washers. Pay attention that the O-rings are correctly mounted on the radio ports of the PTP 820C Dual Coupler.

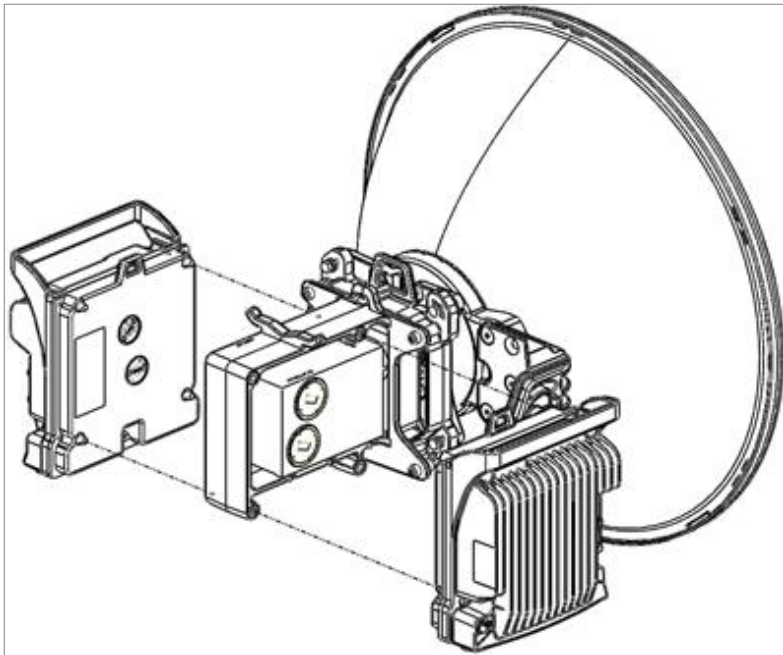

## 2 x 2+0 Dual Polarization Remote Mount



**Note:**

This procedure can also be used for 2 x 1+0 DP HW ready for 2 x 2+0 DP configurations.

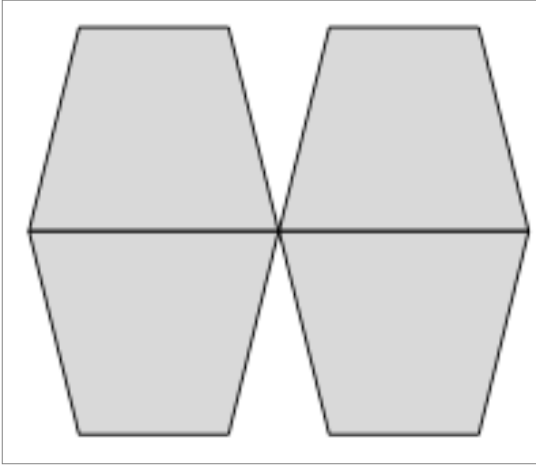

### List of Items

Item	Description	Quantity	Remarks
1	PTP 850CX RADIO	2	
2	PTP 820C OMT KIT	1	
3	PTP 820C DUAL COUPLER OR DUAL SPLITTER KIT	1	
4	FLEXIBLE WG KIT	2	
5	PTP 820C DC POLE MOUNT KIT	1	
6	PTP 820C DC REMOTE MOUNT ADAPTOR KIT	1	13 GHz only
7	CIRC./CIRC. ADAPTOR	1	Per Antenna Vendor

### Required Tools

- Metric offset hexagon key set
- Metric wrench key set
- Phillips #1, #2 screwdriver

### Procedure

1. Prior to the installation, follow the antenna manufacturer's instructions to use the circular adaptor. (Remove the existing rectangular transition, swap the O-ring, and install the circular transition instead.)



2. Connect the OMT Kit to the antenna and secure it with four screws. Verify the existence of the O-ring.

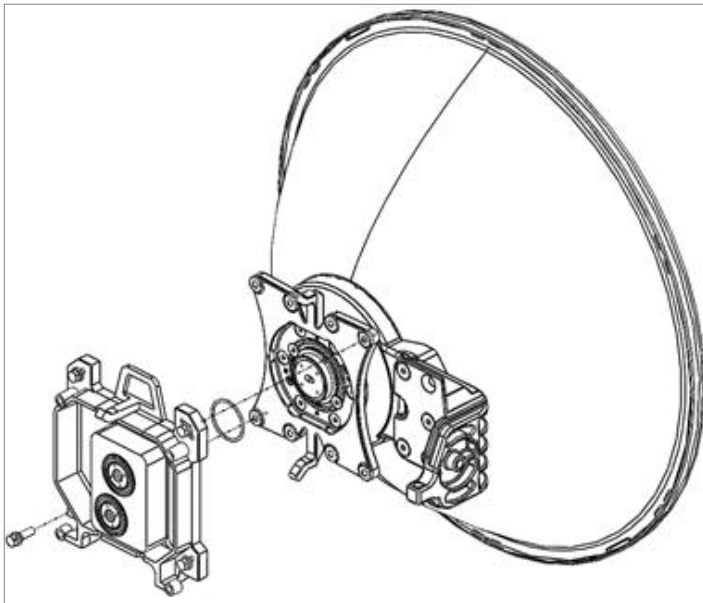

3. Mount and tighten the O-ring and the Flexible WG to PTP 820C OMT ports using the four screws supplied with the Flexible WG kit.

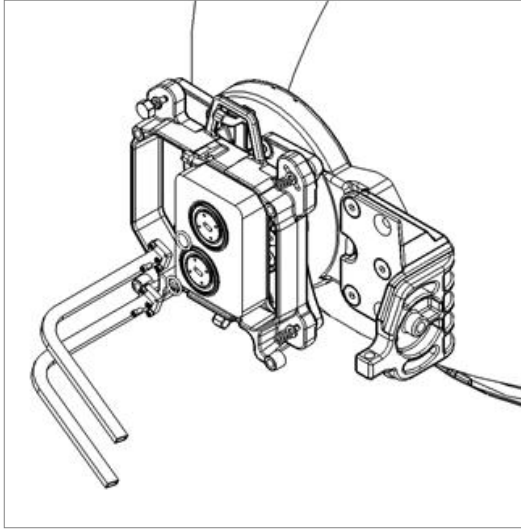

## 13 GHz

1. Mount and tighten the PTP 820-C Remote Mount Adaptor plate (supplied in PTP 820C Adaptor Remote Mount kit) to the PTP 820C Pole Mount using the four flat screws supplied with the PTP 820C Adaptor Remote Mount kit.

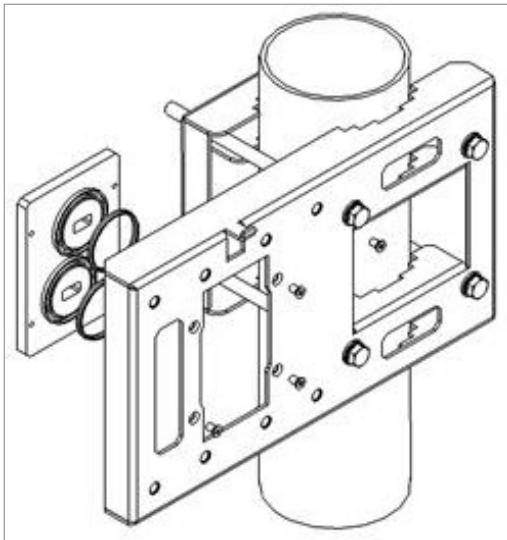

2. Mount and tighten the PTP 820C Dual Coupler to the PTP 820C Pole Mount using the four screws and washers that are supplied with the PTP 820C Dual Coupler kit. Pay attention that the O-rings are mounted on the PTP 820C Remote Mount Adaptor.

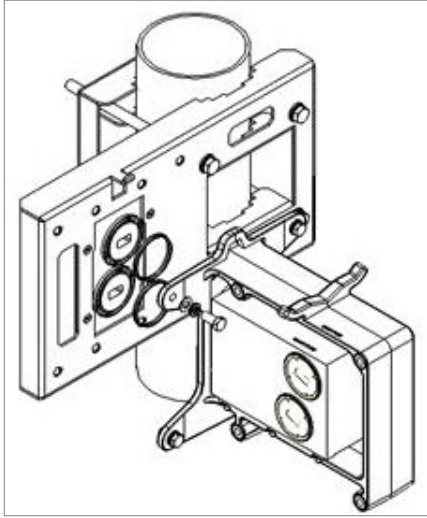

3. Mount and tighten the PTP 850CX radios on each side of the PTP 820C Dual Coupler using the screws assembled on PTP 850CX radio. Make sure that the O-rings are correctly assembled on the radio port of the PTP 820C Dual Coupler.

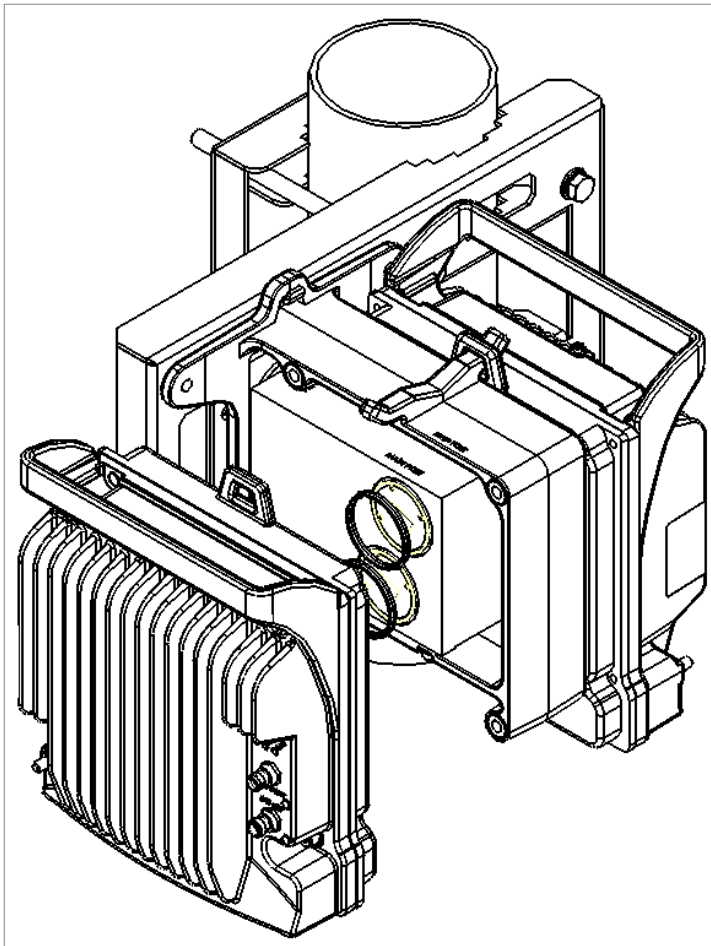

4. Connect both Flexible Waveguides and Sealing Gaskets supplied with each Flexible Waveguide Kit to the PTP 820C Dual Coupler antenna ports. Tighten the screws and washers supplied with the Flexible Waveguide Kit.

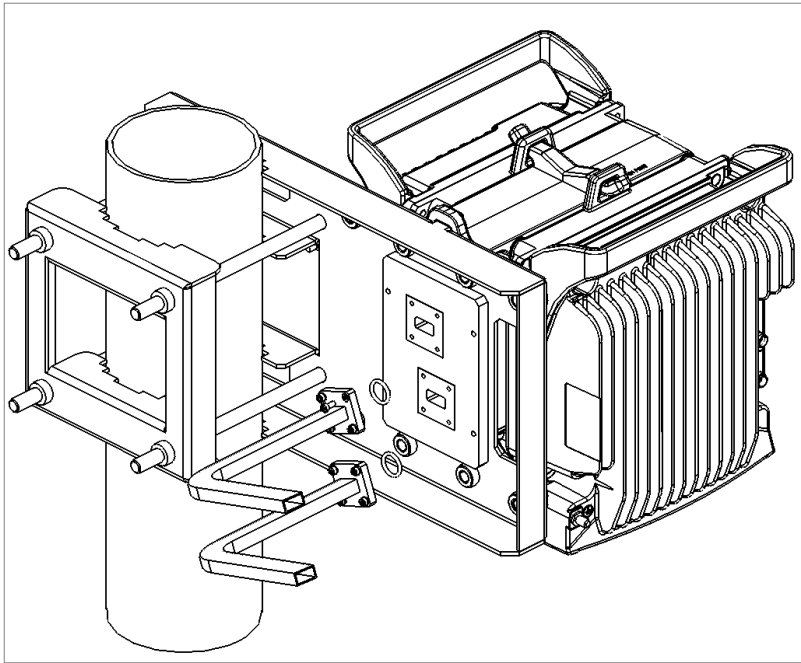

## 15-23 GHz

1. Mount and tighten the PTP 820C Dual Coupler to PTP 820C DC Pole Mount using the four screws and washers supplied with PTP 820C Dual Coupler kit.

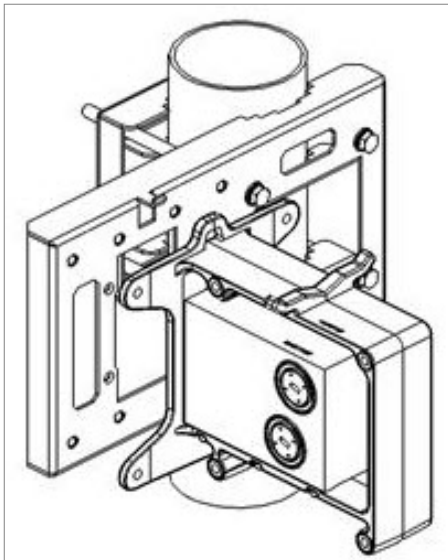

2. Mount and tighten the PTP 850CX radios on each side of the PTP 820C Dual Coupler using the screws assembled on PTP 850CX radio. Pay attention that the O-rings are correctly assembled on the

radio port of the PTP 820C Dual Coupler.

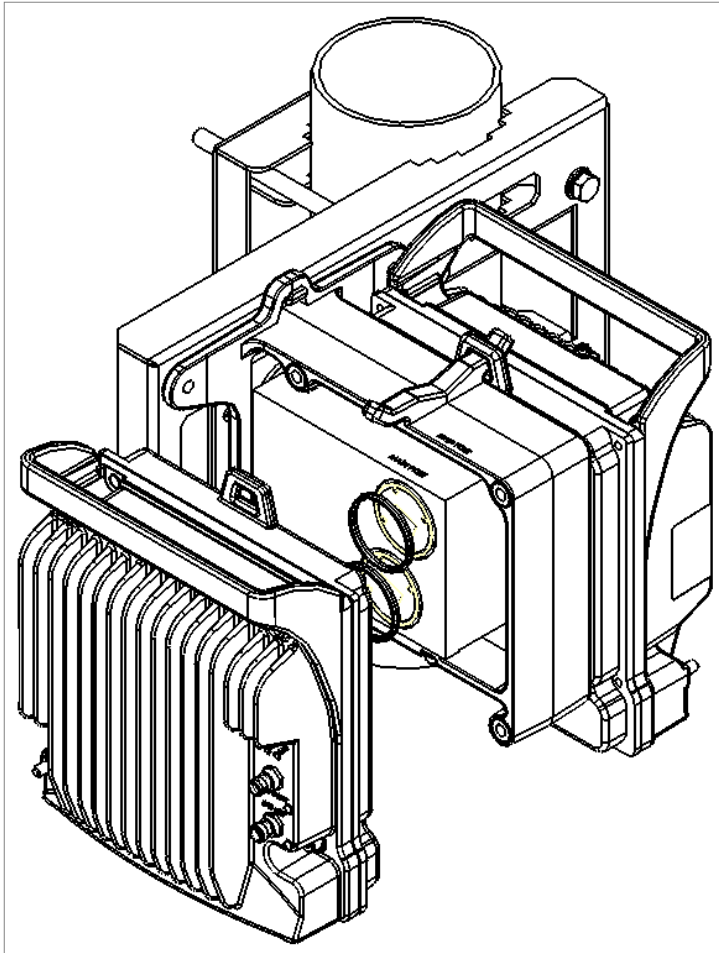

3. Mount the O-ring and the Flexible WG to PTP 820C Dual Coupler ports using the four screws supplied with the Flexible WG kit.

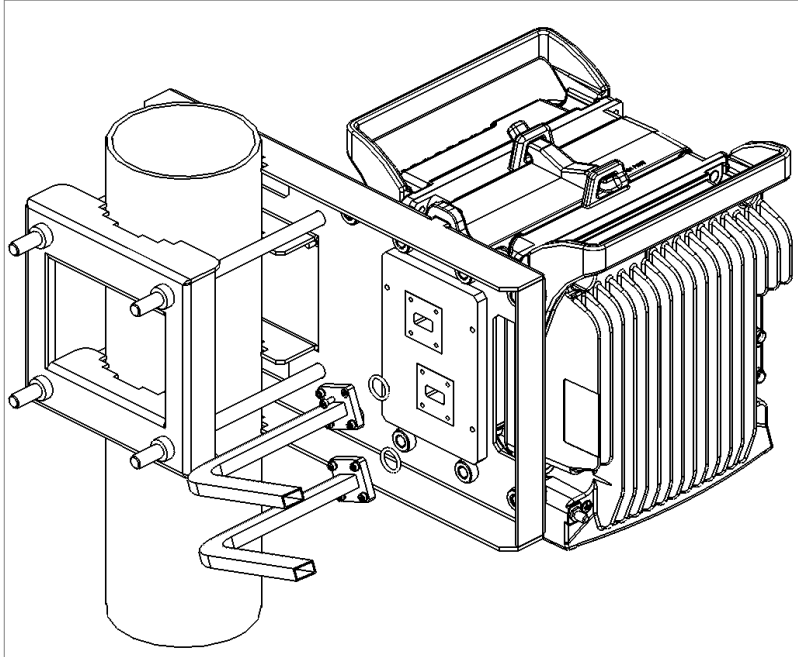

## 2 x 2+0 Single Polarization Direct Mount



**Note:**

This procedure can also be used for 2 x 1+0 SP HW ready for 2 x 2+0 SP configurations.

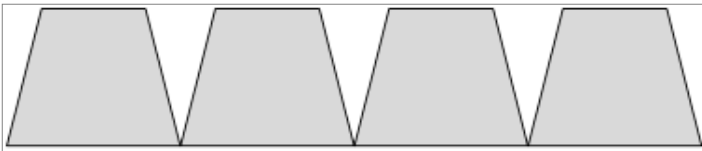

### List of Items

Item	Description	Quantity	Remarks
1	PTP 850CX RADIO	2	
2	PTP 820C Splitter Kit	1	
3	PTP 820C Dual Splitter Kit	1	

### Required Tools

- Metric offset hexagon key set
- Metric wrench key set
- Phillips #1 screwdriver

## Procedure

1. Adjust the twist on the PTP 820C Splitter Kit. Perform one of the procedures below according to the required polarization

- Horizontal polarization: Locate the holes above and below the letter “H” on the pins and fasten the two screws.

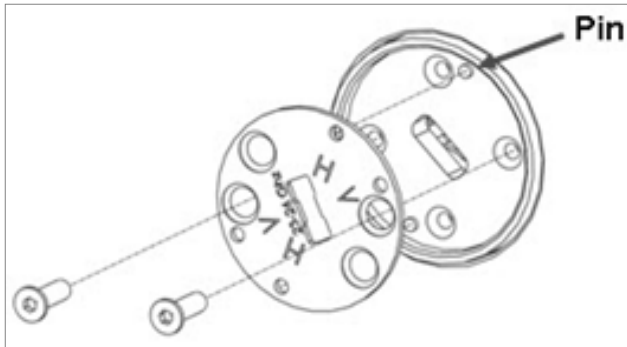

- Vertical polarization: Locate the holes above and below the letter “V” on the pins and fasten the two screws.

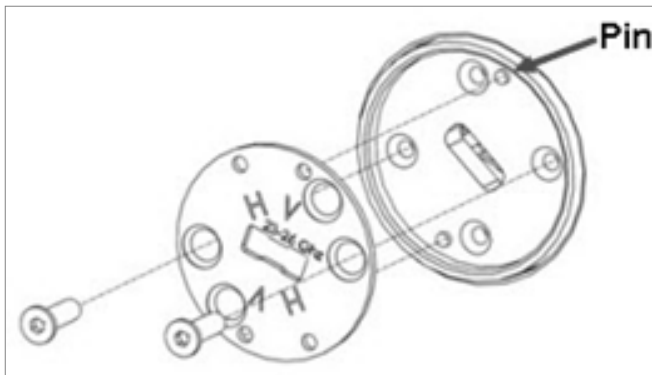

2. Mount the Splitter Kit on the antenna using four M8 screws and washers and tighten the screws.

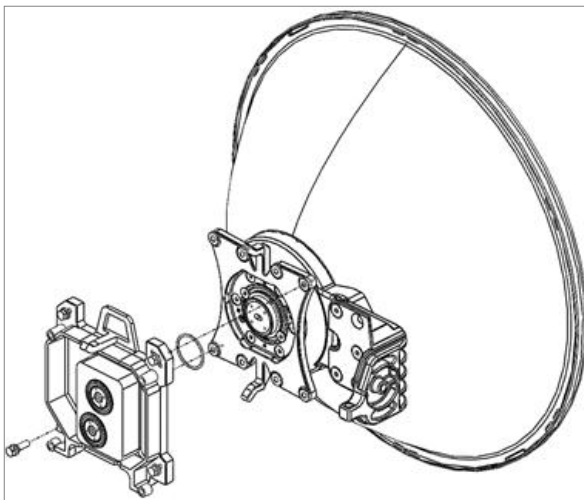

3. Connect the PTP 820C Dual Coupler Kit to the PTP 820C Splitter Kit using four M8 screws and washers and tighten the screws.

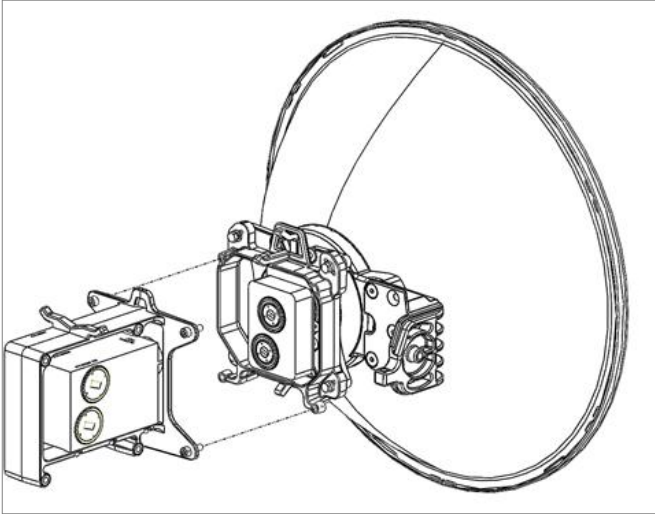

4. Connect the PTP 850CX radio unit to both sides of the Dual Coupler Kit using the supplied captive screws and washers and tighten the screws.

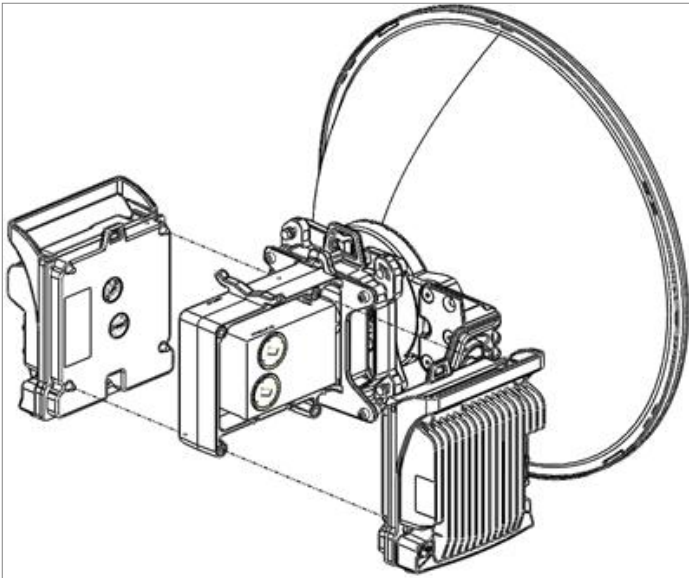

## 4+0 Dual Polarization, 2+2 HSB Single/Dual Polarization Direct Mount

### List of Items

Item	Description	Quantity	Remarks
1	PTP 850CX RADIO	2	1

Item	Description	Quantity	Remarks
2	PTP 820C Dual Coupler/Splitter/Circulator	1	
3	PTP 820C OMT/Splitter Kit	1	

### Required Tools

- Metric offset hexagon key set
- Metric wrench key set

### Procedure

1. Once the OMT/Splitter is mounted to the antenna, connect the PTP 820C Dual Coupler/Splitter kit to the OMT kit using four M8 screws and washers, and tighten the screws.



**Note:**

Verify that the O-ring is properly mounted between the OMT/Splitter ports and the Dual Coupler/Splitter.

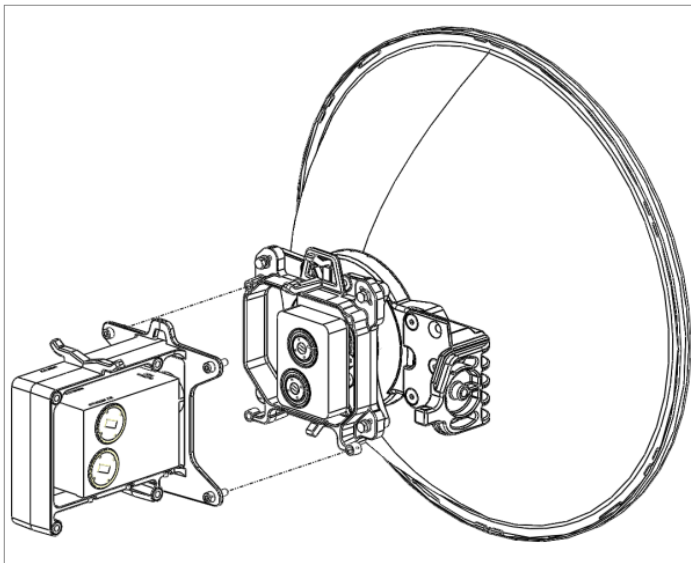

2. Connect the PTP 850CX radios using the four M8 captive screws and washers supplied, and tighten the screws.



**Note:**

Verify that the O-rings are properly mounted between the Dual Coupler/Splitter ports and the radio.

# 4+0 Dual Polarization, 2+2 HSB Dual Polarization Remote Mount

## List of Items

Item	Description	Quantity	Remarks
1	PTP 850CX Radio	2	
2	PTP 820C OMT Kit	1	
3	Flexible Waveguide Kit	2	
4	PTP 820C Dual Coupler/Splitter	1	

## Required Tools

- Metric offset hexagon key set
- Metric wrench key set

## Common Installation

1. Connect the OMT kit to the antenna and secure it with four screws.

**Note:**

Verify that the O-ring is properly mounted between the antenna transition and the OMT.

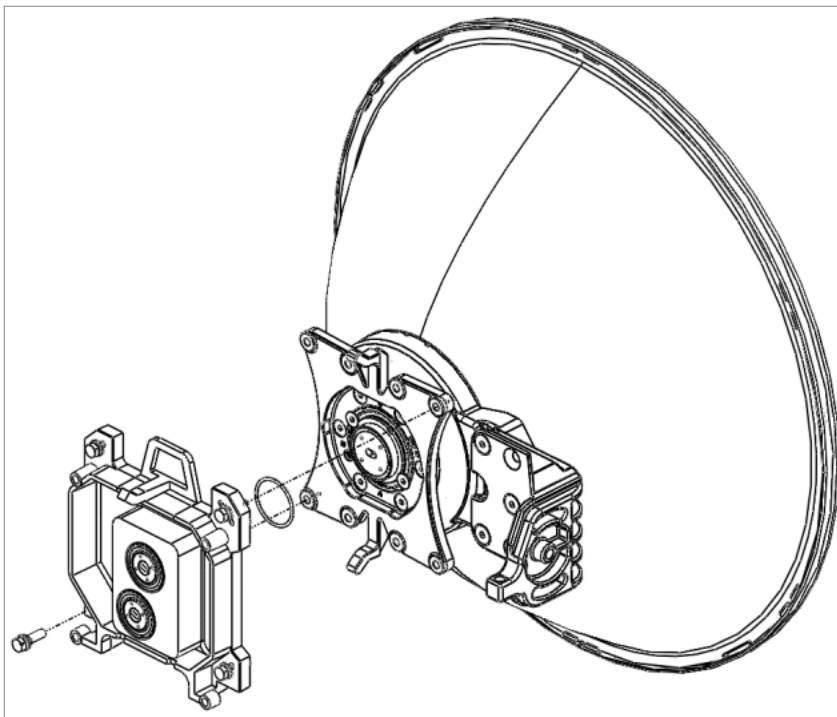

## 13 GHz

1. Mount and tighten the PTP 820-C Remote Mount Adaptor plate (supplied in PTP 820C Adaptor Remote Mount kit) to the PTP 820C Pole Mount using the four flat screws supplied with the PTP 820C Adaptor Remote Mount kit.

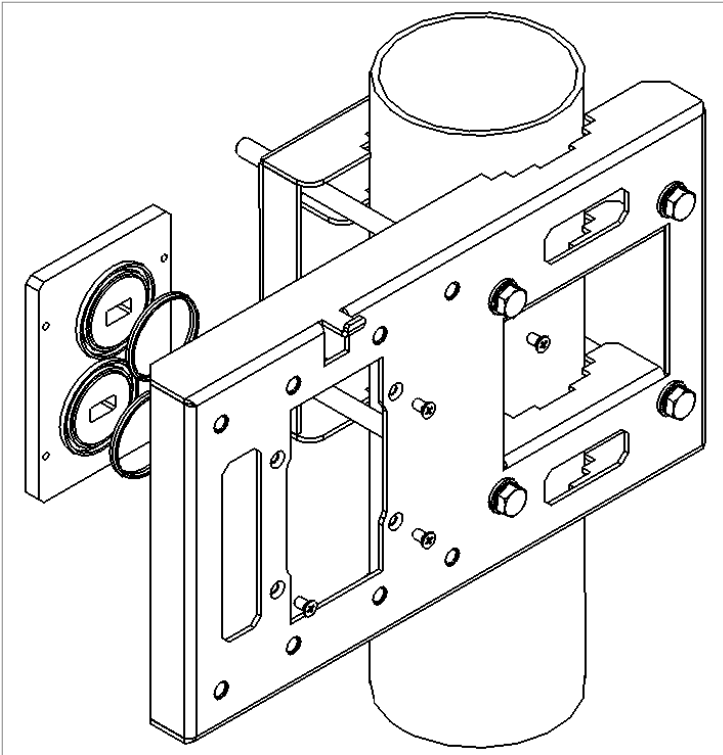

2. Mount and tighten the PTP 820C Dual Coupler to the PTP 820C Pole Mount using the four screws and washers that are supplied with the PTP 820C Dual Coupler kit. Pay attention that the O-rings are mounted on the PTP 820C Remote Mount Adaptor.

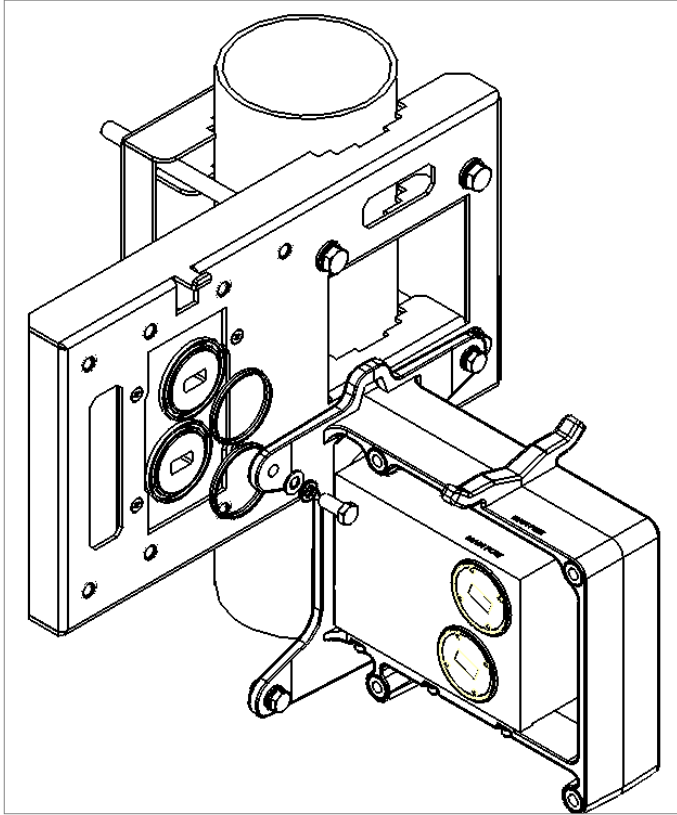

3. Mount and tighten the PTP 850CX radios on each side of the PTP 820C Dual Coupler using the screws assembled on PTP 850CX radio. Make sure that the O-rings are correctly assembled on the radio port of the PTP 820C dual coupler.

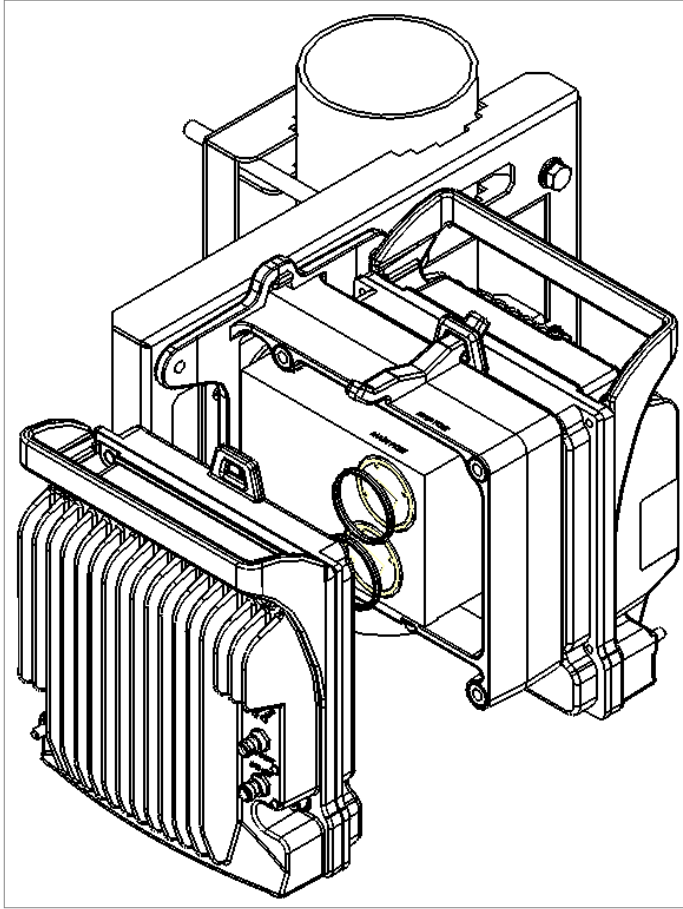

4. Connect both Flexible Waveguides and Sealing Gaskets supplied with each Flexible Waveguide Kit to the PTP 820C Dual Coupler antenna ports. Tighten the screws and washers supplied with the Flexible Waveguide Kit.

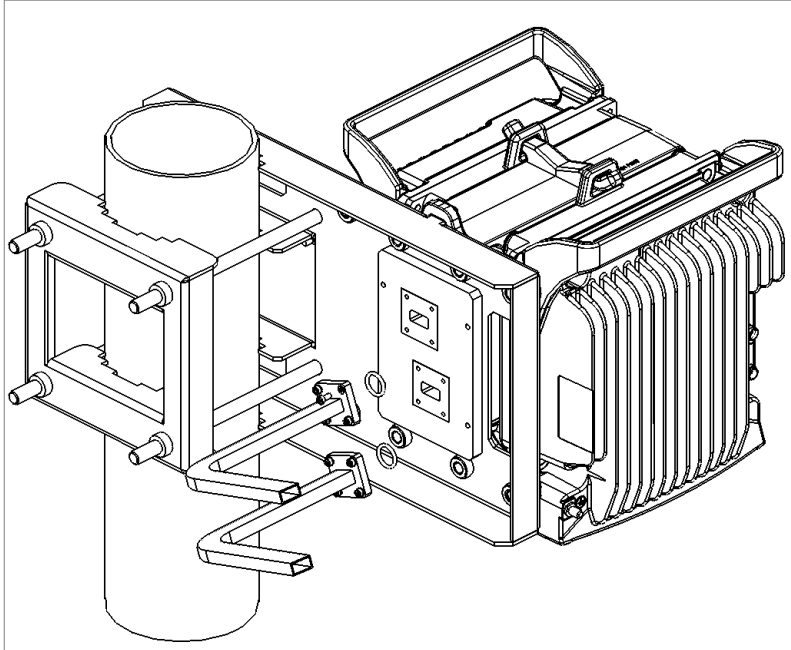

## 15-23 GHz

1. Mount and tighten the PTP 820C Dual Coupler to the PTP 820C DC Pole Mount using the four screws and washers supplied with the PTP 820C Dual Coupler kit.

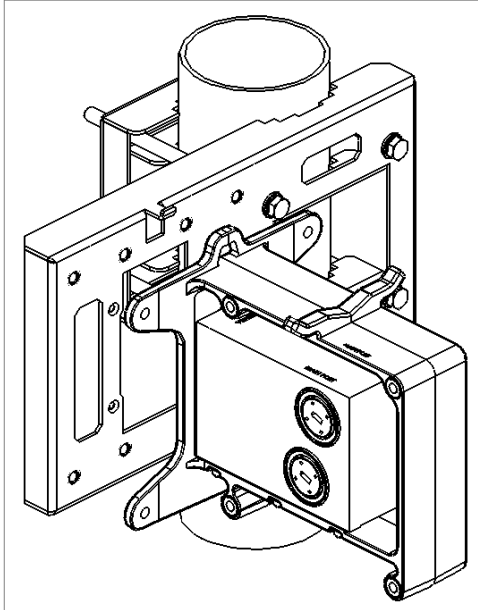

2. Mount and tighten the PTP 850CX radios on each side of the PTP 820C Dual Coupler using the screws assembled on the PTP 850CX unit. Make sure that the O-rings are correctly assembled on the radio port of the PTP 820C Dual Coupler.

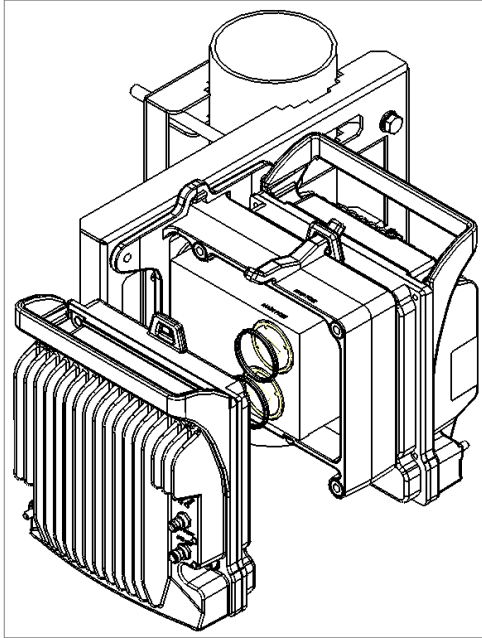

3. Mount the O-ring and the Flexible Waveguides to the PTP 820C Dual Coupler ports using the four screws supplied with the Flexible Waveguide kits.

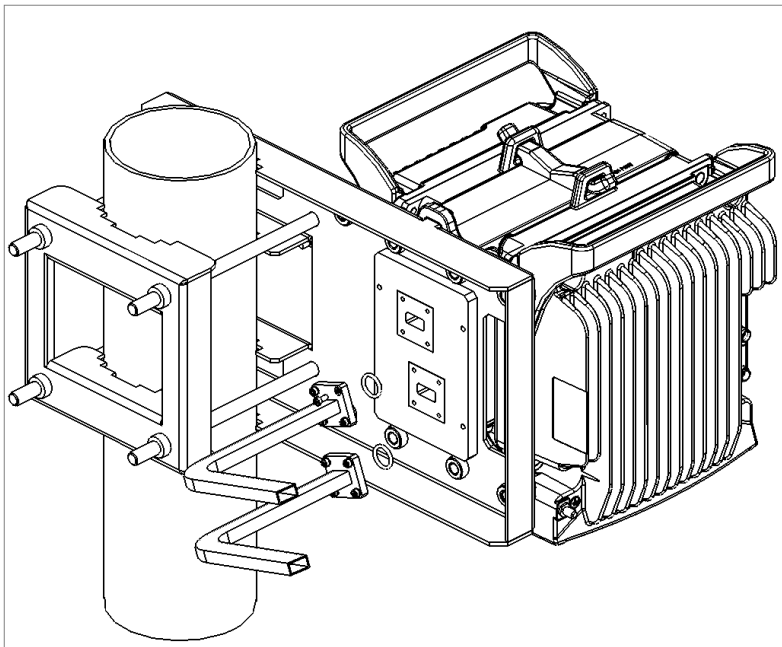

4. Mount and tighten the O-ring and the Flexible Waveguides to the PTP 820C OMT ports using the four screws supplied with the Flexible Waveguide kits.



**Note:**

Verify that the O-rings are correctly mounted between the OMT ports and each Flexible Waveguide.

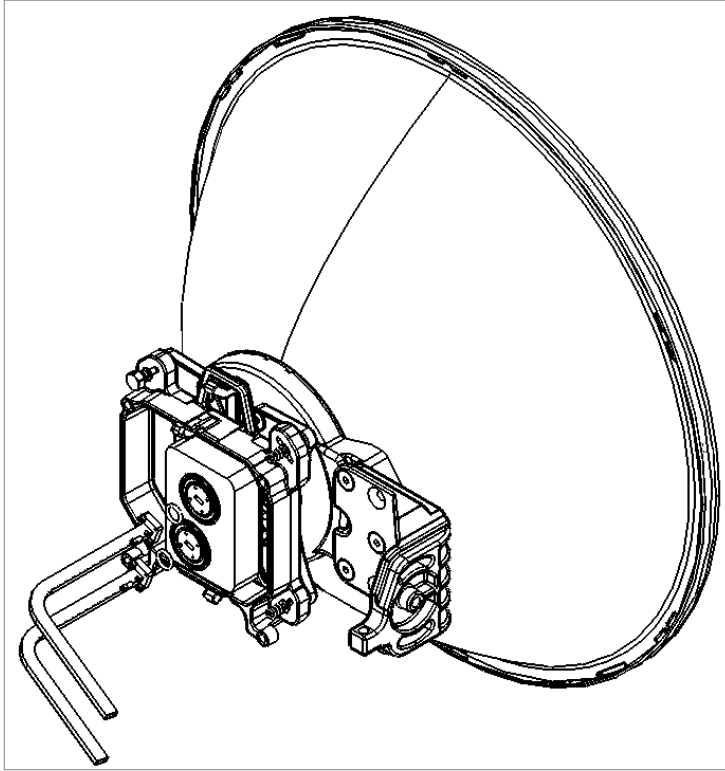

## 2+2 HSB Single Polarization Remote Mount



**Note:**

This procedure can also be used for 1+1HSB SP HW ready for 2+2HSB SP configurations.

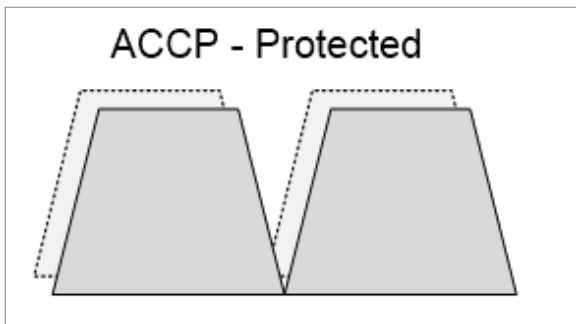

### List of Items

Item	Description	Quantity	Remarks
1	PTP 850CX RADIO	2	
2	PTP 820C SPLITTER KIT	1	
3	PTP 820C DUAL COUPLER KIT	1	

Item	Description	Quantity	Remarks
4	FLEXIBLE WG KIT	2	
5	RFU-C POLE MOUNT KIT	2	

### Required Tools

- Metric offset hexagon key set
- Metric wrench key set
- Phillips #1, #2 screwdriver

## 13 GHz

1. Mount and tighten the RFU-C Remote Mount Adaptor plate (supplied in the RFU-C Adaptor Remote Mount kit) to the RFU-C Pole Mount using the four flat screws supplied with the RFU-C Adaptor Remote Mount kit.

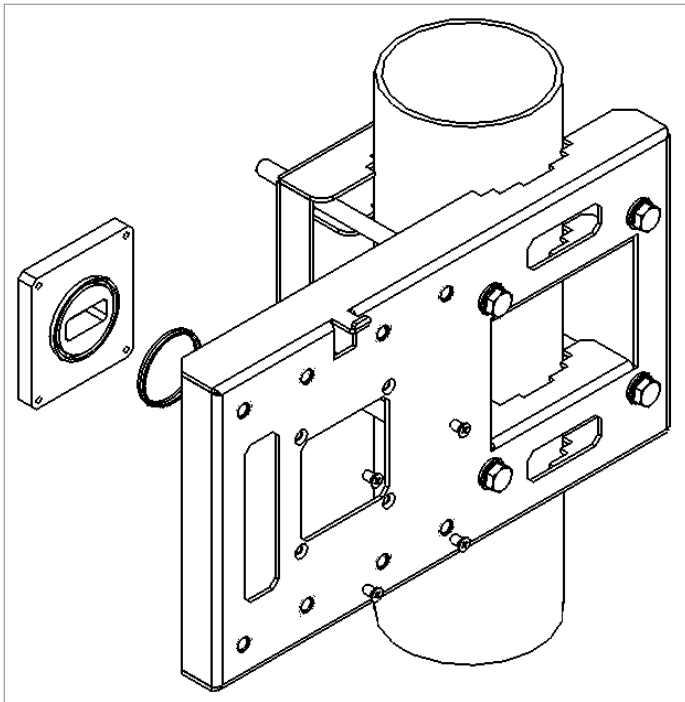

2. Mount and tighten the PTP 820C Splitter to the RFU-C Pole Mount using the four captive screws and washers that are assembled to the PTP 820C Splitter kit.

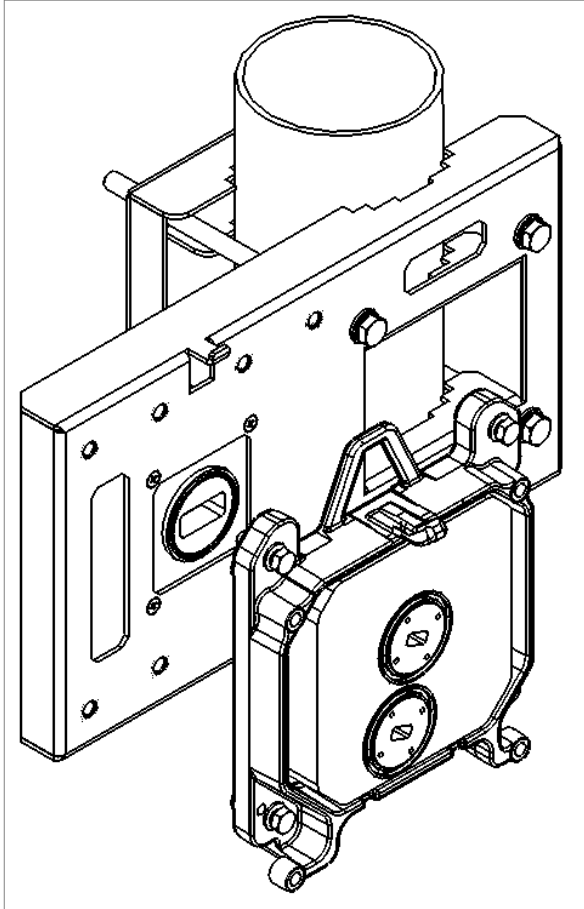

3. Mount and tighten the PTP 820C Dual Coupler to the PTP 820C Splitter using the four captive screws and washers that are supplied with the PTP 820C Dual Coupler kit. Make sure that the O-rings are mounted on the PTP 820C Splitter.

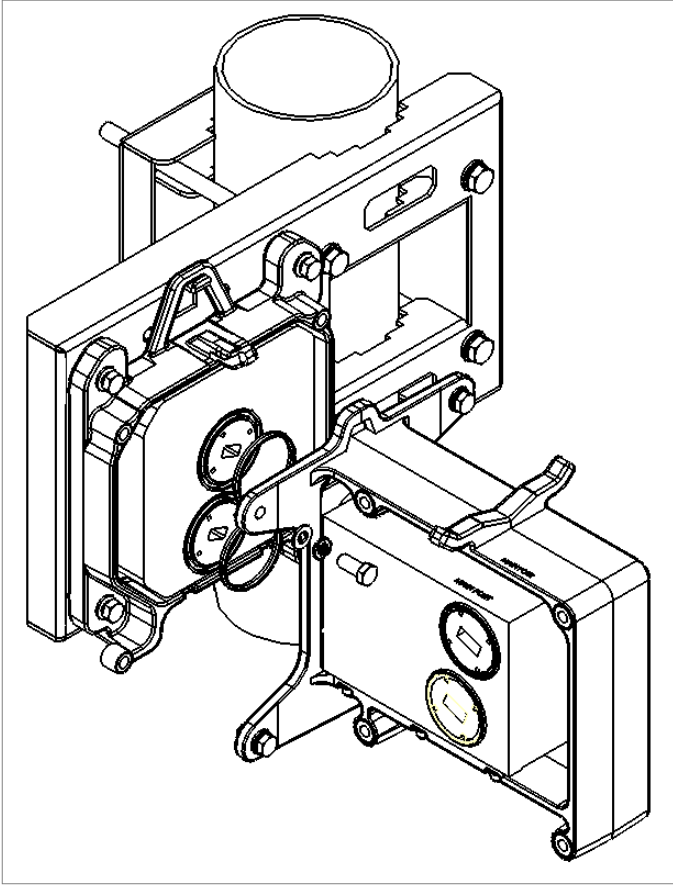

4. Mount and tighten the PTP 850CX unit to the PTP 820C Dual Coupler using the four screws and washers that are assembled to the PTP 850CX radio. Make sure that the O-rings are mounted on the PTP 820C Dual Coupler.

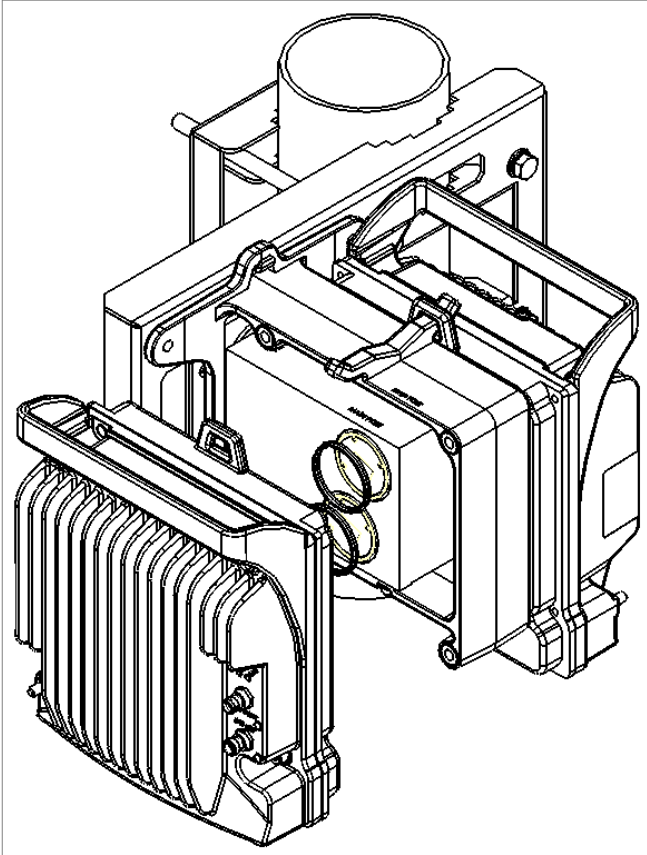

5. Connect the Flexible Waveguide and Sealing Gasket supplied with the Flexible Waveguide kit to the RFU-C Adaptor plate. Tighten the four screws supplied with the Flexible Waveguide kit.

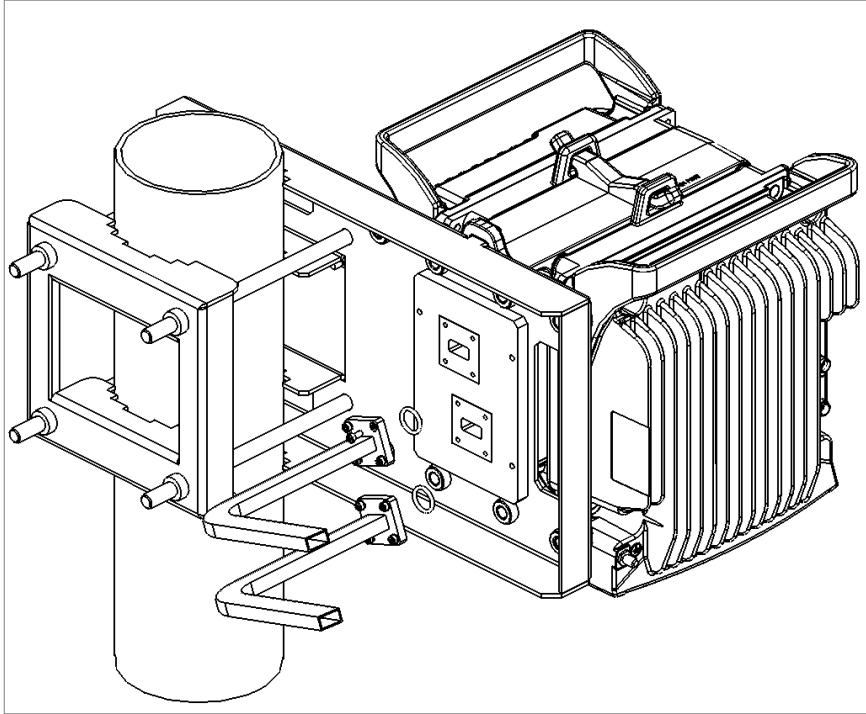

## 1+1 HSB-SD

### List of Items

Item	Description	Quantity	Remarks
1	PTP 850CX	2	
2	Flexible Waveguide Kit	2	
3	PTP 820C Dual Coupler/Splitter	1	

### Required Tools

- Metric offset hexagon key set
- Metric wrench key set

## 13 GHz

1. Mount and tighten the PTP 820-C Remote Mount Adaptor plate (supplied in PTP 820C Adaptor Remote Mount kit) to the PTP 820C Pole Mount using the four flat screws supplied with the PTP 820C Adaptor Remote Mount kit.

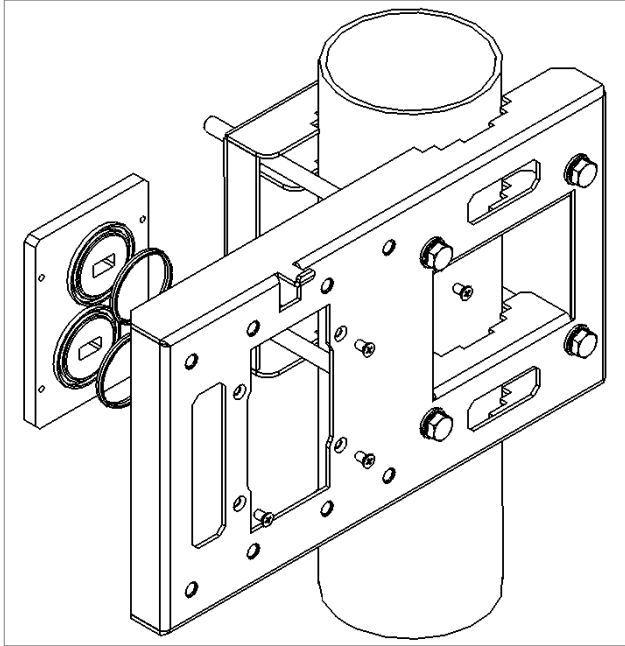

2. Mount and tighten the PTP 820C Dual Coupler to the PTP 820C Pole Mount using the four screws and washers that are supplied with the PTP 820C Dual Coupler kit. Pay attention that the O-rings are mounted on the PTP 820C Remote Mount Adaptor.

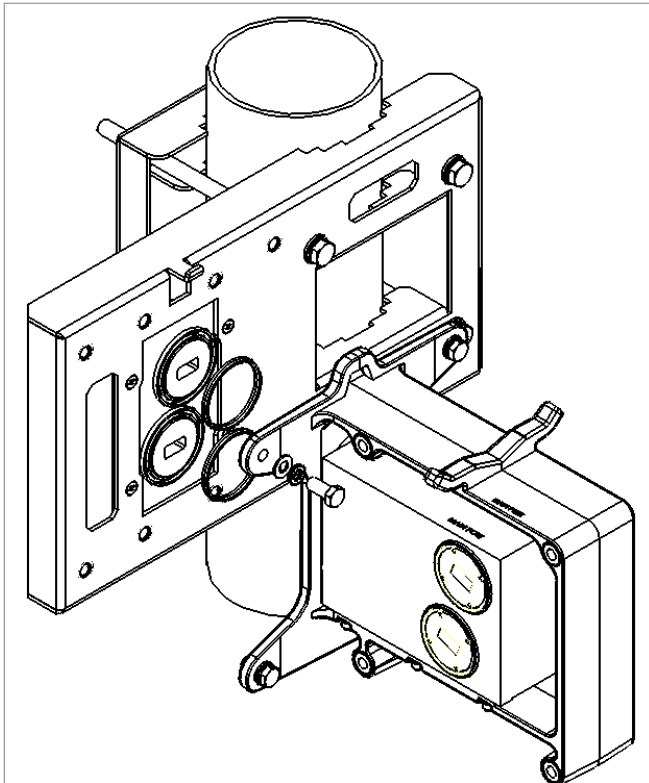

3. Mount and tighten the PTP 850CX radios on each side of the PTP 820C Dual Coupler using the screws assembled on PTP 850CX radio. Make sure that the O-rings are correctly assembled on the radio port of the PTP 820C dual coupler.

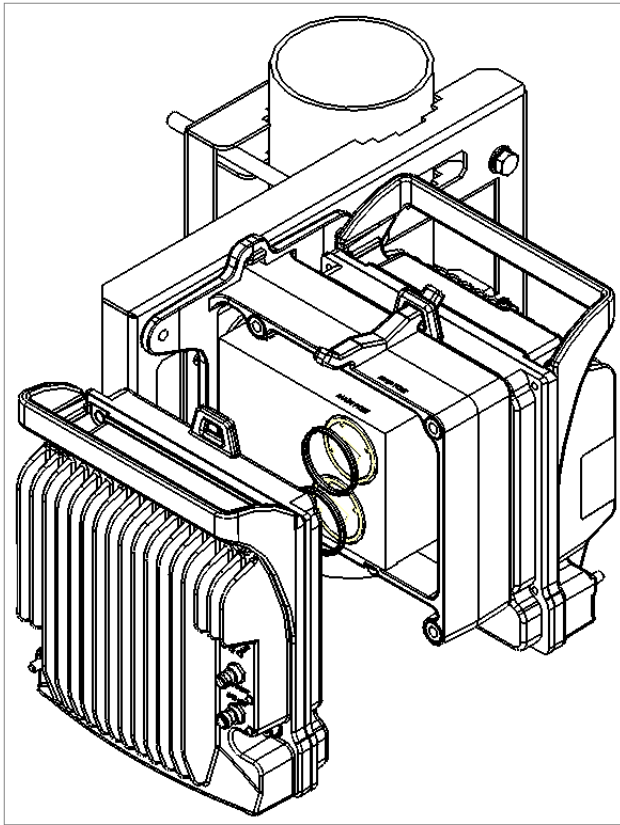

4. Connect both Flexible Waveguides and Sealing Gaskets supplied with each Flexible Waveguide Kit to the PTP 820C Dual Coupler antenna ports. Tighten the screws and washers supplied with the Flexible Waveguide Kit.

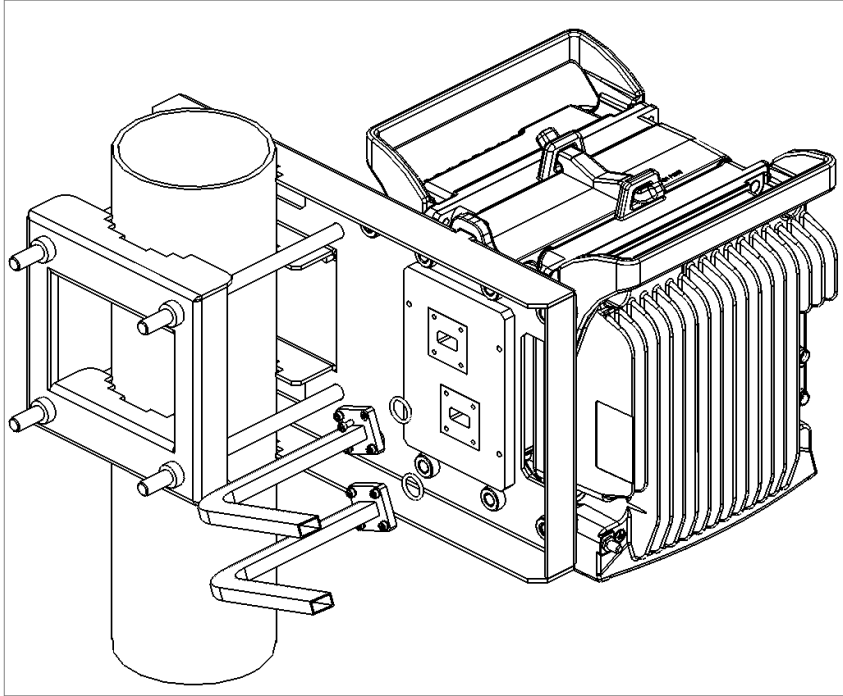

## 15-23 GHz

1. Mount and tighten the PTP 820C Dual Coupler to the PTP 820C DC Pole Mount using the four screws and washers supplied with the PTP 820C Dual Coupler kit.

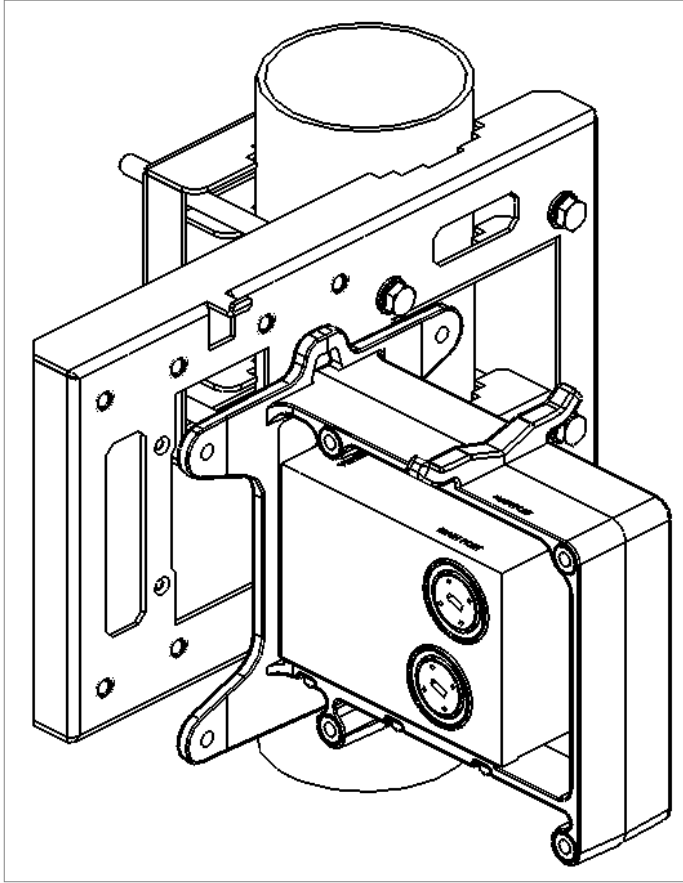

2. Mount and tighten the PTP 850CX radios on each side of the PTP 820C Dual Coupler using the screws assembled on the PTP 850CX radio. Make sure that the O-rings are correctly assembled on the radio port of the PTP 820C Dual Coupler.

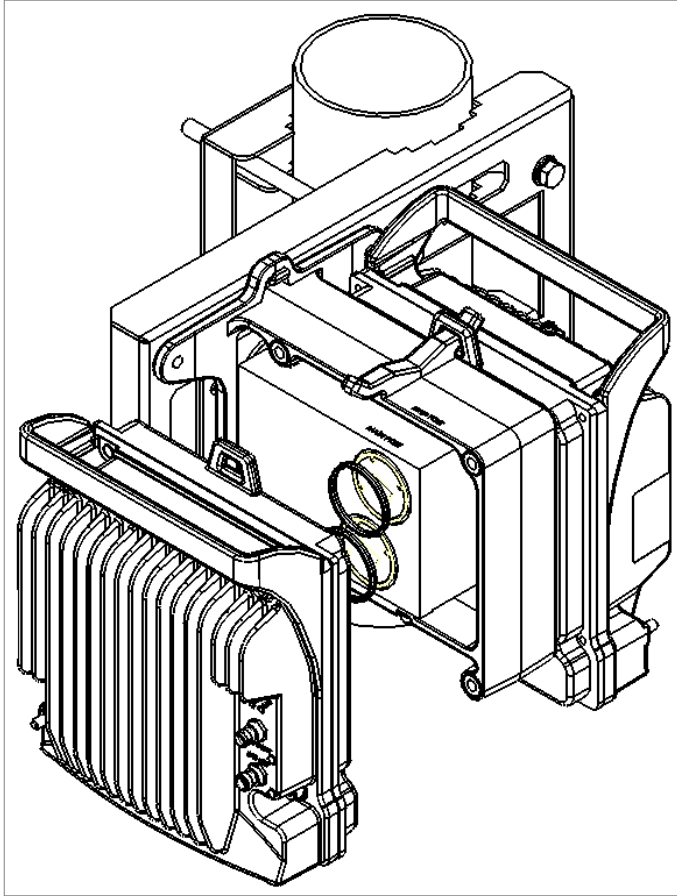

3. Mount the O-ring and the Flexible Waveguides to the PTP 820C Dual Coupler ports using the four screws supplied with the Flexible Waveguide kits.

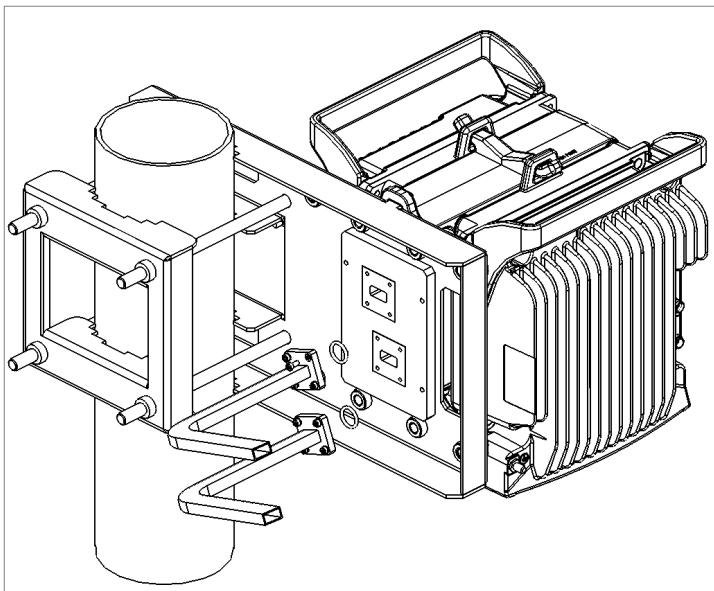

4. Mount and tighten the O-ring and the Flexible Waveguides to the antenna ports on the primary and diversity antennas using the four screws supplied with the Flexible Waveguide kits.



**Note:**

Verify that the O-rings are correctly mounted between the OMT ports and each Flexible Waveguide.

# Installing PTP 850CX on Third-Party Antenna Adaptors

Since the PTP 850CX uses the same antennas as PTP 820C and RFU-C, it can utilize the 3<sup>rd</sup> party mediation devices much in the same way they are used with PTP 820C and RFU-C installations.

Special attention must be taken in assembling these configurations, as the 3<sup>rd</sup> party adaptors can be used only for single polarization configurations.

In general, once the correct 3<sup>rd</sup> party adaptor has been selected and installed on the antenna, the interface now is identical to a generic single polarization PTP 820C or RFU-C interface. From this moment forth it is ready for any subsequent PTP 850CX configuration.

The following tables describe available adaptors:

**Table 37** 3<sup>rd</sup>-Party Adaptors, 6 GHz – 15 GHz

Other Vendors Antennas	13 GHz	15 GHz	18 GHz	23 GHz
RFU-C - NEC Adaptor kit (PASOLINK NEO)	ADPT_RFU-C13_15-NC_ANT		ADPT_RFU-C18_26-NEC_ANT	
RFU-C - ERICSSON Adaptor kit (RAU1)	ADPT_RFU-C13-ERCS_RAU1_ANT	ADPT_RFU-C15-ERCS_RAU1_ANT	ADPT_RFU-C18-ERCS_RAU1_ANT	ADPT_RFU-C23-26-ERCS_RAU1_ANT
RFU-C - ERICSSON Adaptor kit (RAU2)	ADPT_RFU-C13-ERCS_ANT	ADPT_RFU-C15-ERCS_ANT	ADPT_RFU-C18-ERCS_ANT	ADPT_RFU-C23-ERCS_ANT
RFU-C - SRAL (SIEMENS) Adaptor kit	MK-4162-0	MK-4163-0	ADPT_RFU-C18_26-SRAL_ANT	
RFU-C-NSN (Flexihopper) ADAPTOR KIT	ADPT_RFU-C13-N_ANT	ADPT_RFU-C15-N_ANT	ADPT_RFU-C18_26-N_ANT	
RFU-C - ALU Adapter Kit	ADPT_RFU-C13-ALU_Melody		ADPT_RFU-C18-ALU_Melody	
PTP 820C/S and RFU-C - Dragonwave Adapter Kit	ADPT-CIRC-		ADPT-CIRC-	ADPT-CIRC-

Other Vendors Antennas	13 GHz	15 GHz	18 GHz	23 GHz
	RFU-C_13-DW		RFU-C_18-DW	RFU-C_23-DW
Kit for converting a ValuLine 3 antenna for integration with RFU-C (ValuLine 3 antennas only). For important information on when these kits can be used, see <a href="#">Special Note on Converting ValuLine 3 Antennas</a> .	VINTA-13-CR4	VINTA-15-CR4	VINTA-18-CR4	VINTA-23-CR4



**Note:**

For instructions how to install these third-party adaptors, refer to the RFU-C Installation Guide.

## Special Note on Converting ValuLine 3 Antennas

Part numbers for ValuLine 3 antenna conversion kits are valid for most ValuLine 3 antennas, integrated or non-integrated. These conversion kits can also be used to convert CommScope ValuLine 3 antennas with the old Nera Evolution interface to RFU-C. The kits support the majority of CommScope’s ValuLine 3 antennas, 1-6ft. However, since there are some unique cases in which CommScope provided special antennas which are not supported by these adaptors, it is recommended that you supply your Cambium representative with a picture of the current antenna (back plain side), in order to confirm the antenna’s compatibility prior to implementing this solution.

You can also check the following to determine whether the antenna is compatible with the conversion kit:

- Verify that the antenna is, in fact, a ValuLine 3 antenna.
- Verify that the back plate of the antenna has in its holding plate the six mounting holes shown in red in the figure below.

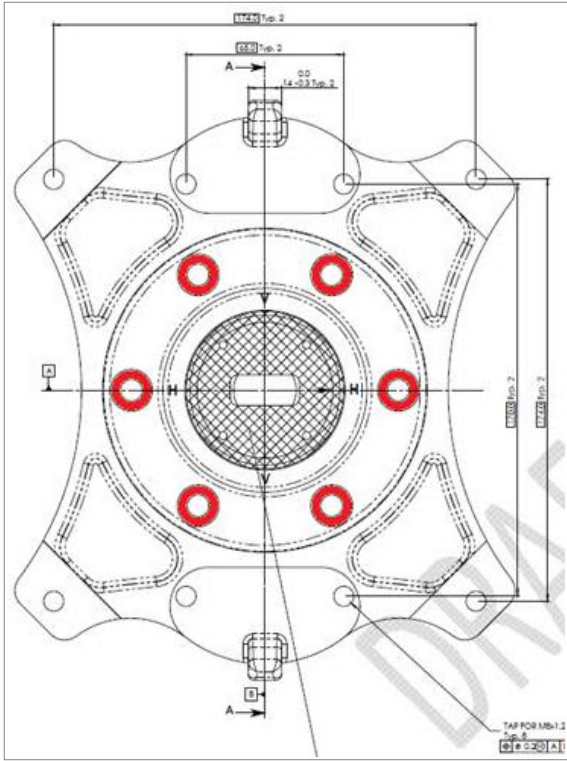

# Appendix A: Acceptance & Commissioning Procedures

This chapter provides Cambium's recommended Acceptance and Commissioning Procedure for PTP 850CX. Acceptance and commissioning should be performed after initial setup is complete.

The purpose of this procedure is to verify correct installation and operation of the installed link and the interoperability with customer end equipment.

Cambium's Acceptance and Commissioning procedure includes the following stages:

- Site Acceptance Procedure
- Commissioning of Radio Link

The Site Acceptance Procedure is a checklist that summarizes the installation requirements of the site at which the products were installed.

The commissioning tests cover the required configuration information that should be recorded, and the tests that should be performed on the radio link.

## Site Acceptance Procedure

The purpose of the following procedures is to verify that all installation requirements were noted and checked. Following this procedure will ensure proper, long-lasting, and safe operation of the product.

The checklist below summarizes the installation requirements of the site.

SITE ACCEPTANCE CHECKLIST	
1. SITE INFORMATION	
Customer:	
Radio model:	
Site name:	
Site code:	
Radio link code:	
Site address:	
2. ANTENNA MOUNTING	
Antenna mount type:	
Mount is of sufficient height to clear local obstructions	OK
Mount is safely positioned to not cause a safety hazard	OK
Mount is secure and perpendicular	OK

<b>SITE ACCEPTANCE CHECKLIST</b>	
Mount is grounded as per site specifications	OK
All steelwork is Galvanized or Stainless Steel as appropriate	OK
<b>3. ANTENNA</b>	
Antenna type (model and size):	
Antenna is securely fixed to mount	OK
Antenna is grounded as per site specifications	OK
Antenna sway braces are installed correctly (where applicable)	OK
Antenna Radome is securely fitted (where applicable)	OK
Water drain plugs are fitted and removed, as appropriate	OK
Antenna sealing O-Ring is properly fitted and not damaged	OK
Antenna/Launch unit polarization is as per link requirements	OK
<b>4. OUTDOOR UNIT</b>	
Type of ODU mount:	(Direct or Remote mount)
ODU is securely mounted to the antenna or pole	OK
ODU is grounded as per installation instructions	OK
ODU's polarization is as per link requirements	OK
ODU is installed properly and has no physical damage	OK
For Remote-Mount Only:	
Remote mount kit is securely mounted to the pole	OK
Flexible waveguide has no physical damage and connectors are sealed	OK
All flexible waveguide bolts are secured using washers and lock-washers, as appropriate	OK
Flexible waveguide is secured to the pole	OK
<b>6. CAT5/Fiber Optic CABLE</b>	
Overall cable length:	
Cable type:	
CAT5 connectors assembled properly on the cable	OK
Cable connected securely to ODU and IDU	OK
Cable connector is covered by gland and secure by cable tie at the ODU	OK

<b>SITE ACCEPTANCE CHECKLIST</b>	
At the ODU, cable has a service/drip loop to prevent moisture from entering the connector	OK
Cable is secured using suitable restraints to fixed points at regular intervals (0.5 m recommended)	OK
Cable has no sharp bends, kinks, or crushed areas. All bends are per manufacturer specifications	OK
Grounding is as per site specifications	OK
Cable point-of-entry to building/shelter is weather-proof	OK
Cable ends are properly labeled	OK
<b>7. FLEXIBLE WAVEGUIDE</b>	
Overall flexible WG length:	
Flexible WG type:	
Flexible WG is connected securely to ODU and Antenna	OK
Flexible WG connector is weather-proofed (sealed) at the ODU	OK
At the ODU, the flexible WG has a service/drip loop to prevent moisture from entering the connector	OK
Flexible WG is secured using suitable restraints to fixed points at regular intervals (0.5 m recommended)	OK
Flexible WG has no sharp bends, kinks, or crushed areas. All bends are per manufacturer specifications	OK
Flexible WG point-of-entry to building/shelter is weather-proof	OK
Flexible WG ends are properly labeled	
<b>8. DC POWER SUPPLY - Two Inputs</b>	
Measured DC voltage input to the IDU:OK	(-40.5 to -60 VDC)
Power-Supply maximum current:	
Power-Supply is properly grounded	OK
DC power backup type:	
IDU DC connector is secure and the DC input leads are correctly terminated (no bare wires are visible)	OK
IDU DC connector (+) and (GND) leads are shorted and GND is grounded	OK
<b>9. RACK INSTALLATION</b>	

SITE ACCEPTANCE CHECKLIST	
Rack is mounted to the shelter floor with four screws	
Rack is mounted to the shelter wall with two screws	
10. REMARKS/NOTES	
11. GENERAL INFORMATION	Name:
Site accepted by:	Title:
	Company:
	Signature:
	Date:
Site approved by:	Name:
	Title:
	Company:
	Signature:
	Date:

## Site Acceptance Checklist Notes

The following notes provide important additional information about the Site Acceptance Checklist.

### 1. Antenna Mounting

- Mounting pole is of sufficient height to clear local obstructions, such as parapets, window cleaning gantries, and lift housings.
- Mounting Pole is of sufficient height, and is safely positioned, so as not to cause a safety hazard. No person should be able to walk in front of, or look directly into the path of the microwave radio beam. Where possible, the pole should be away from the edge of the building.
- Mounting pole is secure and perpendicular. A pole that is not perpendicular may cause problems during antenna alignment.
- Mounting pole is grounded as per site specifications. All operators and site owners have specific requirements regarding the grounding of installations. As a minimum, typical requirements are such that any metal structure must be connected to the existing lightning protection ground of the building. Where it extends beyond the 45 degree cone of protection of existing lightning

conductors, additional lightning protectors should be installed.

- All steelwork is Galvanized or Stainless Steel, as appropriate to prevent corrosion.

## 2. Antenna

- Antenna is grounded as per site specifications. See the third point in the Antenna Mounting section above.
- Antenna sway braces are fitted and installed correctly, where applicable. Typically, for an antenna of 1.2 m or larger, an extra sway brace is fitted to the mounting frame of the antenna. This sway brace should not be mounted to the same pole as the antenna, but should be installed directly back to the tower or an alternative point.
- Antenna Water Drain Plugs are fitted and removed, where appropriate. Some antennas have moisture drain plugs installed at various points around the antenna. The purpose of these plugs is to allow any moisture that forms on the inside of the antenna or radome to drip out and prevent a pool within the antenna. Only the plugs at the bottom of the antenna, after installation, should be removed. All other plugs should be left in position.

## 3. ODU (Outdoor Unit)

- The ODU is grounded as per installation instructions. See the third point in the Antenna Mounting section above.
- The ODU polarization is as per link requirements and matches the polarization of the antenna.
- The main traffic connections are correctly terminated and crimped as per cable and connector manufacturer instructions. All fiber optic patch leads should be routed carefully and efficiently, using conduits to prevent damage to the cables.
- All other user terminations are secure and correctly terminated.
- All labeling is complete as per site requirements. Labeling is specific to each customer. At a site with only one installation, labeling may be unnecessary. However, at sites with multiple installations, correct and adequate labeling is essential for future maintenance operations.

Typical labeling requirements include:

- Antenna labels - for link identity and bearing
- ODU labels - for link identity, frequency, and polarization
- Cat5/Fiber cable labels - for link identity, close to the ODU, switch, and either end of any joint
- Switch labels - for link identity

# Radio Link Commissioning Procedure

## Scope

This section describes the recommended commissioning tests for PTP 850CX radio link in a 1+0 configuration.

The purpose of the commissioning tests is to verify correct and proper operation of the product.

# Commissioning Test

The following tests should be performed on each installed link.

## Link Verification

- Received Signal Level (RSL) is up to +/- 4 dB from the expected (calculated) level at both ends of the link.



**Note:**

The voltage at the RSL port is 1.XX where XX is the RSL level. For example: 1.59V means an RSL of -59 dBm. Note that the voltage measured at the RSL port is not accurate and should be used only as an aid).

- Radio Bit Error Rate (BER) is  $10E^{-11}$  or lower.
- If working with ATPC, ATPC is operating as expected (RSL = reference level).

## Ethernet Line Interfaces Test

- Connect Ethernet Packet Analyzer to the GbE port. Use physical loop at remote end (or connect second analyzer). Run Packet Loss test for at least one hour (load rate as per Cambium's specifications for the chosen MRMC).
- Connect Ethernet Packet Analyzer to the FE port. Use physical loop at remote end (or connect second analyzer). Run Packet Loss test for at least one hour (load rate as per Cambium's specifications for the chosen MRMC).

## Interoperability Verification

- Connect customer end equipment to the line interfaces, and verify correct operation.
- Further interoperability tests should be performed in accordance with the specific requirements of the connected end equipment.

## Management Verification

- Launch the HTTP management and verify that you can manage the link and that you are able to perform changes to the link configuration (frequency channel, Tx power, system name, time & date, etc.)
- Verify that correct parameters are reported when performing the above.
- Verify that there are no active alarms on the link.
- If the management station is located at a remote site (Network Operation Center), verify that the management station can manage the link and receive traps.

# PTP 850CX Commissioning Log

The Commissioning Log is an integral part of the commissioning procedure and should be filled in for each installed link.

The Commissioning Log gathers all relevant information regarding the installed link and contains a checklist of all recommended commissioning tests.

Maintaining the Commissioning Log is important for tracking your installations, and to provide essential data for Cambium Networks.

Upon completing the Commissioning Log, send the log to Cambium support center at [support@Cambium.com](mailto:support@Cambium.com).

PTP 850CX LINK COMMISSIONING LOG		
1. GENERAL INFORMATION		
Customer:		
Radio model:		
Configuration:		
Radio link code:		
Site 1 name & add:		
Site 2 name & add:		
2. ODU/RFU	Site 1	Site 2
ODU model:		
ODU p/n:		
ODU s/n:		
ODU SW:		
Tx frequency (MHz):		
Rx frequency (MHz):		
Link ID:		
Tx power (dBm):		
ATPC on/off:		
ATPC ref level:		
ODU Polarization:		
3. ANTENNA AND ODU MOUNT		
Antenna vendor and model:		

<b>PTP 850CX LINK COMMISSIONING LOG</b>		
Antenna size:		
Mounting type:		
Mounting losses:		
<b>4. LINK PARAMETERS</b>		
Link distance:		
Rain zone:		
Expected RSL (dBm):		
Expected Diversity RSL (dBm):		
RSL Main (dBm):		
RSL Diversity (dBm):		
Deviation from exp?		
RSL ≤4 dB?		
<b>5. COMMISSIONING TESTS</b>		
Line loopback:	Pass	Pass
ODU loopback:	Pass	Pass
Radio BER:	Pass	Pass
FE test:	Pass	Pass
GbE test:	Pass	Pass
<b>6. MANAGEMENT CONFIGURATION</b>		
Eth IP Address:		
Eth IP mask:		
Default router:		
In-band VLAN		
<b>7. REMARKS/NOTES</b>		
<b>8. INSTALLATION INFORMATION</b>		

**PTP 850CX LINK COMMISSIONING LOG**

Installed by:	Name:	
	Company:	
	Signature:	
	Date:	
Commissioned by:	Name:	
	Company:	
	Signature:	
	Date:	

# Cambium Networks

---

Cambium Networks delivers wireless communications that work for businesses, communities, and cities worldwide. Millions of our radios are deployed to connect people, places, and things with a unified wireless fabric that spans multiple standards and frequencies of fixed wireless and Wi-Fi, all managed centrally via the cloud. Our multi-gigabit wireless fabric offers a compelling value proposition over traditional fiber and alternative wireless solutions. We work with our Cambium certified Connected Partners to deliver purpose built networks for service provider, enterprise, industrial, and government connectivity solutions in urban, suburban, and rural environments, with wireless that just works.

Support website	<a href="https://support.cambiumnetworks.com">https://support.cambiumnetworks.com</a>
Support enquiries	
Technical training	<a href="https://learning.cambiumnetworks.com/learn">https://learning.cambiumnetworks.com/learn</a>
Main website	<a href="https://www.cambiumnetworks.com">https://www.cambiumnetworks.com</a>
Sales enquiries	<a href="mailto:solutions@cambiumnetworks.com">solutions@cambiumnetworks.com</a>
Warranty	<a href="https://www.cambiumnetworks.com/support/standard-warranty/">https://www.cambiumnetworks.com/support/standard-warranty/</a>
Telephone number list	<a href="https://www.cambiumnetworks.com/contact-us/">https://www.cambiumnetworks.com/contact-us/</a>
User Guides	<a href="https://www.cambiumnetworks.com/guides">https://www.cambiumnetworks.com/guides</a>
Address	Cambium Networks Limited, Unit B2, Linhay Business Park, Eastern Road, Ashburton, Devon, TQ13 7UP United Kingdom



[www.cambiumnetworks.com](http://www.cambiumnetworks.com)

Cambium Networks and the stylized circular logo are trademarks of Cambium Networks, Ltd. All other trademarks are the property of their respective owners.

Copyright © 2026 Cambium Networks, Ltd. All rights reserved.