



QUICK START GUIDE

Fiber OLT and ONT

Release 1.3.0



Reservation of Rights

Cambium reserves the right to make changes to any products described herein to improve reliability, function, or design, and reserves the right to revise this document and to make changes from time to time in content hereof with no obligation to notify any person of revisions or changes. Cambium recommends reviewing the Cambium Networks website for the latest changes and updates to products. Cambium does not assume any liability arising out of the application or use of any product, software, or circuit described herein; neither does it convey license under its patent rights or the rights of others. It is possible that this publication may contain references to, or information about Cambium products (machines and programs), programming, or services that are not announced in your country. Such references or information must not be construed to mean that Cambium intends to announce such Cambium products, programming, or services in your country.

Copyrights

This document, Cambium products, and 3rd Party software products described in this document may include or describe copyrighted Cambium and other 3rd Party supplied computer programs stored in semiconductor memories or other media. Laws in the United States and other countries preserve for Cambium, its licensors, and other 3rd Party supplied software certain exclusive rights for copyrighted material, including the exclusive right to copy, reproduce in any form, distribute and make derivative works of the copyrighted material. Accordingly, any copyrighted material of Cambium, its licensors, or the 3rd Party software supplied material contained in the Cambium products described in this document may not be copied, reproduced, reverse engineered, distributed, merged or modified in any manner without the express written permission of Cambium. Furthermore, the purchase of Cambium products shall not be deemed to grant either directly or by implication, estoppel, or otherwise, any license under the copyrights, patents or patent applications of Cambium or other 3rd Party supplied software, except for the normal non-exclusive, royalty free license to use that arises by operation of law in the sale of a product.

Restrictions

Software and documentation are copyrighted materials. Making unauthorized copies is prohibited by law. No part of the software or documentation may be reproduced, transmitted, transcribed, stored in a retrieval system, or translated into any language or computer language, in any form or by any means, without prior written permission of Cambium.

License Agreements

The software described in this document is the property of Cambium and its licensors. It is furnished by express license agreement only and may be used only in accordance with the terms of such an agreement.

High Risk Materials

Cambium and its supplier(s) specifically disclaim any express or implied warranty of fitness for any high-risk activities or uses of its products including, but not limited to, the operation of nuclear facilities, aircraft navigation or aircraft communication systems, air traffic control, life support, or weapons systems ("High Risk Use").

This product is not restricted in the EU. Any High Risk is unauthorized, is made at your own risk and you shall be responsible for any and all losses, damage or claims arising out of any High-Risk Use.

Contents

Contents	3
Introduction	5
Product Description	6
OLT	7
Cambium ONTs	8
Indoor ONT	8
Outdoor ONT	9
Installation of OLT and ONTs	12
Installing the OLT	12
Taking safety precautions	12
Selecting a location	13
Rack mounting	13
Using required tools and equipment	13
Installing OLT	14
Connecting/disconnecting the AC power cord	16
Installing a transceiver	17
Connecting a fiber optic cable	20
Installing the ONTs	20
Installing the indoor ONT	20
Installing the outdoor ONT	22
User Interface (UI) Configuration	26
OLT UI configuration	26
Configuring the management PC	26
Logging in to OLT UI	28
Configuring the OLT management IP address	33
Zero touch provisioning	34

ONT UI configuration	35
Logging in to ONT UI	35
Software upgrade	36
Pluggable ONU	37
Software Update	38
Cambium Networks	39

Introduction

Fiber Optical Line Terminal (OLT) from Cambium Networks is a Passive Optical Network (PON), which connects to a core switch by an Ethernet cable or a fiber cable.

The primary functions of OLT are:

- To convert, frame and transmit, and receive signal for the Passive Optical Network (PON), 10-Gigabit Symmetrical Passive Optical Network (XGS-PON), and combo-PON networks
- To coordinate the Optical Network Terminals (ONT) multiplexing for the shared upstream transmission

Figure 1 is an example of the PON network architecture.

Figure 1: *The PON network architecture*

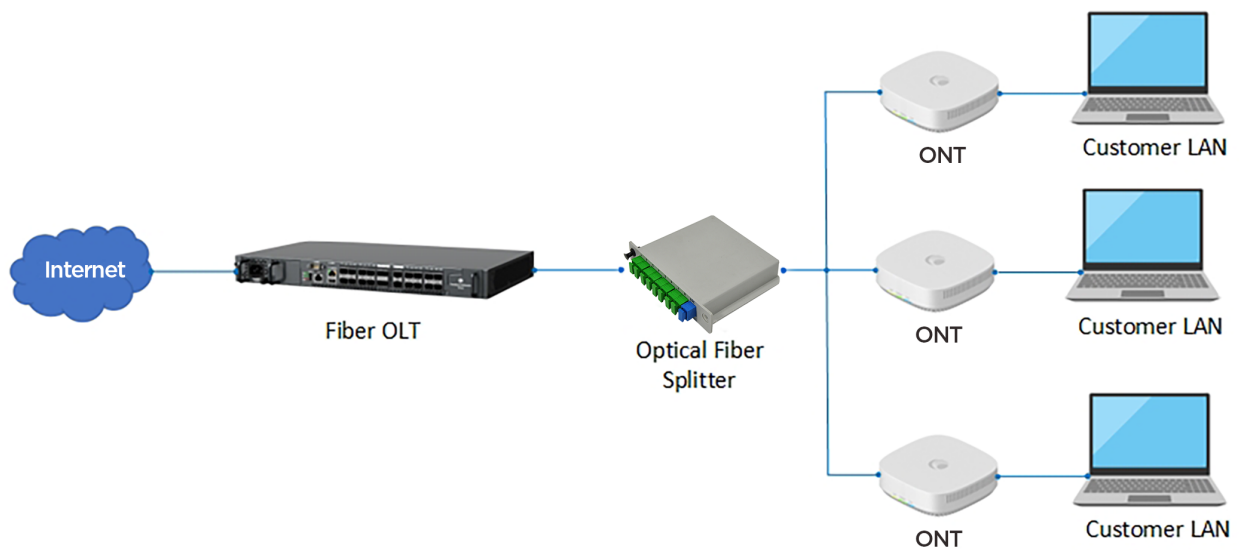

Product Description

OLT is a GPON, XGS-PON, and Combo PON (GPON co-existing with XGS-PON) Optical Defined Networking (ODN) access OLT. Its high-performance access design focuses on SDN deployments. It provides an open interface to all control management functions for an easy integration with an SDN environment.

OLT includes eight AIO PON interfaces to support multiple PON technologies, simultaneously. It is used to develop the network with GPON using User Network Interface (UNI) ports. OLT is a part of the GPON solution network used for delivering broadband data, high-quality voice, and IP television through the following devices:

- Fiber to the curb (FTTC) connections for standalone VDSL Outside Plant (OSP) Multi-Dwelling Unit (MDU) devices.
- Fiber to the building (FTTP) or neighborhood (FTTN) connections for chassis-based MDU devices.
- Fiber to the home (FTTH) connections for ONT subscriber devices.

The carrier-grade, temperature-hardened compact hardware design of OLT provides service providers deployment flexibility for diverse environments. With this design, you can create network, achieve market goals of OLT, and satisfy future network needs.

OLT with the temperature-hardened hardware has the following design features:

- Redundant AC or DC power module options
- A resilient 4+1 fan module with side-to-side and left-to-right airflow
- 260 mm depth
- All front access interfaces allow flexible installation, ranging from data centers to street-cabinets in remote locations.

This topic contains the following sections:

- [Front panel view of OLT](#)
- [Front panel view of ONTs](#)

OLT

Figure 2 shows the front panel view of OLT.

Figure 2: Front panel view of OLT

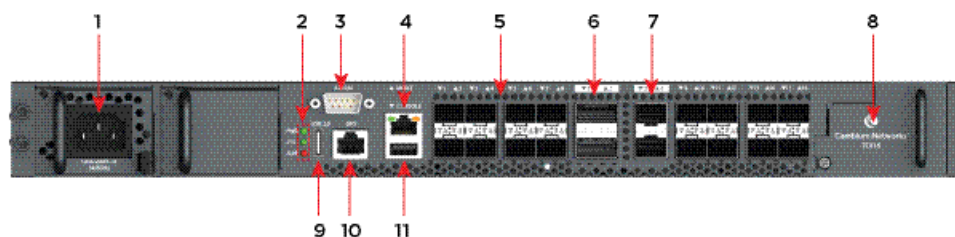

Table 1 lists and describes the components of OLT.

Table 1: OLT components

Item	Component	Description
1	Dual Power Modules	<p>Dual power module slots are used for redundancy. Connect AC/DC power sources to the modules.</p> <p>AC power module</p> <p>Operating voltage: 100 to 240 VAC, 50/60 Hz 3.5 Amps maximum.</p> <p>Fuse: T6.3A 250 VAC.</p> <p>DC power module</p> <p>Operating voltage: -38.4 to -72 V DC, normal -48 V input. There is no tolerance for the DC input voltage.</p> <p>Maximum DC input current: 290 Watts; 7.56 Amps at -38.4 V DC.</p> <p>Fuse: T10A 250 VAC.</p>
2	LEDs	Indicates the status of the system.
3	Alarm	Use this male 9-pin external alarm input/output connector to connect mechanical cabinet parts with the management networks for remote monitoring.
4	Management port	Use an Ethernet cable to connect the system to the RJ-45 out-band management port for local configuration.
5	1-16 AIO PON Downlink	16 AIO PON SFP+ slots, each slot supports a GPON, XGS-PON, or Combo-PON (GPON co-existing with XGS-PON) transceiver.
6	1-2 (QSFP28 Uplink)	Two QSFP28 slots. Each supporting 1 x 100 GbE or 1 x 40 GbE.
7	3-4 (SFP28 Uplink)	Two SFP28 slots. Each supporting 1 x 25 GbE or 1 x 10 GbE.

Item	Component	Description
8	Swappable fan module	Swappable fan module to reduce the heat inside the OLT.
9	USB port 2.0	Use USB disk with this USB 2.0 interface to upgrade software and transfer files to the Type-7 COM Express module.
10	GPS	Reserved for future use. One RJ-45 (RS422) connector used to connect a GPS receiver to provide Time-of-Day (ToD) and 1 Pulse-per-second (1 pps) timing information.
11	Console	Use an USB type A cable to connect the system for local serial configuration.

shows specifications for OLT.

Specification	Description
Wire gauge specifications	<p>Ground wires: 18 AWG or larger (for multicore cables).</p> <p>Power wires: 16 AWG or larger.</p>
Operating environment	Temperature: -40°C to +65°C (-40°F to +149°F).



Note

The 1-16 AIO interface is applicable to 16-port OLT and the 1-8 AIO interface is applicable to 8-port OLT.

For more information, refer to the *OLT and ONT User Guide*.

Cambium ONTs

Cambium ONTs terminate an Optical Access Network (OAN) providing a subscriber port intended for a single subscriber. This topic contains the following sections:

- [Indoor ONT](#)
- [Outdoor ONT](#)
- [Interfaces of indoor ONT](#)
- [Interfaces of outdoor ONT](#)
- [LEDs on ONT](#)

Indoor ONT

Figure 3 shows the front view of indoor ONT.

Figure 3: Front view of indoor ONT



Figure 4 shows the rear view of the indoor ONT.

Figure 4: Rear view of indoor ONT

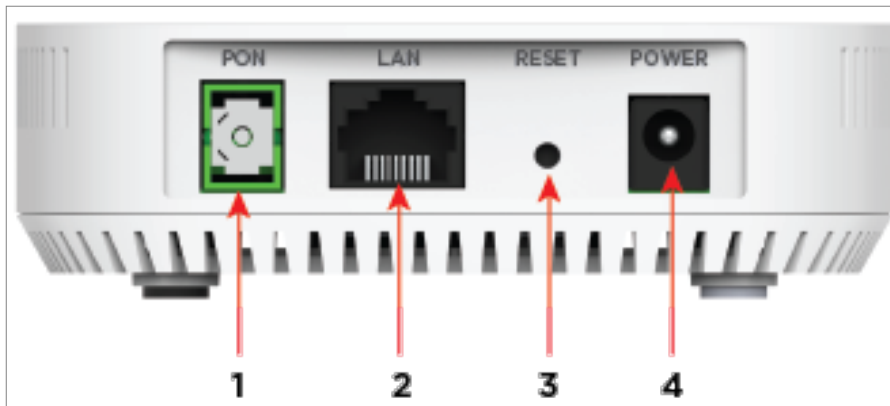

Table 2: Fiber indoor ONT components

Ports	Component	Description	
		GPON ONT (SGX Series)	XGS-PON ONT (SXX Series)
1	PON	GPON	XGS-PON
2	LAN	1 Gigabit Ethernet	2.5 Gigabit Ethernet
3	RESET	Reset button	Reset button
4	POWER	Power button	Power button

Outdoor ONT

Figure 5 shows the front view of outdoor ONT.

Figure 5: Front view of outdoor ONT



Figure 6 shows the ports of outdoor ONT.

Figure 6: Outdoor ONT ports

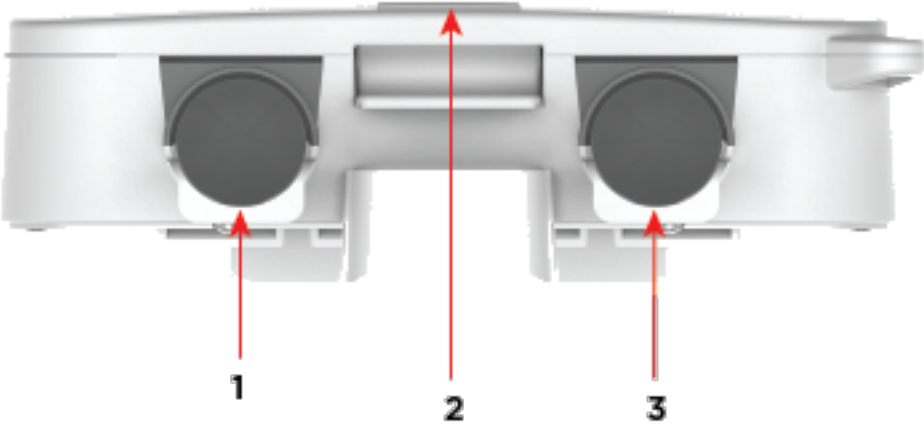

Table 3: Fiber outdoor ONT interfaces

Ports	Interfaces	Description	
		GPON ONT (SGT Series)	XGS-PON ONT (SXT Series)
1	PoE Ethernet Port	Power over Ethernet (PoE)	Power over Ethernet (PoE)
2	RESET	Reset button	Reset button
3	PON port	GPON	XGS-PON

Installation of OLT and ONTs

This topic explains about the installations procedures of OLT and ONTs.

This topic contains the following sections:

- [Installing the OLT](#)
- [Installing the ONTs](#)

Installing the OLT

This section explains the installation procedures of the OLT hardware appliance using the available mounting options. OLT is shipped with an accessory kit that includes the equipment needed to install the OLT in a standard, 19-inch Telco rack.

Installing OLT involves the following procedures:

- [Taking safety precautions](#)
- [Selecting a location](#)
- [Rack mounting](#)
- [Using required tools and equipment](#)
- [Installing OLT](#)
- [Connecting/Disconnecting the AC power cord](#)
- [Installing a transceiver](#)
- [Connecting a fiber optic cable](#)

Taking safety precautions

Before installing OLT, take the following safety precautions:

- Ensure that the rack is correctly and securely installed to prevent it from falling or becoming unstable.
- Dangerous voltage above 240V AC is always present while the power supply module is plugged into an electrical outlet. Remove all rings, jewelry, and other potentially conductive material before working with this device.
- Never insert foreign objects into the chassis, power supply, or any other component even when the power supply is turned OFF, unplugged, or removed.
- Ensure that the main power is fully disconnected from the equipment by unplugging all power cords from their outlets. For safety, verify that the power outlets and plugs are easily reachable by the operator.
- Do not handle electrical cables, which are not insulated including network cables.
- Keep water and other fluids away from the equipment to minimize electrical hazards.

- Comply with electrical grounding standards during all phases of installation and operation of the product. Do not allow the equipment chassis, network ports, power supply, or mounting brackets to contact any device, cable, object, or person attached to a different electrical ground. Also, do not connect the device to external storm grounding sources.
- Perform installation or removal of the chassis or any module in a static-free environment. Proper use of anti-static body straps and mats are strongly recommended.
- Installation must be performed by a trained professional. Use only included/recommended cables, power cords, AC power supplies, and batteries. The power cord should not be used with other electric equipment other than specified by Cambium Networks.
- The product module must be kept in anti-static packaging when it is not installed in the chassis.
- Do not ship or store this product near strong electromagnetic, electrostatic, magnetic, or radioactive fields.
- Do not disassemble the chassis.

Selecting a location

Consider the following criteria while selecting a location before installing OLT:

- **Reliable power** - Ensure that the electrical outlet is compatible with OLT (from Cambium Networks).
- **Cool, non-condensing ventilation** - For proper operation, OLT requires an environment with an ambient air temperature between 0° C and 40° C (32° F and 104° F). Humidity must be kept at non-condensing levels, between 5% and 95%. If a large number of electrical devices are working in the same area, then additional air conditioning or air circulation equipment may be required.
- **Ample space** - For proper air circulation, leave at least 10 cm (4 inches) clearance all around the chassis. Leave additional space in front of the chassis to access power cords, network cables, and indicator LEDs.
- **Limited electromagnetic interference** - For the best operation, keep OLT, all cords, and cables at minimum 0.7 meters (2 feet) from fluorescent lighting fixtures, and 2 meters (6 feet) from photocopiers, radio transmitters, electric generators, and other sources of strong electromagnetic interference.



Attention

The qualified service personnel is required to install OLT in a restricted access area, such as basement of the building or telco room.

Rack mounting

The OLT package (from Cambium Networks) includes a rack mounting option. This mounting option allows to mount OLT on two post 19-inch Telco rack. Use the rack mounting kit and the directions to mount OLT on an EIA standard size, 19-inch rack or in a wiring closet with other equipment.



Caution

All installation methods must be in accordance with national and local regulations and practices.

Using required tools and equipment

Use the following tools and equipment to install OLT:

- Mounting bracket (x 2), which is included in the kit: Do not use it for table or shelf installation.
- Screws for mounting bracket (x 4): M3 x 6.5 mm Phillips Flat Head Screws (included in the kit).
- Screws for system rack mount (x 4): M6 x 15 mm Phillips Pan Head Screws (included in the kit).
- Suitable Phillips head screwdrivers for all screw types provided in the box (not included in the kit).



Note

Some racks may require different screws other than the ones included in the kit. Ensure that you have the correct screws before installing OLT.

Installing OLT

This section explains how to install OLT, connect the power chord, install a transceiver, and connect cables.

Prerequisites

Consider the following prerequisite tasks before installing OLT:

- Ensure that the rack can safely support the combined weight of all the equipment.
- Take all necessary precautions to secure the rack before installing the unit. Ensure that the position of OLT does not make the rack unstable or top-heavy.
- Do not connect any power supplies to OLT.

Installation

Perform the following steps to install OLT on a two post 19-inch Telco rack:

1. Position a mounting bracket on one side of OLT. Then, align the screw holes on the bracket and the mounting holes on OLT.



2. Using a #2 Phillips screwdriver, install the 4 x M3 flat head screws through the mounting bracket holes into OLT.
3. Repeat Step 1 and Step 2 to install the second mounting bracket on the other side of OLT.



Note

Leave a minimum of 10 cm (4 inches) of space on the front, left, and right sides of the equipment for proper airflow and ventilation. Leave additional space at the front of OLT to access network cables, LED status indicators, and power cords.

Ensure that there are no obstructions to limit the airflow for the left and front side of the unit and the right side exhaust.

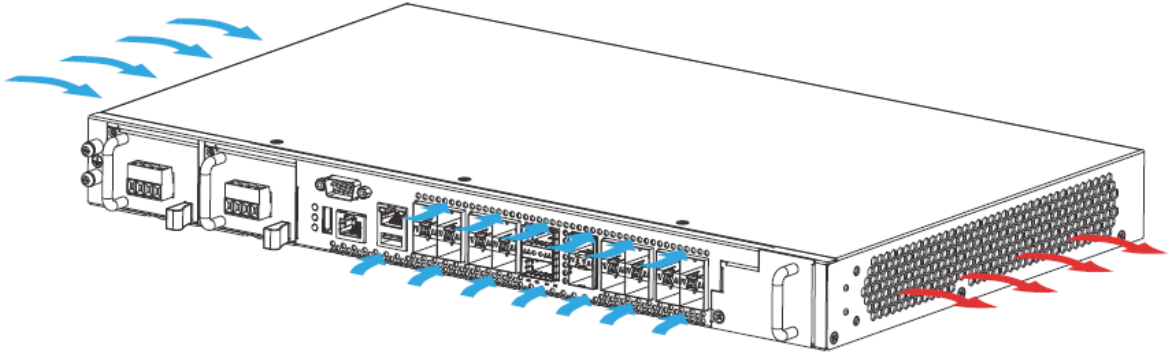

4. Use the four screws to install OLT on the rack.



Attention

Two persons are required to mount and secure OLT on the rack. One person needs to hold OLT in place, and another person must insert and tighten the screws.

Grounding

Connect the frame ground of OLT to a protective earthing terminal to protect against lightning and electrical interference.



Attention

Qualified service personnel must confirm that the protective earthing terminal is a valid terminal.

Perform the following steps to ground OLT:

1. Remove one of the M4 ground screws from the front panel of OLT.
2. Secure the green/yellow ground cable to the front panel of OLT using the M4 ground screw.
3. Attach other end of the cable to the ground, either to the same ground electrode as the rack where the device is installed or to the main grounding electrode of the building. If suitable grounding is not available, contact the appropriate electrical inspection authority or an electrician.



Warning

Connect the frame ground before connecting any other cables or wires.

Connecting/disconnecting the AC power cord

After the installation is complete, power on the device. The device is not equipped with an ON/OFF switch and powers on when the AC power cord is connected to the AC inlet and an AC power outlet. The AC power module has higher priority than the DC power module. When AC and DC power modules are connected simultaneously, the AC power module supplies power to the device. It supports up to two AC power modules and AC + DC power supply combination.

The Power module position is not fixed and either AC or DC power module can be installed on left or right power module slots. The AC power input can be monitored by the I2C to the CPU. It has hot-swappable redundant power modules of 100 VAC to 240VAC single phase, and operates from 50 Hz to 60 Hz.

Connecting the AC power cord

Perform the following steps to connect the AC power cord to OLT:

1. Plug in the AC power cord female connector to OLT power in socket.
2. Insert the three pin AC power cord into the AC power connector on the wall socket.
3. Ensure both the ends of AC power cord are firmly fixed with socket.
4. Power on the wall socket and the device receives the power.

Disconnecting the AC power cord

Perform the following steps to disconnect the AC power cord from OLT:

1. Switch off the power source in a socket.
2. Lift the power cord retaining clip off the AC power cord.
3. Pull the AC power cord from the power supply module.

The device turns off.

Installing a transceiver



Warning

- Avoid looking directly into the ends of OLT or the SFP modules. This can severely damage your eyes.
- Do not remove the protective caps from the fiber cables or the SFP modules to ensure the connections stay clean.

Perform the following steps to install SFP or SFP+ module in a slot:

1. Remove the dust cover from the transceiver.

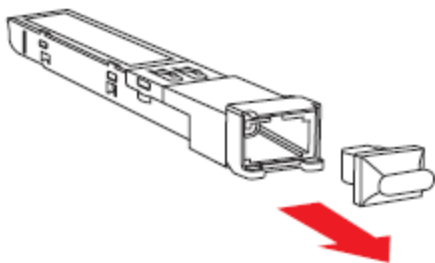

2. For transceivers with a flip-up or flip-down latch, close the latch.
3. Insert the fiber optic cable into the transceiver.

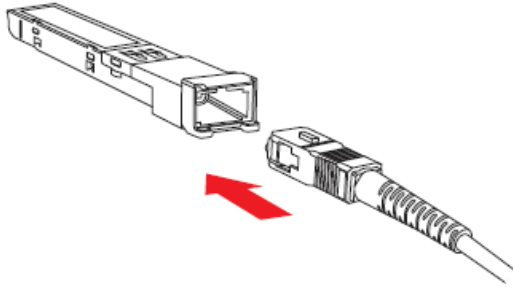

Note

You may need to remove a cable dust cover.

4. Insert the transceiver into the slot.

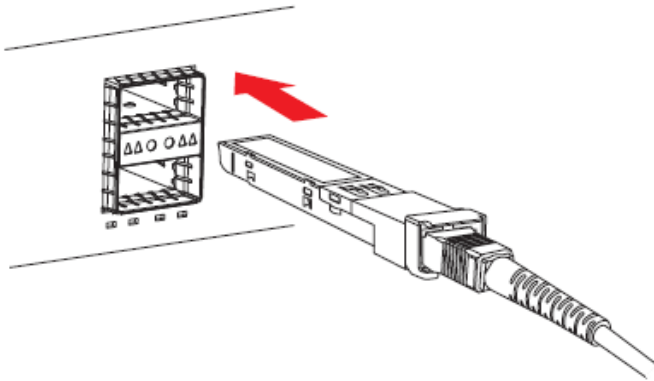

5. Press the transceiver firmly until it fits in its place.

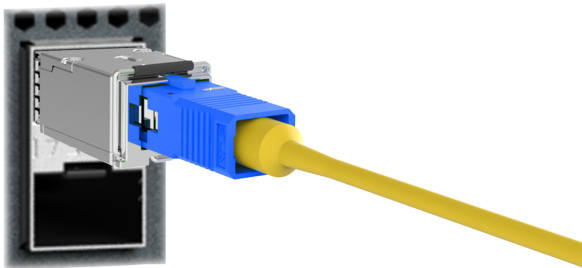

Removing a transceiver

Perform the following steps to remove an SFP or SFP+ from a slot:

1. Remove the fiber optic cable from the transceiver.

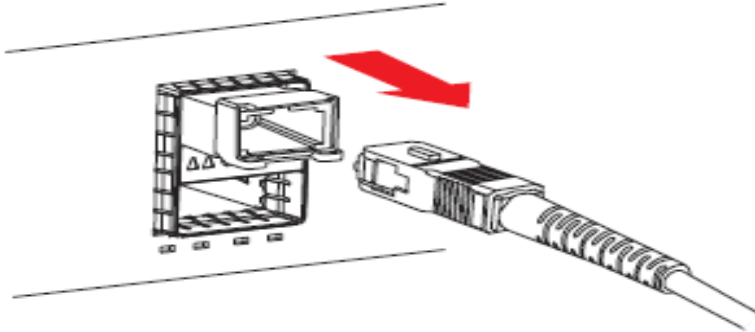

2. Unlock the transceiver latch.

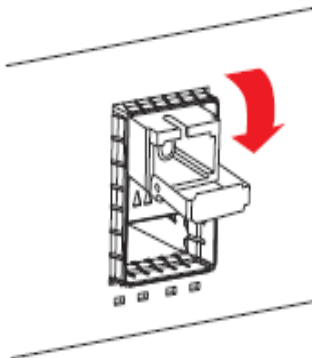

3. Pull the transceiver's out of the slot.

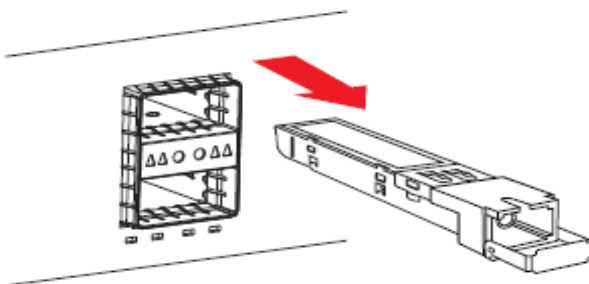

4. Put the transceiver dust cover on the transceiver.

Connecting a fiber optic cable

Perform the following steps to connect a fiber optic cable to an SFP module:

1. Clean the fiber optic cable connector before inserting it into the SFP module.
2. Insert the fiber optic cable into the SFP module. Ensure that the latch on the cable faces the top of the SFP module.
3. Slide the cable into slot until it is connected, and an audible sound is heard.



Disconnecting a fiber optic cable

To disconnect the fiber optic cable, depress the transceiver handle to release the latch on the cable and pull the cable out of the port, simultaneously.

Installing the ONTs

This section explains the installation procedures of ONTs hardware appliance using available mounting options. ONT is shipped with an accessory kit that includes the equipment required to install the ONTs.

This topic contains the following sections:

- [Installing the indoor ONT](#)
- [Installing the outdoor ONT](#)

Installing the indoor ONT

Perform the following steps to install the indoor ONT:

1. Connect internet to the PON port.
2. Connect PC to the LAN port.
3. Connect power socket to the power port.

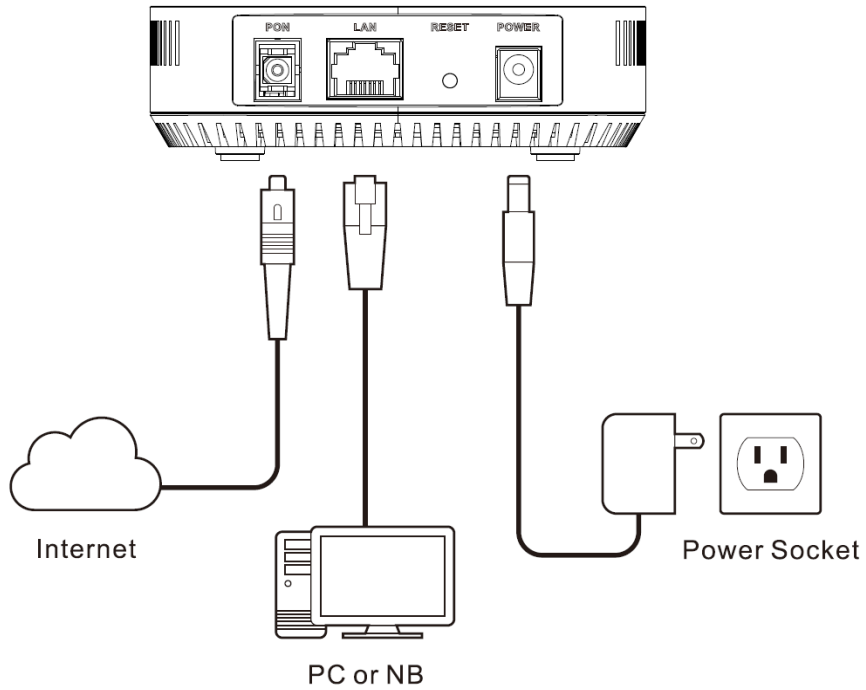

Wall mounting

Perform the following steps to mount the indoor ONT on the wall:

1. Make two holes on the wall. The gap between the holes must be 76.6 mm.
2. Insert the PE 6.5 x 35 anchors.
3. Insert the M4 x 32 mm screws into the anchors.

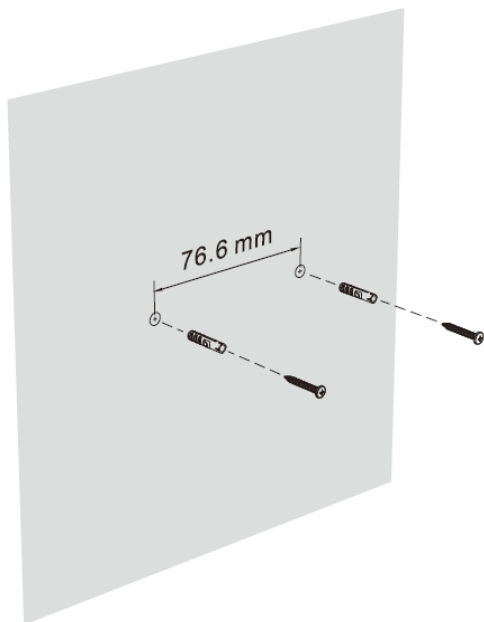

4. Hang the ONT on the wall.

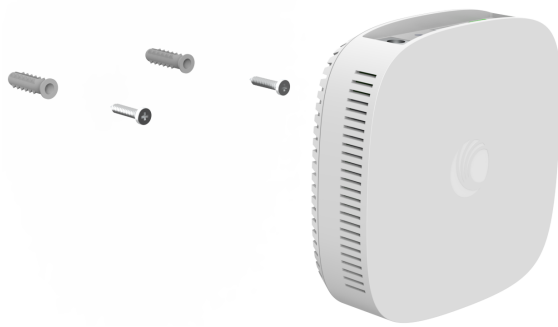

Installing the outdoor ONT



Attention

1. Skilled personnel are required to install the outdoor ONT.
2. The equipment should be installed in locations that are not accessible by children.
3. This product is intended to be supplied by a PoE power supply or DC power source marked with **L.P.S. (Limited Power Source)**, rated 30 Vdc, 0.5 A minimum, T_{ma} = 50°C minimum, and altitude 3000 m minimum.
4. The mains power cord of the adapter should be connected to a socket-outlet with an earthing connection.

Perform the following steps to install outdoor ONT:

1. Mount the device on a wall with three M4 x 32 mm screws.



- Slide off the cover and hold it with the main body by a lock.

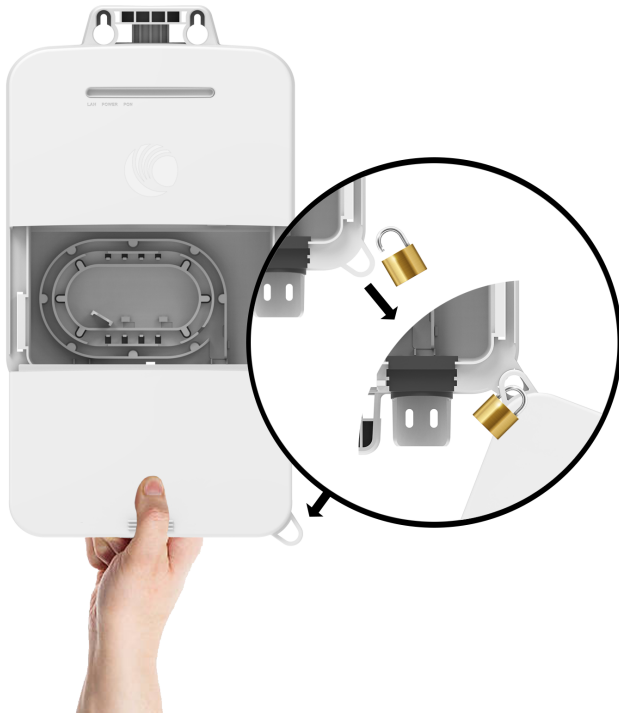

- Pull up the rubber grommet and cut it with a utility knife.

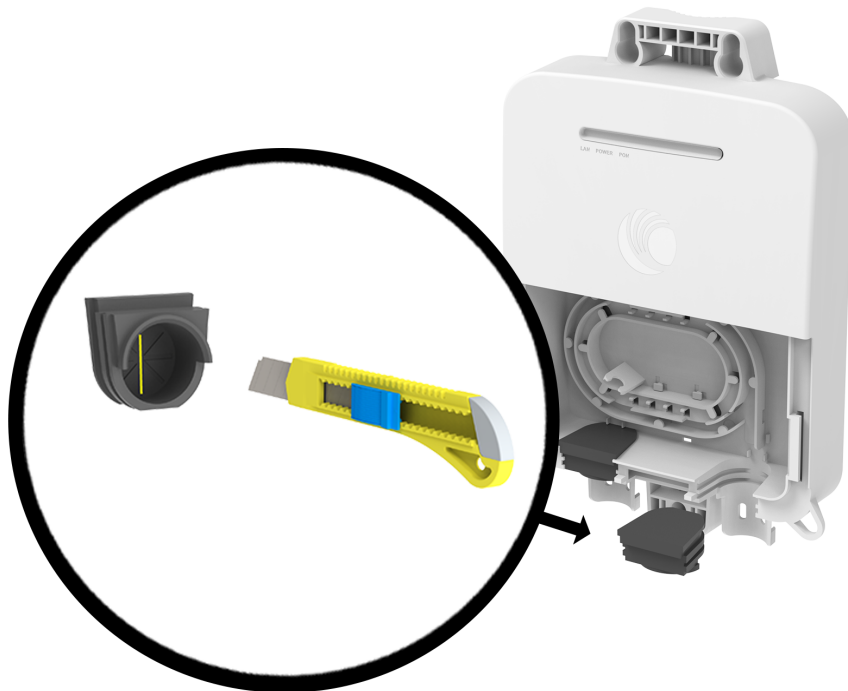

4. Insert the optical fiber cable into a water pipe and rubber grommet, and fix the water pipe to the main body with a hose clamp.



5. Wind the optical fiber cable to the fiber spool, and fix it to the spool with a cable. Then, plug the cable into the PON port.

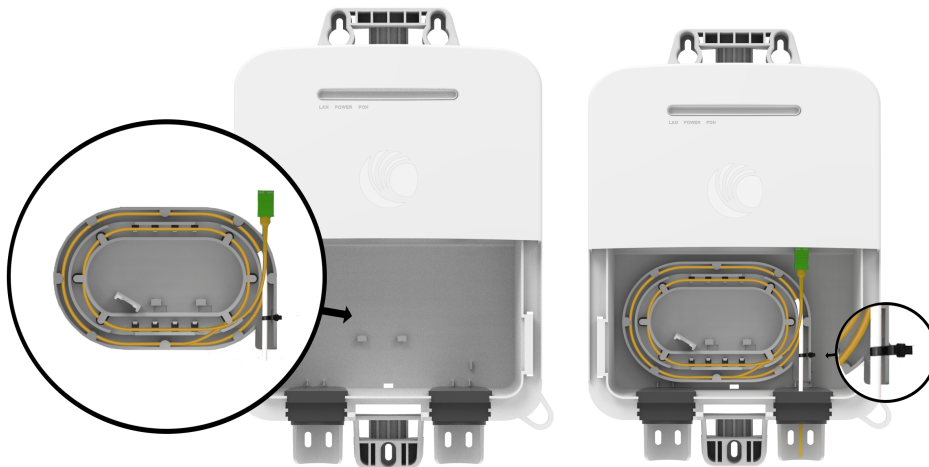

6. Plug in the Ethernet cable to LAN port through the rubber grommet, and fix the cable to the main body with a cable tie.

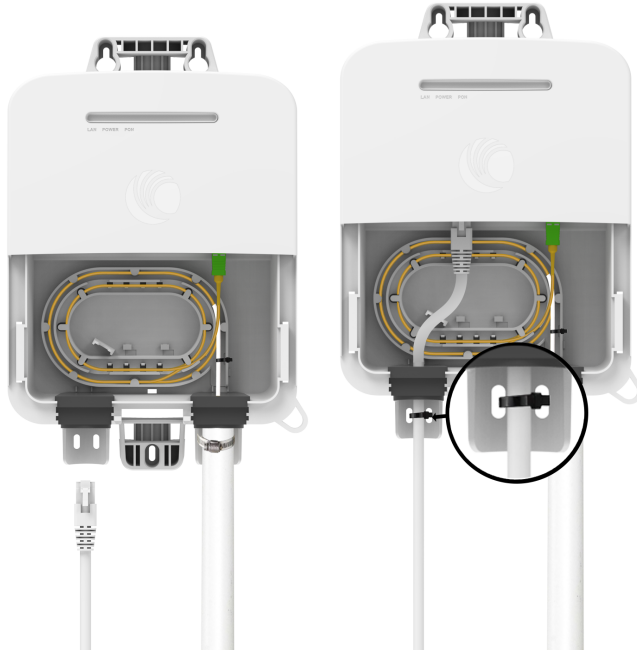

7. Place the PoE at home, and connect it through the RJ45 cable.
8. Close the cover and use a lock to lock it. Use the cable tie on the sliding door to lock the ONT.

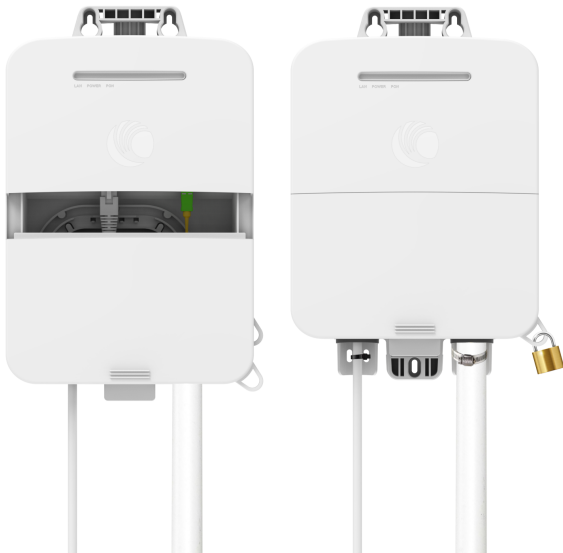

User Interface (UI) Configuration

This topic explains how to configure the UI of OLT and ONT.

This topic contains the following sections:

- [OLT UI configuration](#)
- [ONT UI configuration](#)

OLT UI configuration

This topic explains how to set up the management PC and configure OLT using the UI. For more information on UI configuration and software upgrade, refer to *OLT and ONT User Guide*.

This topic contains the following sections:

- [Configuring the management PC](#)
- [Logging in to OLT UI](#)
- [Configuring the OLT management IP address](#)
- [Software upgrade](#)
- [Zero touch provisioning](#)
- [Manual onboarding](#)
- [Mapping PON port to NNI port](#)

Configuring the management PC

You must configure the PC (for example, using Windows PC) or laptop to set up the IP address (169.254.1.100) with a subnet mask of 255.255.0.0 to access the Cambium OLT on the link local address of 169.254.1.1. This configuration enables the PC to communicate with the OLT and ONTs.

To configure the management PC, perform the following steps:

1. On Windows PC, click **Start > Settings > Network & Internet**.

The **Network Status** page appears with multiple options on the left navigation column.

2. Select **Ethernet > Change adapter settings**.

The **Network Connections** page appears.

3. Select **Ethernet** and right-click to select **Properties**.

The **Ethernet Properties** dialog box appears with the **Networking** and **Sharing** tabs, as shown in [Figure 7](#).

Figure 7: The Ethernet Properties dialog box

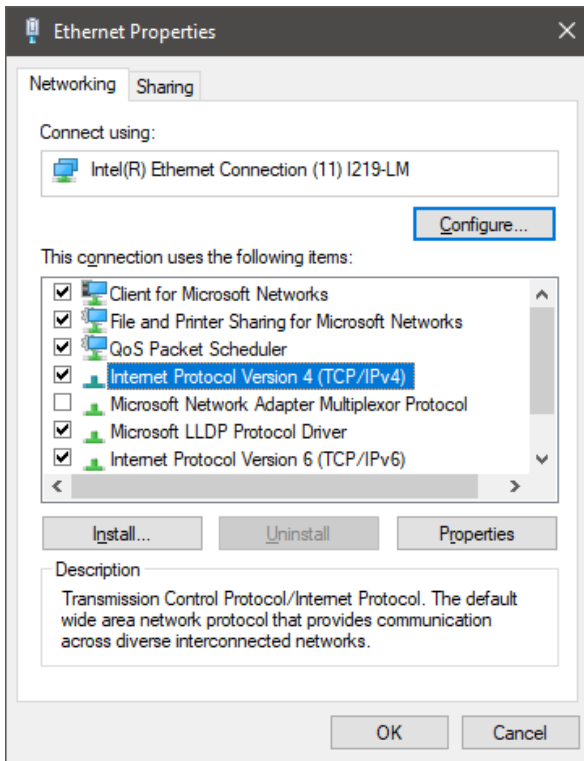

By default, the **Networking** tab is selected.

4. Select **Internet Protocol Version 4 (TCP/IPv4)** from the available list of connections (as shown in [Figure 7](#)).
5. Click **Properties**.

The **Internet Protocol Version 4 (TCP/IPv4) Properties** dialog box appears, as shown in [Figure 8](#).

6. In the **Use the following IP address** section, type an appropriate IP address in the IP address text box as 169.254.1.X and a subnet mask as 255.255.0.0, avoiding 169.254.1.1. Example: 169.254.1.100.

Figure 8: The Internet Protocol Version 4 Properties dialog box

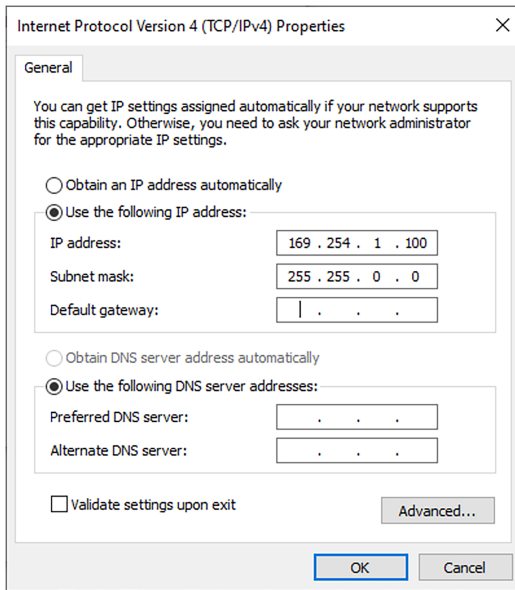

7. Leave the **Default gateway** text box blank and click **OK**.
8. Connect the PC to OLT management interface with an Ethernet cable, as shown in Figure 9.

Figure 9: PC connection with OLT

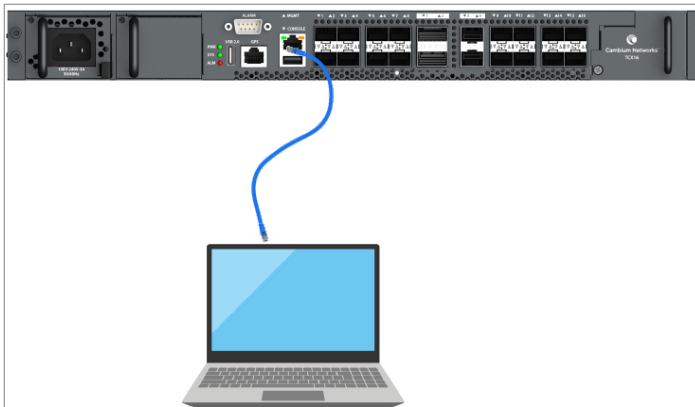

9. Ping *169.254.1.1* to confirm connectivity or open a browser and navigate to *169.254.1.1*, and verify the OLT IP is connected.

Logging in to OLT UI

To log in to OLT UI, perform the following steps:

1. Open a browser and type <http://169.254.1.1/>.

The login page appears, as shown in Figure 10.

Figure 10: The login page - OLT

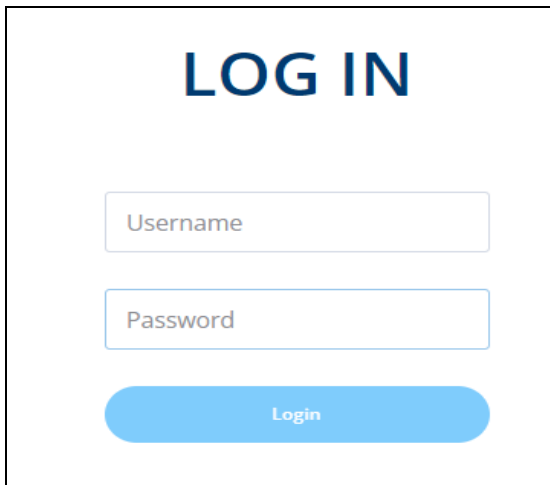

2. Log in to the OLT UI using the following credentials:
Username: **admin**
Password: **admin**
3. Click **Login**.
4. When you log in for the first time, the **Please change Default Administrator password** window appears.
5. Enter a new password in the **Administrator Password**.
6. Confirm the password in the **Confirm Password**.
The Status page appears, as shown in [Figure 11](#).

Figure 11: The Status page

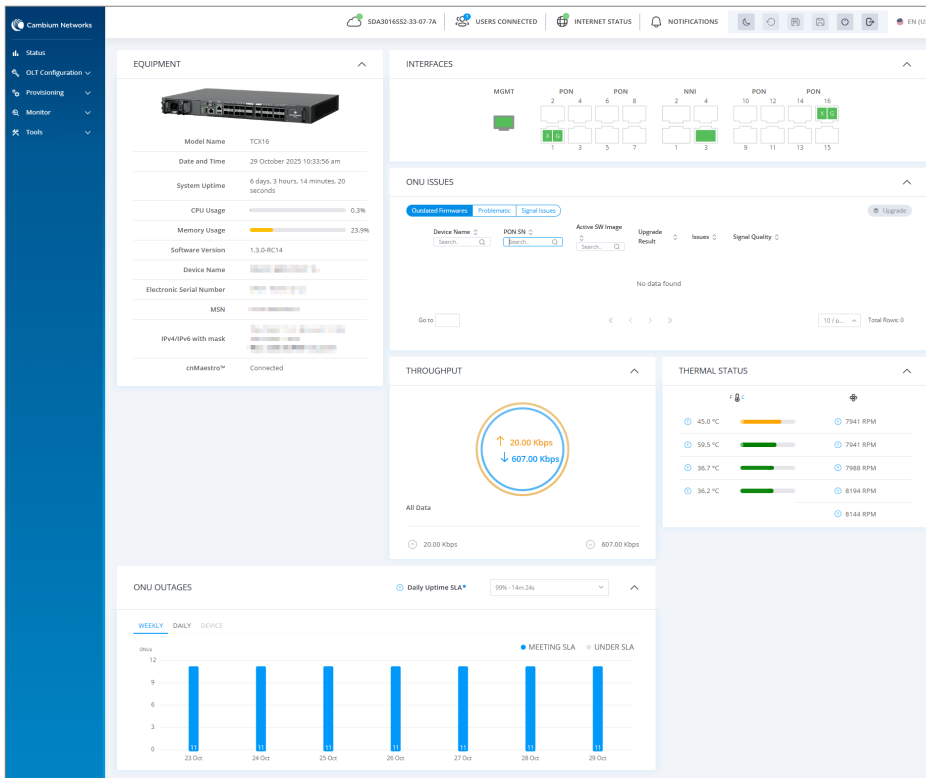

Table 4 lists and describes the components in the dashboard page.

Table 4: The dashboard page components

Elements	Descriptions
Equipment	
Model Name	Displays the model name of the device.
Date and Time	Current system date and time.
System Uptime	Uptime of the system.
CPU Usage	CPU utilization percentage.
Memory Usage	Memory utilization percentage.
Software Version	Current software version.
Device Name	OLT device name.
Electronic Serial Number	OLT MAC address.
MSN	OLT serial number.

Elements	Descriptions
IPv4/IPv6 with mask	Display the OLT IPv4/IPv6 with mask support, enabling configuration and management of devices using IPv6 addresses.
cnMaestro	cnMaestro connection status.
Throughput	Displays the total DL and UL PON throughput. The DL throughput is displayed by a downward arrow and the UL throughput is displayed by an upward arrow.
Interfaces	
Ports	<p>ONTs connect using transceivers as follows:</p> <ul style="list-style-type: none"> • MGMT Port - One dedicated 100/1000Base-T RJ45 Ethernet port for out-of-band management, labeled MGMT. • PON Ports - Eight SFP+ ports (1–8), each supporting GPON, XGS-PON, or Combo PON transceivers. • NNI Ports - Two QSFP28 ports (1, 3) and two SFP28 ports (2, 4) for uplinks; support 1G–100G Ethernet, breakout, and FEC. • PON Ports (TCX16 only) - Additional eight SFP+ ports (9–16) on TCX16 models, also supporting GPON, XGS-PON, or Combo PON transceivers.
Thermal Status	
Compute Module Temperature	<p>Displays the Compute Module Temperature such as:</p> <ul style="list-style-type: none"> • Switch Chip Temperature • Board Left Temperature • Board Right Temperature
Chassis Fan	Displays the fan speed in RPM for each of the five fans located in the replaceable fan module.
ONU Outages	
Online/Offline	<p>Displays ONU availability using two views:</p> <ul style="list-style-type: none"> • Weekly View: Displays the number of ONUs that fell below the selected SLA threshold on each day of the week. • Daily View: Provides per-ONU uptime and outage timelines for the selected day, detailing offline durations and status transitions.

Elements	Descriptions
	The Daily Uptime SLA selector defines the maximum allowable downtime per day (Example: 99.9% SLA = 1 minute 26 seconds). ONUs that exceed this downtime are classified as under SLA and counted in the daily outage metrics.
ONU Issues	The ONU Issues section displays with the following indicators: <ul style="list-style-type: none"> • Outdated Firmware – Displays ONUs running software versions older than the OLT firmware. • Problematic – Lists ONUs with onboarding issues such as frequent reconnection attempts. • Signal Issues – Lists ONUs operating outside of the recommended operating range.

OLT Software upgrade

Before upgrading the software, log in to the ONT UI, refer to [Logging in to OLT UI](#).

The Software Upgrade page is used to upgrade the OLT firmware. To upgrade the OLT software, perform the following steps:

1. From the dashboard page, navigate to **Tools > Software Upgrade**.

The **OLT Software Update** page appears, as shown in [Figure 12](#).

Figure 12: The Software Upgrade page

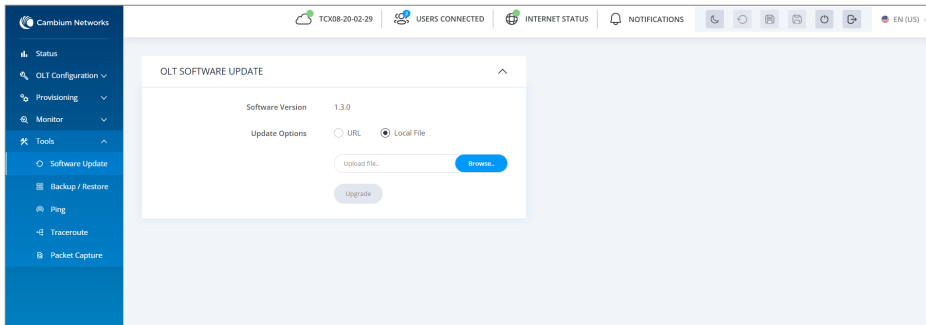

2. If you are upgrading the software using the URL, then select the **URL** option as the value of the **Update Options** parameter in the OLT Software Upgrade section. Then, type the URL of the location where you want to download the software.
3. If you are upgrading the software using the downloaded software image file, then select the **Local** option. Browse the folder and select the upgrade software image file.

To ensure the integrity of the OLT software image file, User can verify the MD5 and SHA256 checksums provided by cambium networks.

After downloading the file from the support site, compare the generated checksum with the following values:

Algorithm	Hash
SHA256	1839C89DCC333D9F3B1E0B399AEA8AA8D054B3620518987443445BA2CBEB28D4
MD5	7E679544EAA646E48438EFD4FBD7EAE4

If the checksums match, the file is confirmed to be corruption-free.

4. Click **Upgrade** to start the upgrade process.
5. After upgrading the OLT software, reboot OLT.

For more information on UI configuration, refer to *OLT and ONT User Guide*.

Configuring the OLT management IP address

To configure the OLT management IP address, perform the following steps:

1. From the dashboard page, navigate to **Configuration > Network**.

The **Network** page appears, as shown in [Figure 13](#).

Figure 13: Configuring OLT management IP address

2. In the **General** section, select **Static** as the value for the **IP Assignment** parameter.
3. In the **IPv4/IPv6 with mask** text box, type IPv4/IPv6 address of OLT.

4. In the **Gateway** text box, type the gateway address of OLT.
5. In the **Gateway IPv6** text box, type the gateway IP address of OLT.
6. In the **DNSv4/DNSv6** text box, type the DNS IP address based on your network requirements.
7. Click **Save** () at the top-right corner.

You have now configured the management IP address for OLT.

Zero touch provisioning

OLT from Cambium Networks supports zero touch provisioning. The auto discover of ONUs option is available in OLT after it is connected to the PON ports using splitters and the optical cable. To view the discovered ONU list, navigate to **Monitor > ONU** from the dashboard page.

Figure 14 shows the ONU list and the serial numbers. You can note down the ONU serial number from this page and use them for whitelisting.

Figure 14: List of ONUs on the OLT UI page

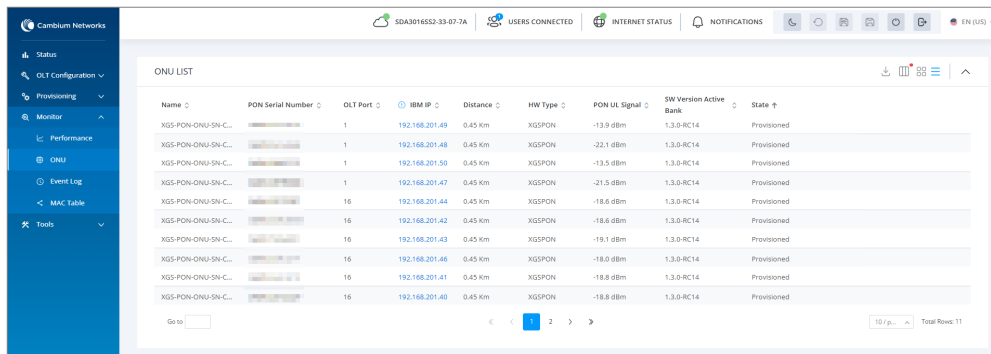

Name	PON Serial Number	OLT Port	IBM IP	Distance	HW Type	PON UL Signal	SW Version Active	State
XGS-PON-ONU-SN-C...		1	192.168.201.49	0.45 Km	XGSPON	-13.9 dBm	1.3.0-RC14	Provisioned
XGS-PON-ONU-SN-C...		1	192.168.201.48	0.45 Km	XGSPON	-22.1 dBm	1.3.0-RC14	Provisioned
XGS-PON-ONU-SN-C...		1	192.168.201.50	0.45 Km	XGSPON	-13.5 dBm	1.3.0-RC14	Provisioned
XGS-PON-ONU-SN-C...		1	192.168.201.47	0.45 Km	XGSPON	-21.5 dBm	1.3.0-RC14	Provisioned
XGS-PON-ONU-SN-C...		16	192.168.201.44	0.45 Km	XGSPON	-18.6 dBm	1.3.0-RC14	Provisioned
XGS-PON-ONU-SN-C...		16	192.168.201.42	0.45 Km	XGSPON	-18.6 dBm	1.3.0-RC14	Provisioned
XGS-PON-ONU-SN-C...		16	192.168.201.43	0.45 Km	XGSPON	-19.1 dBm	1.3.0-RC14	Provisioned
XGS-PON-ONU-SN-C...		16	192.168.201.46	0.45 Km	XGSPON	-18.0 dBm	1.3.0-RC14	Provisioned
XGS-PON-ONU-SN-C...		16	192.168.201.41	0.45 Km	XGSPON	-18.8 dBm	1.3.0-RC14	Provisioned
XGS-PON-ONU-SN-C...		16	192.168.201.40	0.45 Km	XGSPON	-18.8 dBm	1.3.0-RC14	Provisioned

By default, OLT is configured with **VLAN 100** for the **NNI3** port. The **ONT LAN 100** port supports **untagged** user traffic, as shown in Figure 15.



Figure 15: Untagged user traffic

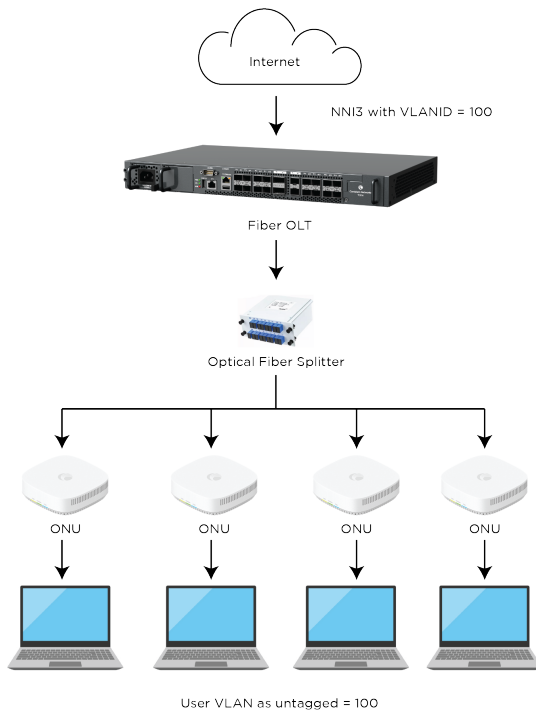

ONT UI configuration

This topic explains how to log in to the GPON and XGS-PON ONT UI and perform the required configurations. For more information, refer to *OLT and ONT User Guide*.

This topic contains the following sections:

- [Logging in to ONT UI](#)
- [Software upgrade](#)

Logging in to ONT UI

To configure the management PC before log in, refer to [Configuring the management PC](#).

To log in to ONT UI, perform the following steps:

1. Open a browser, and type <http://169.254.1.1/>.

The login page appears, as shown in [Figure 16](#).

Figure 16: The ONT login page

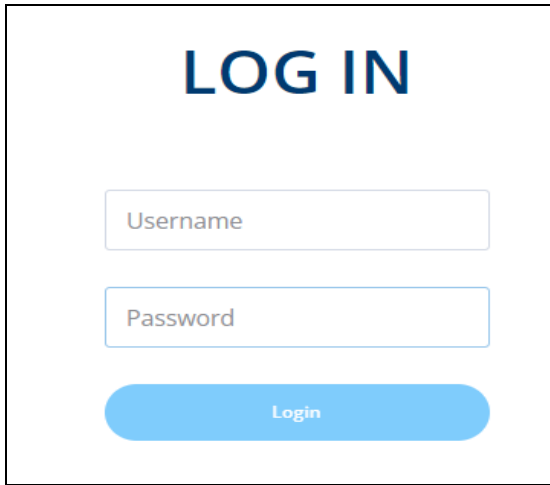

2. Log in to the ONT UI using the following credentials:

Username: **admin**

Password: **admin**

The dashboard page appears, as shown in [Figure 17](#).

Figure 17: The dashboard page - ONT UI

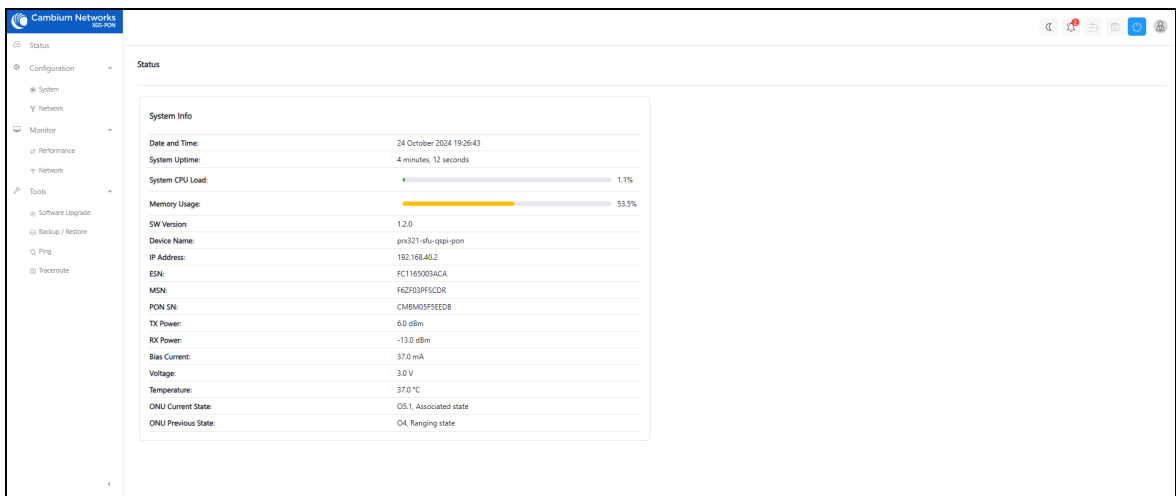

The dashboard page displays the system information of ONT. For more information on UI configuration and software upgrade, refer to *OLT and ONT User Guide*.

Software upgrade

Before upgrading the software, log in to the ONT UI, refer to [Logging in to ONT UI](#).

To upgrade the ONT software, perform the following steps:

1. From the dashboard page of ONT, navigate to **Tools > Software Upgrade**.

The **Software Upgrade** page appears, as shows in [Figure 18](#).

Figure 18: The Software Upgrade page

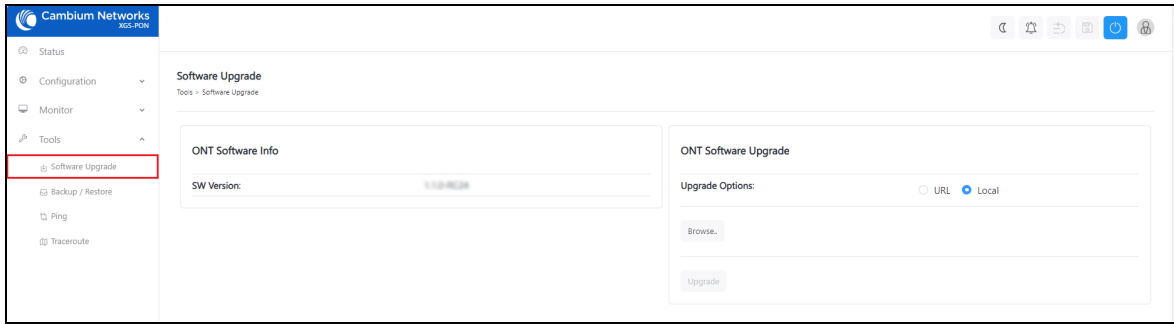

The **ONT Software Info** section displays the current software version of ONT.

2. If you are upgrading the software using the URL, then select the **URL** option as the value of the **Update Options** parameter in the ONT Software Upgrade section. Then, type the URL of the location where you want to download the software.
3. If you are upgrading the software using the downloaded software image file, then select the **Local** option. Browse the folder and select the upgrade software image file.
4. Click **Upgrade** to start the upgrade process.
5. Click on the **Notifications** icon () to view the status of the upgrade process as shown in Figure 19.

Figure 19: Software upgrade notifications



6. After upgrading the ONT software, reboot ONT.

Pluggable ONU

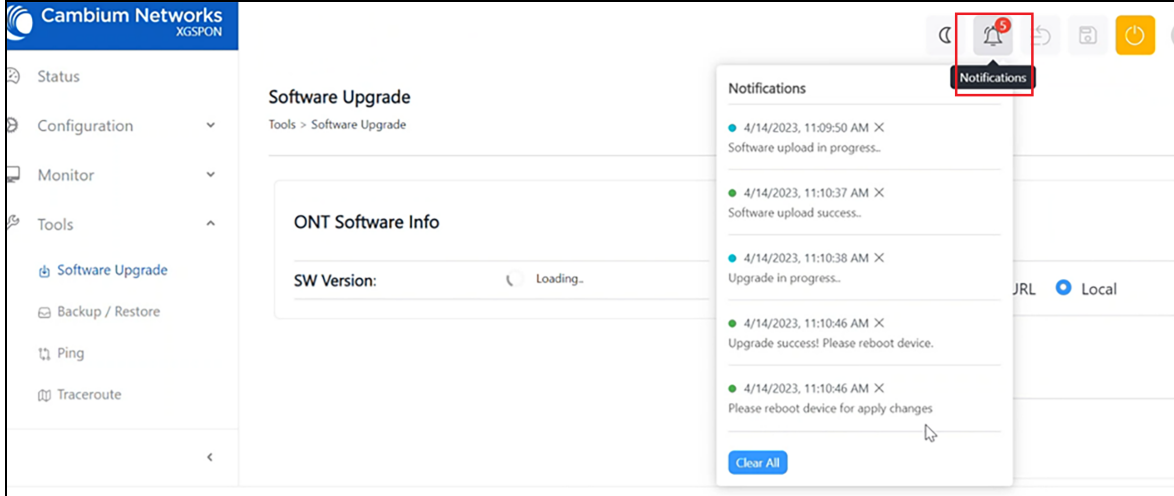
The Pluggable ONU (ONT Stick) is a compact ONU form factor that does not include an internal power source. It draws power directly from a host device such as a switch, access point (AP), ePMP AP, PMP AP, or cnWave device. Once inserted into a supported host device, the ONT stick powers on and becomes operational.



Note:

Ensure that the pluggable ONU is upgraded to software version 1.3.0 or later. If the device is not upgraded to version 1.3.0 or later, cnMaestro may display limited information or show only a single pluggable ONU even when multiple devices are connected.

Pluggable ONUs supports full VLAN functionality, including Any Tag, Q-in-Q Trunk, and other complex VLAN configurations, enabling broader compatibility and improved service.

Software Update

The Software Update tab allows users to upload and apply firmware updates for GPON, XGS-PON ONTs, and Pluggable ONUs. Firmware updates enhance functionality and provide necessary bug fixes.

To update the device software, perform the following steps:

1. Navigate to **Provisioning > Devices > SW Update**.

Figure 20: SW Update tab

Info	Device Name	PON SN	State	Model Name	Model Description	Active SW Image	ONU Type	PON Number	Action Result	Management
	XGS-PON-ONU-SH-CMBAS...		Provisioned	50000	Indoor ONT XGS-PON	1.3.0-RC22	XGSPON	1	--	192.168.201
	XGS-PON-ONU-SH-CMBAS...		Provisioned	50000	Indoor ONT XGS-PON	1.3.0-RC22	XGSPON	1	--	192.168.201
	XGS-PON-ONU-SH-CMBAS...		Provisioned	50000	Indoor ONT XGS-PON	1.3.0-RC22	XGSPON	1	--	192.168.201
	XGS-PON-ONU-SH-CMBAS...		Provisioned	50000	Indoor ONT XGS-PON	1.3.0-RC22	XGSPON	16	--	192.168.201
	XGS-PON-ONU-SH-CMBAS...		Provisioned	50000	Indoor ONT XGS-PON	1.3.0-RC22	XGSPON	16	--	192.168.201
	XGS-PON-ONU-SH-CMBAS...		Provisioned	50000	Indoor ONT XGS-PON	1.3.0-RC22	XGSPON	16	--	192.168.201
	XGS-PON-ONU-SH-CMBAS...		Provisioned	50000	Indoor ONT XGS-PON	1.3.0-RC22	XGSPON	16	--	192.168.201
	XGS-PON-ONU-SH-CMBAS...		Provisioned	50000	Indoor ONT XGS-PON	1.3.0-RC22	XGSPON	16	--	192.168.201
	XGS-PON-ONU-SH-CMBAS...		Provisioned	50000	Indoor ONT XGS-PON	1.3.0-RC22	XGSPON	16	--	192.168.201

2. Select the required pluggable ONU device from the list.
3. **Choose the Firmware for Update** from the drop-down.
Example: Cambium-Fiber-XGSPON-ST-ONT-v1.3.0.img
4. Click **Upgrade**.

Cambium Networks

Cambium Networks delivers wireless communications that work for businesses, communities, and cities worldwide. Millions of our radios are deployed to connect people, places and things with a unified wireless fabric that spans multiple standards and frequencies of fixed wireless and Wi-Fi, all managed centrally via the cloud. Our multi-gigabit wireless fabric offers a compelling value proposition over traditional fiber and alternative wireless solutions. We work with our Cambium certified ConnectedPartners to deliver purpose-built networks for service provider, enterprise, industrial, and government connectivity solutions in urban, suburban, and rural environments, with wireless that just works.

User Guides	http://www.cambiumnetworks.com/guides
Technical training	https://learning.cambiumnetworks.com/learn
Support website (enquiries)	https://support.cambiumnetworks.com
Main website	http://www.cambiumnetworks.com
Sales enquiries	solutions@cambiumnetworks.com
Warranty	https://www.cambiumnetworks.com/support/standard-warranty/
Telephone number list	http://www.cambiumnetworks.com/contact-us/
Address	Cambium Networks Limited, Unit B2, Linhay Business Park, Eastern Road, Ashburton, Devon, TQ13 7UP United Kingdom



Cambium Networks and the stylized circular logo are trademarks of Cambium Networks, Ltd. All other trademarks are the property of their respective owners.

© Copyright 2026 Cambium Networks, Ltd. All rights reserved.